

YUTAKI SERIES

Technical Catalogue

Split system - Outdoor unit
RAS-(2-10)WH(V)NP(E)

Split system - Indoor unit

YUTAKI S

RWM-(2.0-10.0)NE

YUTAKI SCombi

RWD-(2.0-6.0)NW(S)E-(200/260)S(-K)

YUTAKI S80

RWH-(4.0-6.0)(V)NF(W)E

YUTAKI S80 TANK

DHWS(200/260)S-2.7H2E

Monobloc system

YUTAKI M

RASM-(3-6)(V)NE



Contents

General information	1
Features and benefits	2
General data	3
Capacity and selection data	4
Acoustic characteristic curves	5
Working range	6
General dimensions	7
Refrigerant cycle and hydraulic circuit	8
Refrigerant and water piping	9
Electrical and control settings	10
Optional functions	11

General Index

1.	General information.....	1
1.1	General information.....	2
1.1.1	General notes.....	2
1.1.2	Introduction.....	2
1.1.2.1	Overview of YUTAKI system.....	2
1.1.2.2	Summary of operations.....	3
1.2	Applied symbols.....	5
1.3	Product guide.....	6
1.3.1	Classification of the units.....	6
1.3.1.1	Split system - Outdoor unit.....	6
1.3.1.2	Split system - Indoor unit.....	6
1.3.1.3	Monobloc system.....	7
1.3.2	Product guide.....	8
1.3.2.1	Split system - Outdoor unit.....	8
1.3.2.2	Split system - Indoor unit.....	8
1.3.2.3	Monobloc system.....	11
1.3.3	Accessory code list.....	12
2.	Features and benefits.....	15
2.1	Selection benefits.....	16
2.1.1	Wide selection range.....	16
2.1.2	High efficiency system. Wide capacity range.....	19
2.1.3	Wide range of accessories and components.....	19
2.2	Installation benefits.....	26
2.2.1	YUTAKI S reduced dimensions.....	26
2.2.2	YUTAKI S80 improved connections.....	27
2.3	Maintenance benefits.....	28
2.3.1	Filter + for the water circuit.....	28
2.3.2	New manual air purger for YUTAKI S COMBI.....	28
2.4	Control features.....	29
2.4.1	Unit controller: more functions.....	29
2.4.2	I/O and sensor functions.....	29
3.	General data.....	31
3.1	Capacity tables.....	32
3.1.1	Nominal capacity-performance tables.....	32
3.1.1.1	Considerations.....	32
3.1.1.2	Capacity-performance data.....	32

3.2	ERP performance data.....	35
3.2.1	General considerations	35
3.2.2	General ERP data for space heaters	35
3.2.2.1	ERP data - YUTAKI S.....	35
3.2.2.2	ERP data - YUTAKI S COMBI.....	41
3.2.2.3	ERP data - YUTAKI S80.....	46
3.2.2.4	ERP data - YUTAKI M.....	49
3.2.2.5	ERP additional data - YUTAKI S.....	52
3.2.2.6	ERP additional data - YUTAKI S COMBI	53
3.2.2.7	ERP additional data - YUTAKI S80	54
3.2.3	General ERP data for combi heaters (YUTAKI S COMBI & S80)	55
3.2.3.1	YUTAKI S COMBI	55
3.2.3.2	YUTAKI S80	56
3.2.4	General ERP data for hot water storage tanks (YUTAKI S , YUTAKI M & YUTAKI S 80 RWH-4.0VNFE.....	56
3.3	General specifications.....	57
3.3.1	Considerations	57
3.3.2	Split system - Outdoor unit.....	58
3.3.3	Split system - Indoor unit.....	60
3.3.3.1	YUTAKI S	60
3.3.3.2	YUTAKI S COMBI	63
3.3.3.3	YUTAKI S80	69
3.3.4	Monobloc system - YUTAKI M.....	72
3.3.5	Domestic Hot Water Tank.....	74
3.4	Component data.....	75
3.4.1	Split system - Outdoor unit.....	75
3.4.2	Split system - Indoor unit.....	77
3.4.2.1	YUTAKI S	77
3.4.2.2	YUTAKI S COMBI	78
3.4.2.3	YUTAKI S80	82
3.4.3	Monobloc system - YUTAKI M.....	83
3.5	Electrical data.....	85
3.5.1	Considerations	85
3.5.2	Split system - Outdoor unit.....	86
3.5.3	Split system - Indoor unit.....	87
3.5.3.1	YUTAKI S	87
3.5.3.2	YUTAKI S COMBI	87
3.5.3.3	YUTAKI S80	88
3.5.4	Monobloc system - YUTAKI M.....	90
4.	Capacity and selection data.....	91
4.1	System selection procedure.....	92
4.1.1	Selection parameters	92

4.1.2	Selection procedure	92
4.1.2.1	Description of procedure for YUTAKI S.....	94
4.1.2.2	Description of procedure for YUTAKI S COMBI.....	100
4.1.2.3	Description of procedure for YUTAKI S 80.....	107
4.1.2.4	Selection procedure for YUTAKI M units.....	114
4.1.3	Flow rate and pressure drop check.....	119
4.2	System selection procedure (by Selection Software).....	120
4.2.1	Introduction.....	120
4.2.2	How to use the Selection Software	120
4.3	YUTAKI S	139
4.3.1	Maximum heating capacity table (kW) (Integrated).....	139
4.3.2	Maximum cooling capacity table (kW).....	141
4.4	YUTAKI S COMBI	142
4.4.1	Maximum heating capacity table (kW) (Integrated).....	142
4.4.2	Maximum cooling capacity table (kW)	144
4.5	YUTAKI S 80	145
4.5.1	Maximum heating capacity table (kW) (Integrated).....	145
4.6	YUTAKI M.....	146
4.6.1	Maximum heating capacity table (kW) (Integrated).....	146
4.6.2	Maximum cooling capacity table (kW)	147
4.7	Correction factors.....	148
4.7.1	Piping length correction factor.....	148
4.7.2	Correction factor owing to use of glycol (only for YUTAKI M).....	151
5.	Acoustic characteristic curves.....	153
5.1	Considerations	154
5.2	Sound pressure level for outdoor unit	155
6.	Working range.....	157
6.1	Power supply working range	158
6.2	Temperature working range.....	158
6.2.1	Space heating	158
6.2.2	DHW.....	160
6.2.3	Swimming pool heating	161
6.2.4	Space cooling (Necessary cooling kit)	161
6.3	Hydraulic working range.....	162
6.3.1	Hydraulic data	162
6.3.2	Pump performance curves	163

7.	General dimensions.....	169
7.1	Name of parts and Dimensional data.....	170
7.1.1	Split system - Outdoor unit.....	170
7.1.2	Split system - Indoor unit.....	172
7.1.2.1	YUTAKI S.....	172
7.1.2.2	YUTAKI S COMBI.....	175
7.1.2.3	YUTAKI S80.....	180
7.1.3	Monobloc system - YUTAKI M.....	183
7.2	Service space.....	185
7.2.1	Split system - Outdoor unit.....	185
7.2.2	Split system - Indoor unit.....	186
7.2.2.1	YUTAKI S.....	186
7.2.2.2	YUTAKI S COMBI.....	186
7.2.3	Monobloc system - YUTAKI M.....	190
8.	Refrigerant cycle and hydraulic circuit.....	191
8.1	Refrigerant cycle and hydraulic circuit for Split system.....	192
8.1.1	YUTAKI S.....	192
8.1.2	YUTAKI S COMBI.....	195
8.1.3	YUTAKI S80.....	197
8.1.3.1	Indoor unit standalone version.....	197
8.1.3.2	Indoor unit for integrated tank version.....	198
8.2	Refrigerant cycle and hydraulic circuit for Monobloc system - YUTAKI M.....	199
9.	Refrigerant and water piping.....	201
9.1	General notes before performing piping work.....	202
9.1.1	Piping work.....	202
9.1.2	Suspension of refrigerant and water pipes.....	202
9.2	Refrigerant circuit.....	203
9.2.1	Refrigerant piping.....	203
9.2.2	Refrigerant charge.....	204
9.2.2.1	Refrigerant charge amount.....	204
9.2.2.2	Refrigerant charge before shipment (W_0 (kg)).....	204
9.2.3	Precautions in the event of gas refrigerant leaks.....	205
9.3	Space heating and DHW.....	207
9.3.1	Additional hydraulic necessary elements for space heating.....	207
9.3.2	Additional hydraulic necessary elements for DHW.....	207
9.3.3	Additional hydraulic optional elements (For DHW).....	210
9.3.5	Requirements and recommendations for the hydraulic circuit.....	210
9.3.6	Water piping.....	212
9.3.7	Water quality (Preliminary information).....	215

10. Electrical and control settings.....	217
10.1 General check	218
10.2 System wiring diagram	221
10.3 Electrical connection	222
10.3.1 Wiring size.....	222
10.3.2 Minimum requirements of the protection devices.....	225
10.4 Transmission wiring between outdoor and indoor unit	227
10.5 Optional indoor unit wiring (accessories)	228
10.6 Setting of DIP switches and RSW switches	230
10.6.1 Outdoor unit.....	230
10.6.1.1 Location of DIP switches and rotary switches.....	230
10.6.1.2 Function of DIP switches and rotary switches.....	231
10.6.1.3 LED indication	232
10.6.2 YUTAKI unit.....	233
10.6.2.1 Location of DIP switches and rotary switches.....	233
10.6.2.2 Function of DIP switches and rotary switches.....	233
10.6.2.3 LED indication	236
11. Optional functions	237
11.1 Indoor unit	238
11.1.1 Optional functions from unit controller	238
11.1.2 Optional functions from DIP-switch setting.....	239
11.1.3 Optional external input/output signals (by 7-segment display).....	241
11.2 Additional functions by accessory sensor	242
11.3 Change of defrost condition	243
11.4 Optional external output signals for outdoor units and YUTAKI M units.....	244

1 . General information

Index

1.1	General information.....	2
1.1.1	General notes.....	2
1.1.2	Introduction	2
1.1.2.1	Overview of YUTAKI system.....	2
1.1.2.2	Summary of operations.....	3
1.2	Applied symbols	5
1.3	Product guide	6
1.3.1	Classification of the units.....	6
1.3.1.1	Split system - Outdoor unit	6
1.3.1.2	Split system - Indoor unit	6
1.3.1.3	Monobloc system.....	7
1.3.2	Product guide	8
1.3.2.1	Split system - Outdoor unit	8
1.3.2.2	Split system - Indoor unit	8
1.3.2.3	Monobloc system.....	11
1.3.3	Accessory code list.....	12



1.1 General information

1.1.1 General notes

© Copyright 2016 HITACHI Air Conditioning Products Europe, S.A.U. – All rights reserved.

No part of this publication may be reproduced, copied, filed or transmitted in any shape or form without the permission of HITACHI Air Conditioning Products Europe, S.A.U.

Within the policy of continuous improvement of its products, HITACHI Air Conditioning Products Europe, S.A.U. reserves the right to make changes at any time without prior notification and without being compelled to introducing them into previously sold products. This document may therefore have been subject to amendments during the life of the product.

HITACHI makes every effort to offer correct, up-to-date documentation. Despite this, printing errors cannot be controlled by HITACHI and are not its responsibility.

As a result, some of the images or data used to illustrate this document may not refer to specific models. No claims will be accepted based on the data, illustrations and descriptions included in this manual.

No type of modification must be made to the equipment without prior, written authorization from the manufacturer.



NOTE

This air conditioner has been designed for standard air conditioning for human beings. For use in other applications, please contact your HITACHI dealer or service contractor.

1.1.2 Introduction

HITACHI proudly announces the newest complete range of air-to-water heat pumps in its award-winning YUTAKI range.

YUTAKI units produce heating and domestic hot water like any oil or gas boiler, but transforming renewable energy from the outside air into heat. Air to water heat pumps extract the free energy present in the air, which is enough to heat a home up to a comfortable temperature, even on the coldest winter day. Every kW of electricity used to power the heat pump can yield up to more than 5 kW of energy for heating; this provides savings of up to 80% on heating expenses compared to a traditional fossil fuel boiler.

The new YUTAKI series, based on state-of-the-art technology, does not only achieve an outstanding performance in space heating, but it is also provides domestic hot water with high efficiency. Additionally, cooling operation for summer can also be provided installing the dedicated “Cooling kit” accessory of HITACHI.

The system is simple to control; its new user controller (PC-ARFHE) improves the acclaimed and successful design used with the existing LCD controller, and provides a great deal of new functions like: wizard start-up configuration, auto cool/heat, improved timer, etc.

1.1.2.1 Overview of YUTAKI system

The wide range of YUTAKI products is basically divided in two types of system:

- Split system
 - Monobloc system
- ◆ Split system - YUTAKI S, YUTAKI S COMBI, YUTAKI S80

It consists of one outdoor unit and one indoor unit. The outdoor unit extracts the heat present in the air, increases its refrigerant temperature and transmits it to the water circuit using the plate heat exchanger of the indoor unit, where the heat is taken to radiators (fan-coils), underfloor heating components or both (2nd temperature area).

Three types of indoor unit can be used in heating split systems:

YUTAKI S

The indoor unit of YUTAKI S is designed for space heating, in wall-mounted installation. It is convenient for new installations with low capacity requirements (Well isolated installations, high efficiency radiators...).

YUTAKI S COMBI

The indoor unit of YUTAKI S COMBI is conceived as a floor standing unit. It is prepared for heating operation as well as for domestic hot water production. For this purpose, it has a built-in domestic hot water tank available in two sizes (200 or 260 L). In line with YUTAKI S units, it meets the needs of installations with low capacity requirements.

Furthermore, special YUTAKI S COMBI models have been designed with a specific solar tank for the use of solar panels. Also, new models for the UK market that meet the UK requirements referred in the UK Building Regulations.

YUTAKI S80

The YUTAKI S80 is a standalone indoor unit that generates hot water up to 80°C; the hottest water temperature in the domestic heating market using renewable energy.

The extra innovation in the YUTAKI S80 lies in that it has two compressors, working in a smart cascade system, with two refrigerant cycles (R-410A and R-134a). To maximize seasonal efficiency, the second refrigerant cycle is only operated as a booster, when very high water temperature is required - the rest of the time, only one cycle is used.

The YUTAKI S80 is ideal for existing properties, in particular older installations where high water supply temperatures may be required to keep the house warm – as well as for new buildings. It is designed for the replacement of boilers, offering heating and sanitary hot water all year round, without boiler back-up.

Two different models have been designed for different purposes: one model for space heating only and the other one for space heating as well as for DHW operation. For DHW operation (optional), HITACHI offers two specific YUTAKI S80 DHW tanks (DHWS200S-2.7H2E and DHWS260S-2.7H2E) which may be placed on top of the indoor unit or besides it, as an integrated unit to provide high-temperature domestic hot water enjoying the benefits of the high efficiency of the heat pump.

◆ Monobloc system - YUTAKI M

YUTAKI M is a monobloc air to water heat pump system composed by only an special outdoor unit, which carries out the function of an air-to-water heat pump. This results in an excellent solution when installation space available is limited.

YUTAKI M is designed to be installed outdoors, in any kind of dwelling (house, apartment, villa,...), whether in a new construction or in an existing building. Installation work is greatly simplified thanks to the lack of refrigerant piping connections.

1.1.2.2 Summary of operations

Space heating

YUTAKI units are factory-supplied ready for space heating operation. Different heating installation configurations can be selected, providing a comfortable atmosphere all year long, even in the coldest climates:

- **Mono-valent system**

The air to water heat pump is sized to provide 100% of the heating requirements on the coldest day the year.

- **Mono-energy system**

This is the most popular configuration. The air to water heat pump is sized to provide 80% of the heating requirements on the coldest days of the year. An auxiliary electric heater is used to provide the additional heating required on cold days. This option usually results in an ideal balance between installation costs and future energy consumption, as proven by its popularity in colder climates than ours, such as Sweden and Norway.

- **Alternating Bi-valent system**

For installations with an existing heating system by boiler and when is needed to heat the supplied water temperature to the circuit up to high temperatures (80°C), the boiler can be configured to alternate with the air to water heat pump.

Selecting the different configuration types it is possible to adapt the system to all customer requirements, providing a wide application range from the simplest configuration to complete configuration: Radiator, heating floor or both (2nd temperature area).

Domestic hot water production

YUTAKI models also give the option of domestic hot water production, allowing the user to benefit from the heat pump's high efficiency and achieve domestic hot water.

This is made possible by a domestic hot water tank. In case of YUTAKI S COMBI, the domestic hot water tank is built in the indoor unit. In YUTAKI S80, a specific DHW tank is designed for combination with the indoor unit. For YUTAKI S and YUTAKI M, the HITACHI accessory "DHWT-(200/260)S-3.0H2E" can be used for the production of DHW.

An electric heater is incorporated inside the tank in order to allow an immediate heating of the domestic hot water in accordance with the user's needs.

Space cooling

YUTAKI units can also be operated in cooling operation. The dedicated "Cooling kit" accessory has been designed for this purpose. Combining the heating only models with these cooling kits, the reversible models become available. In this case, combination with fan-coils, refreshing floor or both (2nd temperature area) can be applied.

Combination with solar panels

YUTAKI system can be combined with solar panel. The solar combination enables to heat up the DHW by means of the sun. The solar combination is designed to transfer the heat from the solar panels (sun radiation) to the heat exchanger of DHW tank.

In case of YUTAKI S COMBI, a specific model with integrated tank for solar combination has been designed, as explained before.

Swimming pool water heating operation

For summer session period, YUTAKI system can be used to heat up the water temperature of swimming pools up to a value between 24 and 33°C.

1.2 Applied symbols

During normal air conditioning system design work or unit installation, greater attention must be paid in certain situations requiring particular care in order to avoid damage to the unit, the installation or the building or property.

Situations that pose a risk to the safety of those in the surrounding area or to the unit itself are clearly indicated in this manual.

A series of special symbols are used to clearly identify these situations.

Pay close attention to these symbols and to the messages following them, as your safety and that of others depends on it.



DANGER

- ***The text following this symbol contains information and instructions relating directly to your safety.***
- ***Not taking these instructions into account could lead to serious, very serious or even fatal injuries to you and others.***

In the texts following the danger symbol you can also find information on safety procedures during unit installation.



CAUTION

- *The text following this symbol contains information and instructions relating directly to your safety.*
- *Not taking these instructions into account could lead to minor injuries to you and others.*
- *Not taking these instructions into account could lead to unit damage.*

In the texts following the caution symbol you can also find information on safety procedures during unit installation.



NOTE

- *The text following this symbol contains information or instructions that may be of use or that require a more thorough explanation.*
- *Instructions regarding inspections to be made on unit parts or systems may also be included.*

1.3 Product guide

1.3.1 Classification of the units

1.3.1.1 Split system - Outdoor unit

Unit type: Outdoor unit (Split air system)									
Position-separating hyphen (fixed)									
Compressor power (HP): 2, 2.5, 3, 4, 5, 6, 8, 10.									
For water combination									
Heat pump									
V: Single phase unit (1~ 230V 50Hz) —: Three phase unit (3N~ 400V 50Hz)									
R410A refrigerant									
Premium series									
E: Made in Europe —: Made in Japan									
RAS	-	X	W	H	(V)	N	P	(E)	

1.3.1.2 Split system - Indoor unit

◆ YUTAKI S

Unit type: YUTAKI S (Split system - Single water module (Indoor unit) - Medium/Low temperature)					
Position-separating hyphen (fixed)					
Compressor power of the combined outdoor unit (HP): 2.0, 2.5, 3.0, 4.0, 5.0, 6.0, 8.0, 10.0.					
R410A refrigerant					
Made in Europe					
RWM	-	X.X	N	E	

◆ YUTAKI S COMBI

Unit type: YUTAKI S COMBI (Split system - Dual water module (Indoor unit + Domestic hot water tank) - Medium/Low temperature)										
Position-separating hyphen (fixed)										
Compressor power of the combined outdoor unit (HP): 2.0, 2.5, 3.0, 4.0, 5.0, 6.0.										
R-410A refrigerant										
Water-to-water DHW heat exchanger										
— : Standard model S : Model for solar combination										
Made in Europe										
Position-separating hyphen (fixed)										
Tank model: 200/260 L										
Tank material: Stainless steel										
-K: Model for UK market										
RWD	-	X.X	N	W	(X)	E	-	XXX	S	(-K)

◆ YUTAKI S80

Indoor unit

Unit type: YUTAKI S80 (Split system - Single water module (Indoor unit) - High & Very High temperature)

	Position-separating hyphen (fixed)		Compressor power (HP): 4.0, 5.0, 6.0.		V: Single phase unit (1~ 230V 50Hz) —: Three phase unit (3N~ 400V 50Hz)		R-410A refrigerant		R-134a refrigerant		—: Standalone version (Indoor unit alone or with DHW tank beside the indoor unit)		W: Integrated tank version (With DHW tank over the indoor unit)	
RWH	-	X.X	(V)	N	F	(W)	E	Made in Europe						

Domestic hot water tank (For combination with YUTAKI S80 indoor unit standalone version)

Unit type: YUTAKI S80 domestic hot water tank

	Model: 200/260 L		Stainless Steel		Position-separating hyphen (fixed)		Electric heater of 2.7 kW		Series		Made in Europe	
DHWS	XXX	S	-	2.7H	2	E						

1.3.1.3 Monobloc system

◆ YUTAKI M

Unit type: YUTAKI M (Monobloc system - Single water module (Outdoor unit) - Low/Medium temperature)



	Position-separating hyphen (fixed)		Compressor power (HP): 3.0, 4.0, 5.0, 6.0.		V: Single phase unit (1~ 230V 50Hz) —: Three phase unit (3N~ 400V 50Hz)		R-410A refrigerant		Made in Europe		
RASM	-	X.X	(X)	(V)	N	E					



1.3.2 Product guide







1.3.2.1 Split system - Outdoor unit



1~ 230V 50Hz				3N~ 400V 50Hz	
Unit	Code	Unit	Code	Unit	Code
RAS-2WHVNP	60288672	-	-	-	-
RAS-2.5WHVNP	60288673	-	-	-	-
RAS-3WHVNP	60288674	-	-	-	-
-	-	RAS-4WHVNPE	7E350007	RAS-4WHNPE	7E350107
-	-	RAS-5WHVNPE	7E350008	RAS-5WHNPE	7E350108
-	-	RAS-6WHVNPE	7E350009	RAS-6WHNPE	7E350109
-	-	-	-	RAS-8WHNPE	7E350110
-	-	-	-	RAS-10WHNPE	7E350111

1.3.2.2 Split system - Indoor unit

◆ YUTAKI S

     							
1~ 230V 50Hz				3N~ 400V 50Hz			
Unit	Code	Unit	Code	Unit	Code	Unit	Code
RWM-2.0NE	7E475003	-	-	-	-	-	-
RWM-2.5NE	7E475004	-	-	-	-	-	-
RWM-3.0NE	7E475005	-	-	-	-	-	-
-	-	RWM-4.0NE	7E475007	RWM-4.0NE	7E475007	-	-
-	-	RWM-5.0NE	7E475008	RWM-5.0NE	7E475008	-	-
-	-	RWM-6.0NE	7E475009	RWM-6.0NE	7E475009	-	-
-	-	-	-	-	-	RWM-8.0NE	7E475010
-	-	-	-	-	-	RWM-10.0NE	7E475011

i NOTE

Icons between brackets mean possible extra operations to the factory-supplied operations. For cooling operation, refer to the Cooling kit accessory for YUTAKI S units.

◆ YUTAKI S COMBI

i NOTE

Icons between brackets mean possible extra operations to the factory-supplied operations. For cooling operation, refer to the Cooling kit accessory for YUTAKI S COMBI units.

Standard model

			
1~ 230V 50Hz		3N~ 400V 50Hz	
Unit	Code	Unit	Code
RWD-2.0NWE-200S	7E483003	-	-
RWD-2.0NWE-260S	7E483016	-	-
RWD-2.5NWE-200S	7E483004	-	-
RWD-2.5NWE-260S	7E483017	-	-
RWD-3.0NWE-200S	7E483005	-	-
RWD-3.0NWE-260S	7E483018	-	-
RWD-4.0NWE-200S	7E483007	RWD-4.0NWE-200S	7E483007
RWD-4.0NWE-260S	7E483020	RWD-4.0NWE-260S	7E483020
RWD-5.0NWE-200S	7E483008	RWD-5.0NWE-200S	7E483008
RWD-5.0NWE-260S	7E483021	RWD-5.0NWE-260S	7E483021
RWD-6.0NWE-200S	7E483009	RWD-6.0NWE-200S	7E483009
RWD-6.0NWE-260S	7E483022	RWD-6.0NWE-260S	7E483022



Model for solar combination

			
1~ 230V 50Hz		3N~ 400V 50Hz	
Unit	Code	Unit	Code
RWD-2.0NWSE-260S	7E483316	-	-
RWD-2.5NWSE-260S	7E483317	-	-
RWD-3.0NWSE-260S	7E483318	-	-
RWD-4.0NWSE-260S	7E483320	RWD-4.0NWSE-260S	7E483320
RWD-5.0NWSE-260S	7E483321	RWD-5.0NWSE-260S	7E483321
RWD-6.0NWSE-260S	7E483322	RWD-6.0NWSE-260S	7E483322





Model for UK market

			
1~ 230V 50Hz		3N~ 400V 50Hz	
Unit	Code	Unit	Code
RWD-2.0NWE-200S-K	7E483203	-	-
RWD-2.0NWE-260S-K	7E483216	-	-
RWD-2.5NWE-200S-K	7E483204	-	-
RWD-2.5NWE-260S-K	7E483217	-	-
RWD-3.0NWE-200S-K	7E483205	-	-
RWD-3.0NWE-260S-K	7E483218	-	-
RWD-4.0NWE-200S-K	7E483207	RWD-4.0NWE-200S-K	7E483207
RWD-4.0NWE-260S-K	7E483220	RWD-4.0NWE-260S-K	7E483220
RWD-5.0NWE-200S-K	7E483208	RWD-5.0NWE-200S-K	7E483208
RWD-5.0NWE-260S-K	7E483221	RWD-5.0NWE-260S-K	7E483221
RWD-6.0NWE-200S-K	7E483209	RWD-6.0NWE-200S-K	7E483209
RWD-6.0NWE-260S-K	7E483222	RWD-6.0NWE-260S-K	7E483222



YUTAKI S80

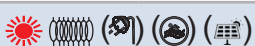

Indoor unit

							
TYPE 1: Version for operation in DHW but with a remote tank (Tank cannot be plugged on top of the unit)				TYPE 2: Version for operation with Hitachi DHW tank (Tank can be plugged on top of the unit or next to it)			
1~ 230V 50Hz		3N~ 400V 50Hz		1~ 230V 50Hz		3N~ 400V 50Hz	
Unit	Code	Unit	Code	Unit	Code	Unit	Code
RWH-4.0VNFE	7E482207	RWH-4.0NFE	7E482307	RWH-4.0VNFWE	7E482007	RWH-4.0NFWE	7E482107
RWH-5.0VNFE	7E482208	RWH-5.0NFE	7E482308	RWH-5.0VNFWE	7E482008	RWH-5.0NFWE	7E482108
RWH-6.0VNFE	7E482209	RWH-6.0NFE	7E482309	RWH-6.0VNFWE	7E482009	RWH-6.0NFWE	7E482109





YUTAKI S80 domestic hot water tank









 1~ 230V 50Hz			
Unit	Code	Unit	Code
DHWS200S-2.7H2E	7E544104	DHWS260S-2.7H2E	7E544105
			

i NOTE

- In "TYPE 1: Version for operation in DHW but with a remote tank", the required unit controller (PC-ARFHE) has to be ordered as accessory.
- In "TYPE 2: Version for operation with Hitachi DHW tank", the domestic hot water tank of model DHWS200S-2.7H2E or DHWS260S-2.7H2E is required. The DHW tank has to be ordered separately. The unit controller (PC-ARFHE) is factory-supplied with the DHW tank (integrated in the front cover).
- The tank can be installed in 2 ways: on top of the indoor unit (integrated installation) or next to it. In this second case, the specific accessory kit for installation (ATW-FWP-02), ordered as an accessory) is required.

1.3.2.3 Monobloc system

◆ YUTAKI M

     					
1~ 230V 50Hz				3N~ 400V 50Hz	
Unit	Code	Unit	Code	Unit	Code
RASM-3VNE	7E351005	-	-	-	-
-	-	RASM-4VNE	7E351007	RASM-4NE	7E351107
-	-	RASM-5VNE	7E351008	RASM-5NE	7E351108
-	-	RASM-6VNE	7E351009	RASM-6NE	7E351109
					

i NOTE

The required unit controller (PC-ARFHE) has to be ordered as an accessory.







1.3.3 Accessory code list

Model	Ref.
For all series	A
For YUTAKI S units	S
For YUTAKI S COMBI units	SC
For YUTAKI S80 units	S80
For YUTAKI M units	M

◆ Cooling kit accessories



Accessory	Ref.	Name	Code
NEW ATW-CKS-01	S	Cooling operation kit for YUTAKI S (For 2.0-3.0HP)	7E549927
NEW ATW-CKS-02	S	Cooling operation kit for YUTAKI S (For 4.0-6.0HP)	7E549928
NEW ATW-CKS-03	S	Cooling operation kit for YUTAKI S (For 8.0/10.0HP)	7E549929
NEW ATW-CKSC-01	SC	Cooling operation kit for YUTAKI S COMBI	7E549930
NEW ATW-CKM-01	M	Cooling operation kit for YUTAKI M	7E549931

◆ Control accessories

Accessory	Ref.	Name	Code	Figure
NEW PC-ARFHE	A	Unit controller Wired room thermostat for YUTAKI units (Languages EN/ES/DE/FR/IT)	7E543002	
NEW ATW-RTU-04	A	Wireless ON/OFF thermostat (Receiver + Room thermostat)	7E543003	
NEW ATW-RTU-05	A	Wireless Intelligent thermostat (Receiver + Room thermostat)	7E543004	
NEW ATW-RTU-06	A	Wireless Intelligent thermostat for 2nd circuit (Only Room thermostat. For Intelligent thermostat application)	7E543005	

Accessory	Ref.	Name	Code	Figure
NEW ATW-MBS-02	A	MODBUS gateway for YUTAKI units	7E549924	
NEW ATW-KNX-02	A	KNX interface for YUTAKI units	7E549925	
NEW ATW-TAG-02	A	Home automation gateway for Yutaki units	70549926	
NEW ATW-AOS-02	A	Auxiliary output signal box (Relay board for additional output signals)	7E549935	
NEW ATW-MAK-01	A	Kit for 4-20 mA application	7E549933	
NEW ATW-YMM-01	M	YUTAKI M remote control box (Slave)	7E549936	
NEW AHP-SMB-01	A	SmartBox (Hi-Box)	70549919	
NEW ATW-FCP-01	S SC S80	Unit controller cover	7E549938	

◆ Temperature sensor accessories

Accessory	Ref.	Name	Code	Figure
NEW ATW-2OS-02	A	2nd. outdoor temperature sensor	9E500017	
NEW ATW-ITS-01	A	Indoor wired room temperature sensor	7E549932	
ATW-WTS-02Y	A	Universal water temperature sensor	9E500004	

◆ Water circuit accessories

Accessory	Ref.	Name	Code	Figure
NEW ATW-2KT-03	SC	2nd zone mixing kit (Integrable in YUTAKI S COMBI 200 L model)	7E549921	
NEW ATW-2TK-04	A	2nd zone mixing kit (Wall mounted model)	7E549922	
NEW DHWT-200S-3.0H2E	S M	Domestic hot water tank (200 L)	70544002	
NEW DHWT-300S-3.0H2E	S80 (Type 1)	Domestic hot water tank (300 L)	70544003	
NEW ATW-FWP-02	S80 (Type 2)	Kit for installation with tank beside the indoor unit	7E549934	
ATW-HSK-01	A	Hydraulic separator	7E549905	
ATW-AQT-01	A	Aquastat security	7E549907	
ATW-3WV-01	A	3-way valve (Internal thread and spring return)	7E549906	
ATW-WCV-01	A	Water check valve	9E500014	
WEH-6E	S80 M	Water electric heater	90500002	
ATW-DPOV-01	A	Differential pressure overflow valve	7E549916	
NEW ATW-FWP-03	S80	Flexible water pipe	7E549937	

2. Features and benefits

Index

2.1	Selection benefits.....	16
2.1.1	Wide selection range.....	16
2.1.2	High efficiency system. Wide capacity range.....	19
2.1.3	Wide range of accessories and components.....	19
2.2	Installation benefits.....	26
2.2.1	YUTAKI S reduced dimensions.....	26
2.2.2	YUTAKI S80 improved connections.....	27
2.3	Maintenance benefits.....	28
2.3.1	Filter + for the water circuit.....	28
2.3.2	New manual air purger for YUTAKI S COMBI.....	28
2.4	Control features.....	29
2.4.1	Unit controller: more functions.....	29
2.4.2	I/O and sensor functions.....	29

























2.1 Selection benefits

2.1.1 Wide selection range

◆ **Range extension and renovation**

HITACHI extends the range of models adding a 2.5 HP unit to YUTAKI S and YUTAKI S COMBI series to complete an already wide range of possibilities to satisfy the customer needs.

In addition, all YUTAKI models have been renovated improving the structural components for a better performance. Their external parts, like covers, have been renovated, as well, providing a more pleasing aesthetic look.

Size/ Model	OUTDOOR UNIT	YUTAKI S	YUTAKI S COMBI	YUTAKI S80	YUTAKI M
2 HP				-	-
NEW 2.5 HP				-	-
3 HP				-	
4 HP					
5 HP					
6 HP					

Size/ Model	OUTDOOR UNIT	YUTAKI S	YUTAKI S COMBI	YUTAKI S80	YUTAKI M
8 HP			-	-	-
10 HP			-	-	-

2

◆ **YUTAKI S COMBI, special model for solar combination**

Although all YUTAKI models are ready for the use of solar panels to reduce the expenses on energy, YUTAKI S COMBI provides a tank for that purpose. A more compact solution to help to protect the environment and increase the energy efficiency.

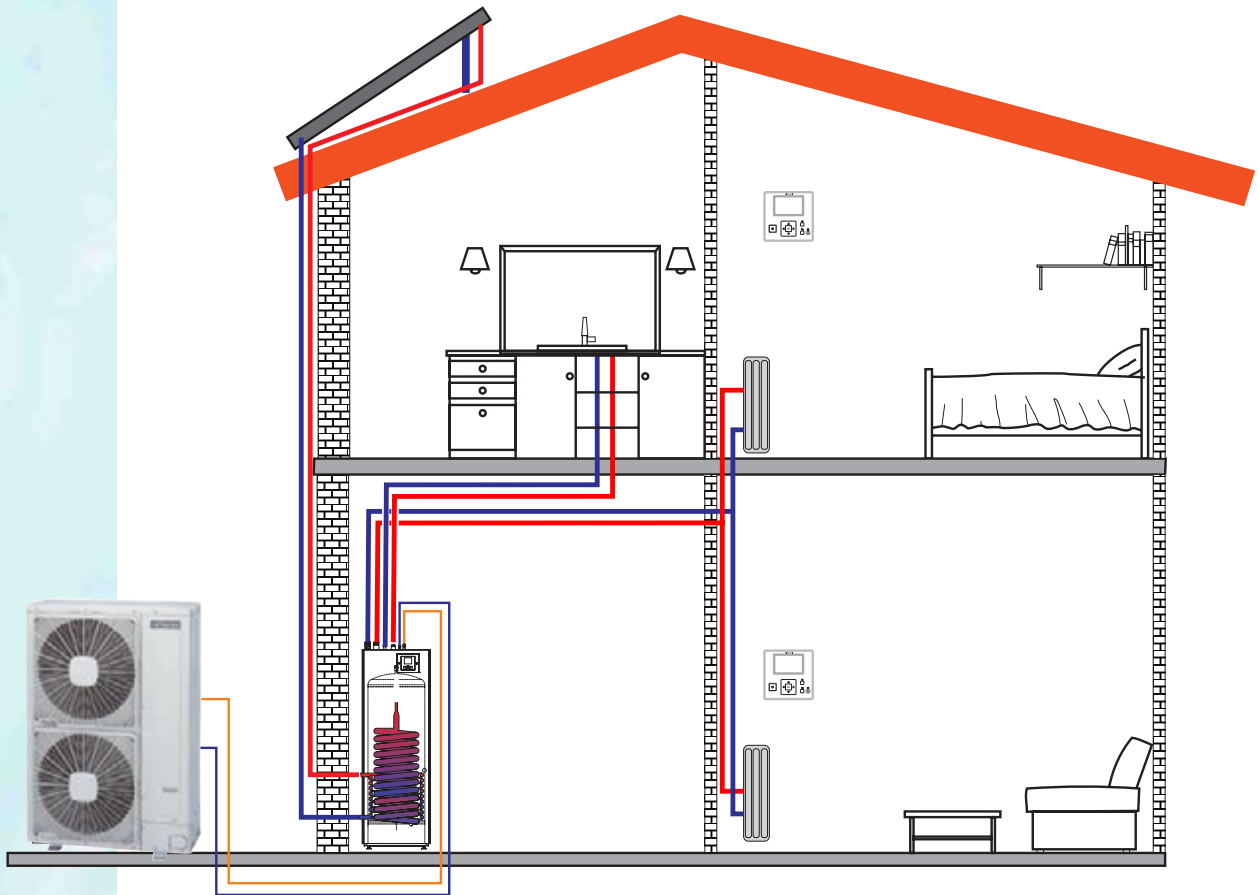

◆ **YUTAKI S COMBI, special model for UK market**

The new YUTAKI S COMBI series take into account the special regulations for the UK market. These models are equipped with additional safety devices such as:

- Pressure and temperature relief valve: This device protects the internal circuit of the tank when pressure is above 7 bar and when the temperature above 96° C. When this happens, this valve will perform a discharge to an alternative circuit.
- An additional thermostat (DHWT thermostat) protects the unit from temperatures above 85° C. The thermostat switches the pump off.

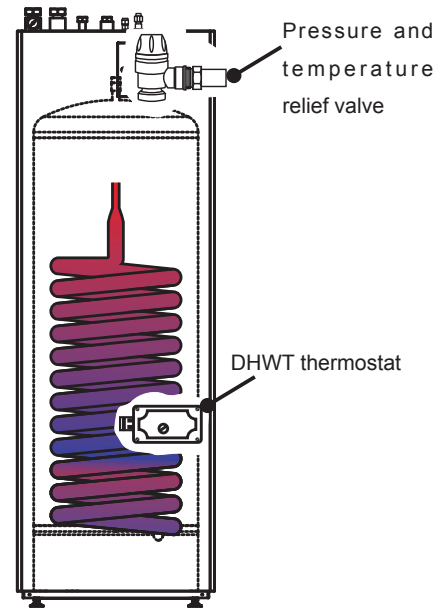

YUTAKI S80: Two new versions of indoor unit, improved flexibility

HITACHI offers for the new YUTAKI S80 series, two different versions of indoor unit ready to satisfy specific customer requirements:

Type	Heating	Heating + DHW	
<p>1. RWH-(V)NFE</p> <p>Version for operation in DHW but with a remote tank (Tank cannot be plugged on top of the unit)</p>		<p>Remote DHW tank beside the indoor unit.</p>	
<p>2. RWH-(V)NFE</p> <p>Version for operation with HITACHI DHW tank (Tank can be plugged on top of the unit or next to it)</p>		<p>HITACHI DHW tank beside the indoor unit.</p>	<p>HITACHI DHW tank integrated above the indoor unit.</p>

2.1.2 High efficiency system. Wide capacity range

◆ Increased efficiency

HITACHI announces an increase of the efficiency in all YUTAKI new models. The new YUTAKI S 2 HP, for example, increases its heating efficiency in nominal conditions up to a 5.25, the highest versus competitors.

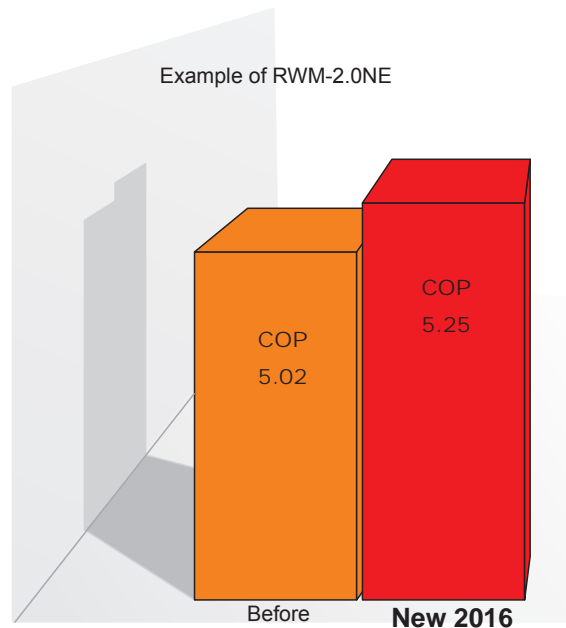

◆ Better SCOP

HITACHI announces an increase of **more than 15%** of seasonal heating efficiency thanks to the state-of-the-art technology of YUTAKI outdoor and indoor units.

◆ Bigger rated capacity

The nominal heating capacities of the new YUTAKI units have been increased in **+15%** roughly providing the required capacity for any situation.

2.1.3 Wide range of accessories and components

YUTAKI new models have been improved with new components and a wide range of accessories to ease the functionality and use of all the units.

◆ New wired unit controller

User-friendly

The new wired unit controller PC-ARFHE for all HITACHI YUTAKI models is more user-friendly and easy to use. It is more visually pleasant and even more intuitive.

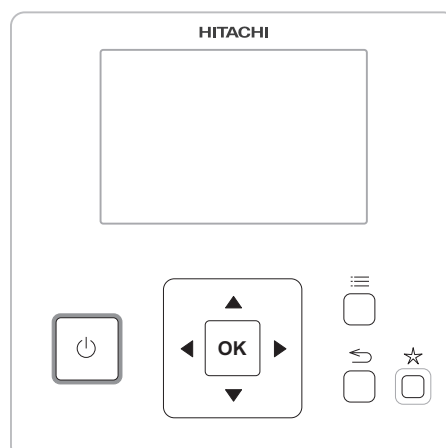

Selection benefits

Multifunction

The new unit controller is a multifunctional device with an updated hardware and an optimised software. Allows users to set up the unit to a wide range of possibilities.

Thermostat option (Up to 3 unit controller devices)

Now, the new unit controller can be used as a room thermostat. It can be removed from the front panel of the YUTAKI unit and placed anywhere it is needed, working as a thermostat to control the temperature in the area. Users can have the control of 2 different areas or even control the YUTAKI unit from 3 different places.

Unit controller supplied with the unit must always be the master type. It enables to configure parameters for the system and it can also be used as room thermostat.

OPTION 1

Use wired Unit controller PC-ARFHE + 2 thermostat option PC-ARFHE

- 1- Master unit controller as unit configuration with possibility to move to a living room.
- 2- Slave Unit controller as a room thermostat for Zone 1, as accessory
- 3- Slave Unit controller as a room thermostat for Zone 2, as accessory

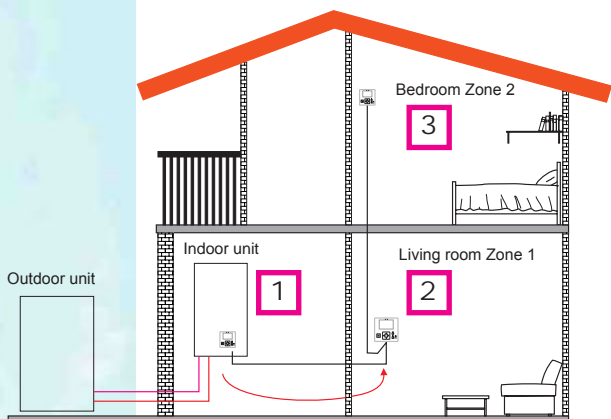

OPTION 2

Use wired Unit controller PC-ARFHE + 1 wired room sensors

- 1- No unit controller in the unit
- 2- Master Unit controller moved to living room Zone 1
- 3- Wired room sensor for Zone 2

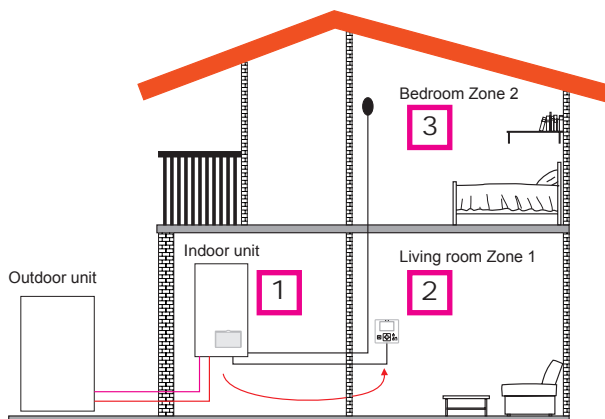

OPTION 3

Use wired Unit controller PC-ARFHE + 2 wired room sensor

- 1- Master unit controller as unit configuration.
- 2- Wired room sensor for Zone 1
- 3- Wired room sensor for Zone 2



OPTION 4

Use wired Unit controller PC-ARFHE + 1 unit controller as room thermostat PC-ARFHE + 1 wired room sensor

- 1- Master unit controller as unit configuration.
- 2- Wired unit controller a room thermostat for Zone 1
- 3- Wired room sensor for Zone 2

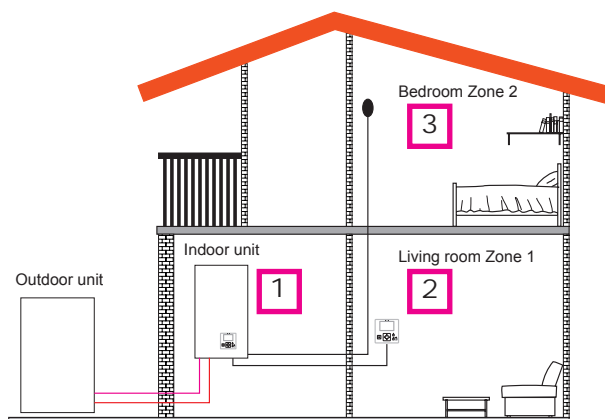

i NOTE

These examples are only for illustration purposes. Other types of installation configurations are possible.

◆ New wireless room thermostat

ON/OFF room thermostat unit

ON/OFF room thermostat unit is a user-friendly wireless room thermostat which informs Air-To-Water Heat Pump system when the room temperature reached the thermostat setting temperature and stops this water circuit operation.

The following illustration show the configuration applicable with the ATW-RTU-04 ON/OFF room thermostat unit.

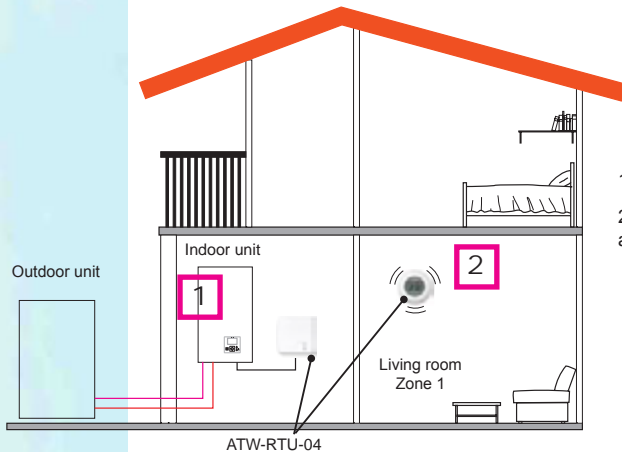

- 1- Master unit controller PC-ARFHE as unit configuration.
- 2- ON/OFF room thermostat (ATW-RTU-04) is connected to Indoor unit as a receiver of the Intelligent room thermostat signal in zone 2.

Intelligent Room Thermostat Unit

Intelligent Room Thermostat Unit is a user-friendly wireless room thermostat which informs Air-To-Water Heat Pump system about the room ambient temperature and the room set temperature in order to adjust the unit capacity considering how far it the ambient temperature.

This device is compounded of a receiver and one intelligent room unit thermostat for 1 room ambient control. It is possible to connect a second intelligent room unit thermostat (ATW-RTU-06) for a second room ambient control.

The following illustrations show different configurations applicable with the ATW-RTU-05 Intelligent room thermostat unit.

OPTION 1

- 1- Master unit controller PC-ARFHE as unit configuration.
- 2- Intelligent thermostat (ATW-RTU-05) is connected to Indoor unit as a receiver of the Intelligent room thermostat signal in zone 2.

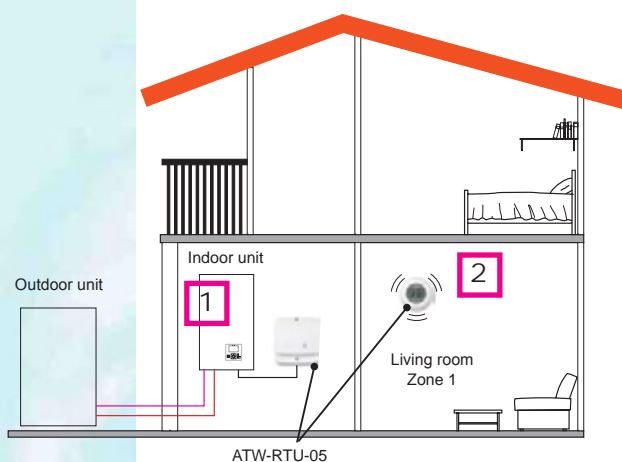

OPTION 2

- 1- Mater unit controller PC_ARFHE as unit configuration.
- 2- Intelligent thermostat (ATW-RTU-05) is connected to Indoor unit as a receiver of the Intelligent room thermostat signal from zone 2 and from zone 3.
- 3- Second room thermostat (ATW-RTU-06) as accessory in zone 3 for a second room ambient control.

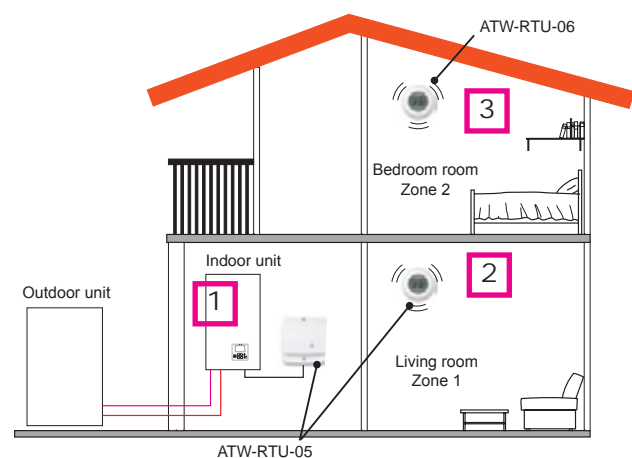

NOTE

These examples are only for illustration purposes. Other types of installation configurations are possible.

CAUTION

Wired and wireless thermostats cannot be combined in the same installation. A PC-ARFHE remote control switch should be installed an set up as Master unit controller

Selection benefits

◆ **New electrical box. More compact**

The new electrical box concept gathers all PCB in an all-in-one PCB main control, thus providing the following benefits:

- More compact
- More practical
- Easier maintenance
- Better inspection

YUTAKI S and S COMBI



YUTAKI S80

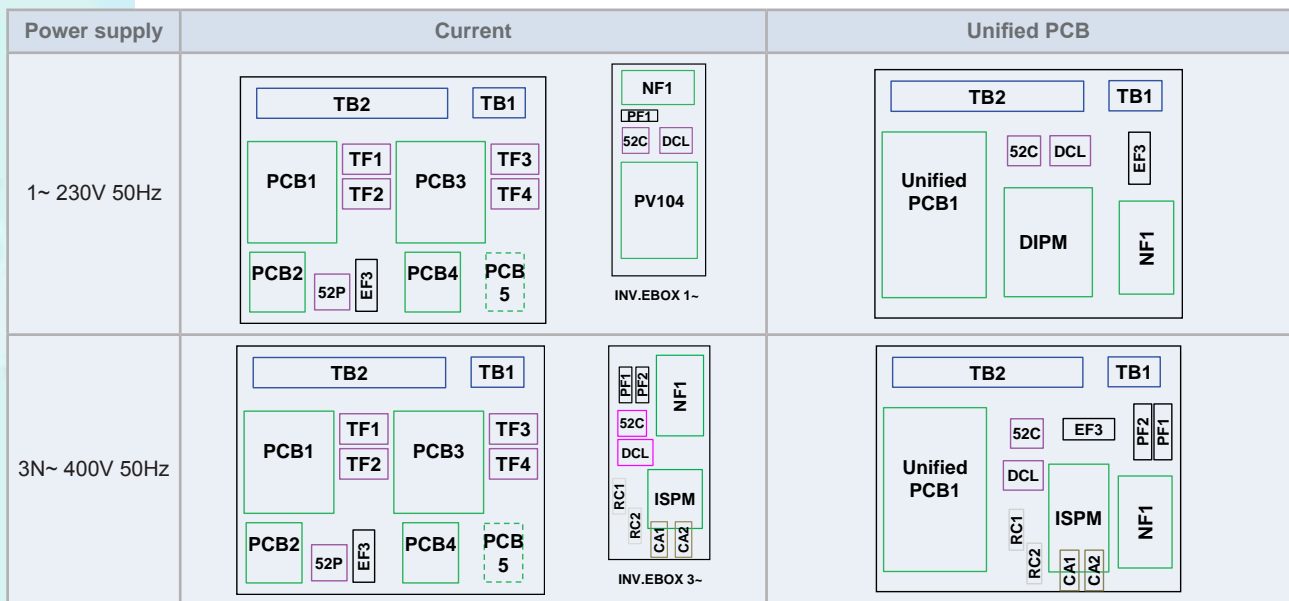

YUTAKI M

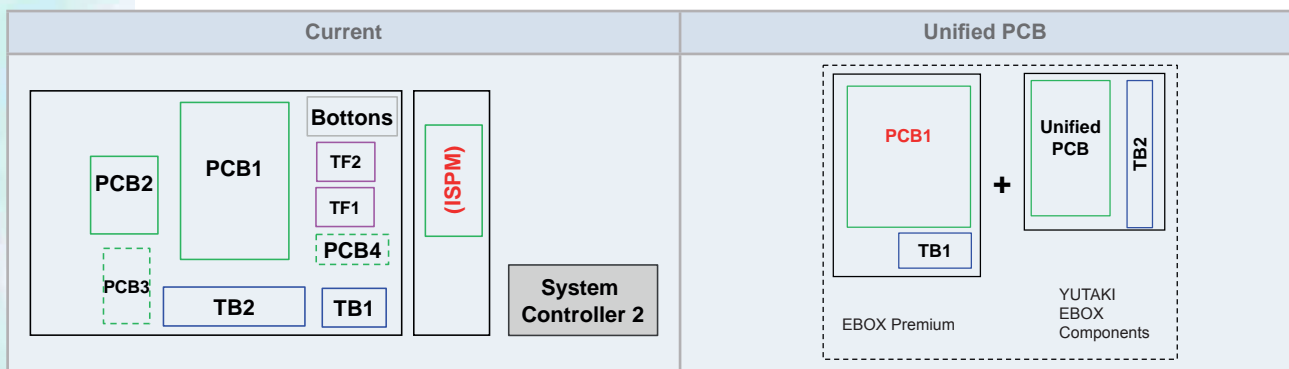

Selection benefits

◆ **New pumps (ErP compliant)**

From January 2015 the EU has legislated that all wet running circulators installed in central heating systems must conform with the ErP directive. The pump range covers many dimensions, pipe sizes and capacities for use in both existing and new applications. Fast and precise automatic capacity adjustments in response to changing operational conditions give increased energy savings. HITACHI YUTAKI pumps are ErP 2015(Tier2) compliant.



YUTAKI pumps have a reduced value of Energy Efficiency Index (EEI≤0.23), as defined by the Energy-related Products (ErP) Directive, which allows to classify these pumps as low water consumption pumps, resulting in a higher performance of the unit.

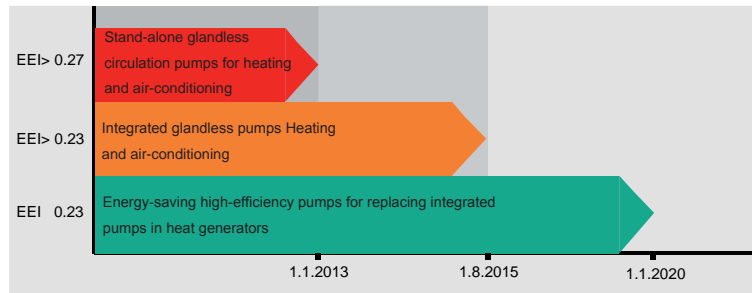

No need of water flow switch

Moreover, new YUTAKI pumps can read the rotation speed and the power consumption, crossing the power consumption measurement with the pump performance curves in order to know the water flow by electronic calculation. Therefore, using new YUTAKI pumps, there is no need of water flow switch.

◆ **YUTAKI M, improved**

The new YUTAKI M series has been improved with new components including the more compact electrical box with the new PCB, the more efficient heat plate exchanger (PHEX), the new water pump and a brand new structure and cycle. This makes the new YUTAKI M a model that exceeds all expectations.

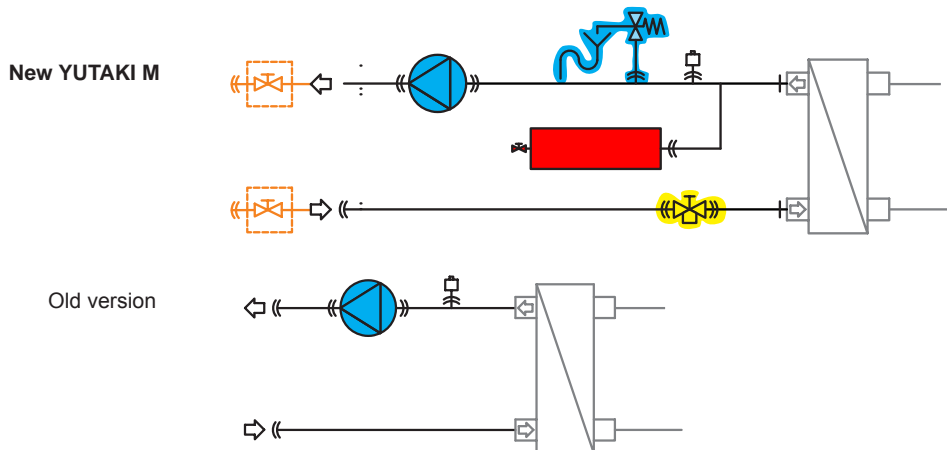

Item	Before	After
Water pump	Not included. Available as a HITACHI accessory	New component of the new YUTAKI M.
Shut-off valve	Not available	Factory-supplied accessory.
Safety valve	Not available	New component of the new YUTAKI M.
Water filter	Not available	New component of the new YUTAKI M.
Expansion vessel	Not available	New component of the new YUTAKI M.

◆ **Renovated YUTAKI outdoor units**

Outdoor 3, 8 and 10 HP units more compact

The new YUTAKI outdoor units have been reduced in size and weight , being more compact.

Units in mm.

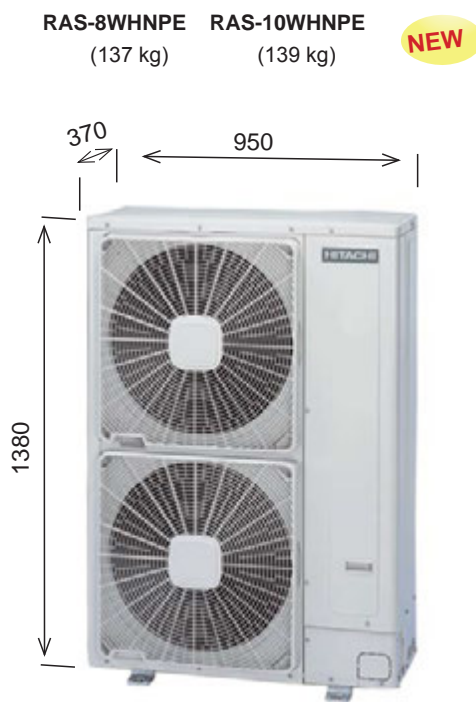
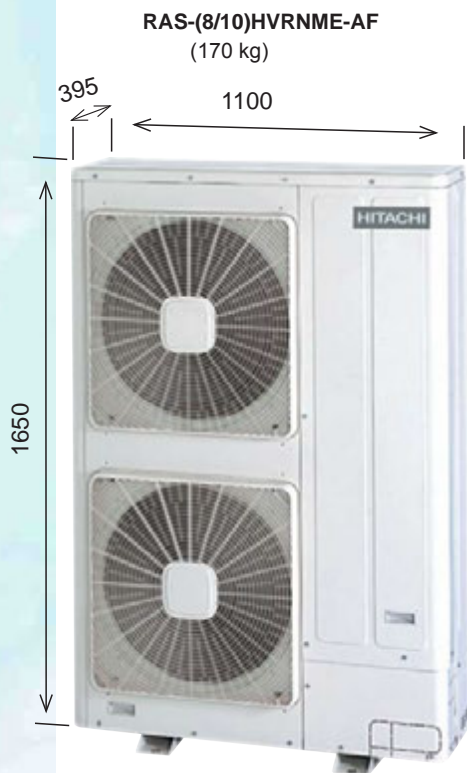
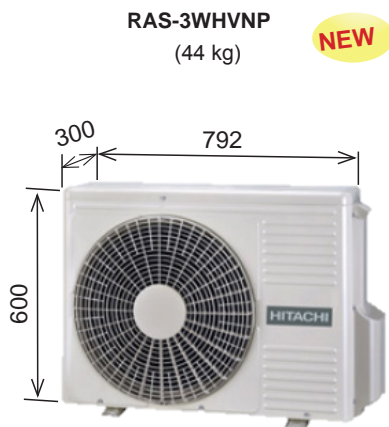
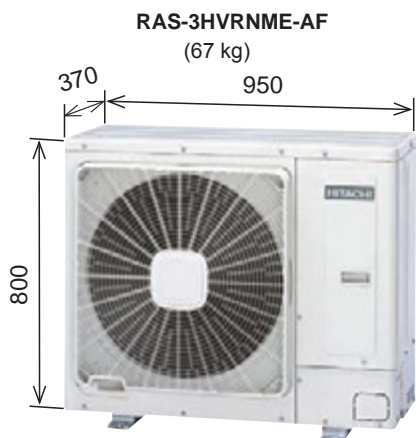

◆ **Optimised refrigerant cycle**

The new YUTAKI models have been improved and increased the efficiency with a new design of the refrigerant cycle. A new cycle for RAS series has been designed in order to go one step further:

Example for (4-6)HP

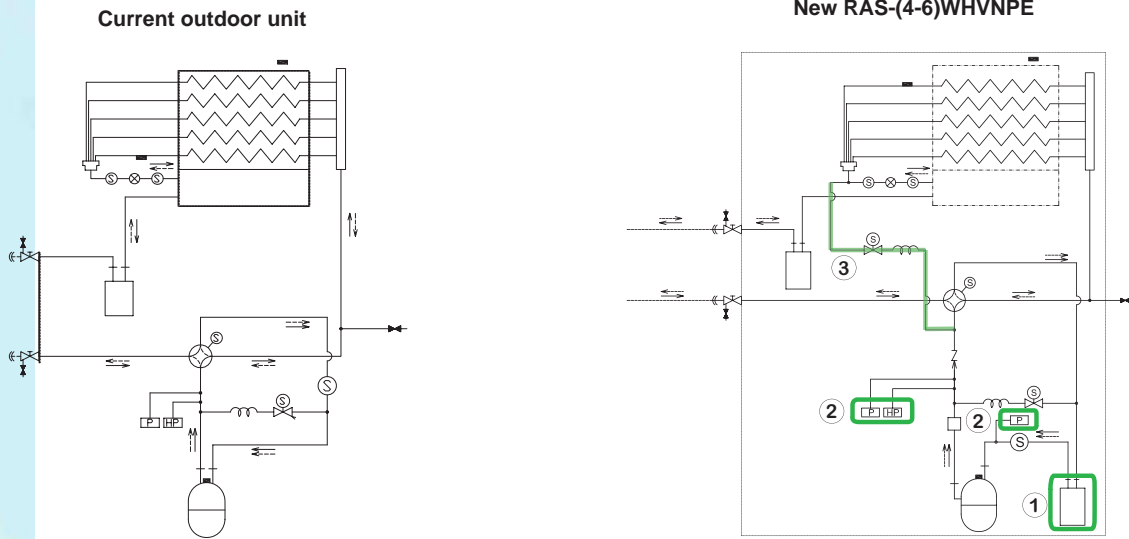

1.- New accumulator

The new accumulator used allows to optimise the amount of oil and refrigerant in each condition. As a result, the flexibility of combination has improved greatly.

2.- Improved pressure control

A new pressure switch for control has been attached to the suction side of the compressor. Additionally, the high pressure switch has been replaced with a pressure sensor to ensure a more accurate compressor control.

3.- Hot gas bypass to the heat exchanger

Part of the discharge gas is bypassed to the heat exchanger, making use of the surplus capacity of the RAS unit when the thermal load of the indoor unit is decreased.

◆ **New HITACHI scroll compressor**

The HITACHI DC INVERTER scroll compressor has been developed to increase seasonal efficiency and reliability, while reducing power input:

- ◆ High performance in intermediate season
- ◆ High efficiency at low speed (release valve and compacted winding of the DC INVERTER motor)

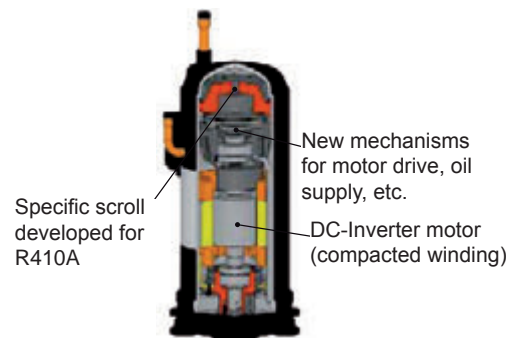

◆ **New electrical energy-saving reversing valve (Only for 4-10 HP)**

The new reversing valve achieves an important reduction in power consumption, which is specially remarkable when the unit is not operating (in standby mode). Thus, annual electricity costs are greatly improved.

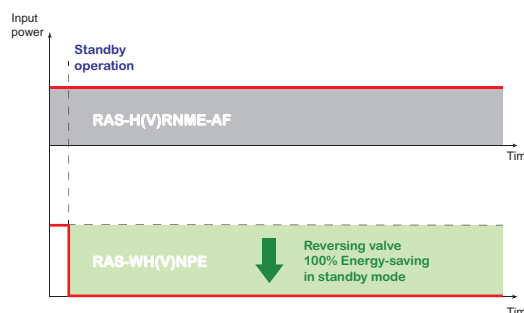
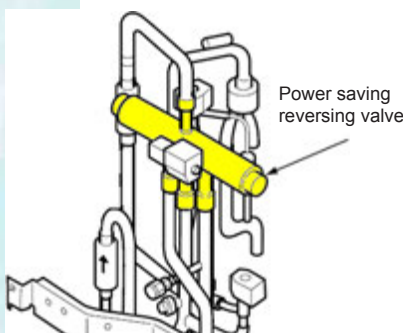

2.2 Installation benefits

2.2.1 YUTAKI S reduced dimensions

YUTAKI S (2.0-3.0)HP new models have been reduced in size and in weight with respect to previous models.

Units in mm

Previous YUTAKI S (2.0/3.0)HP

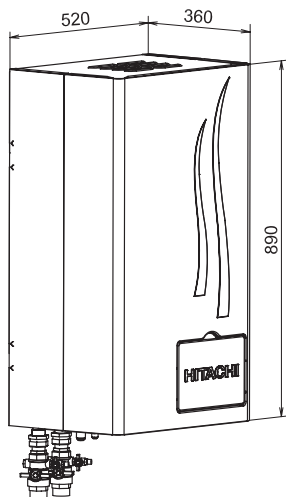

NEW YUTAKI S (2.0-2.5-3.0)HP

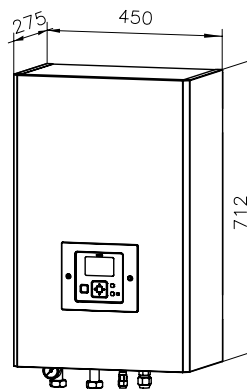

Now they have the dimensions to perfectly fit inside a kitchen cupboard, for example.

RWM-(2.0~3.0)NE

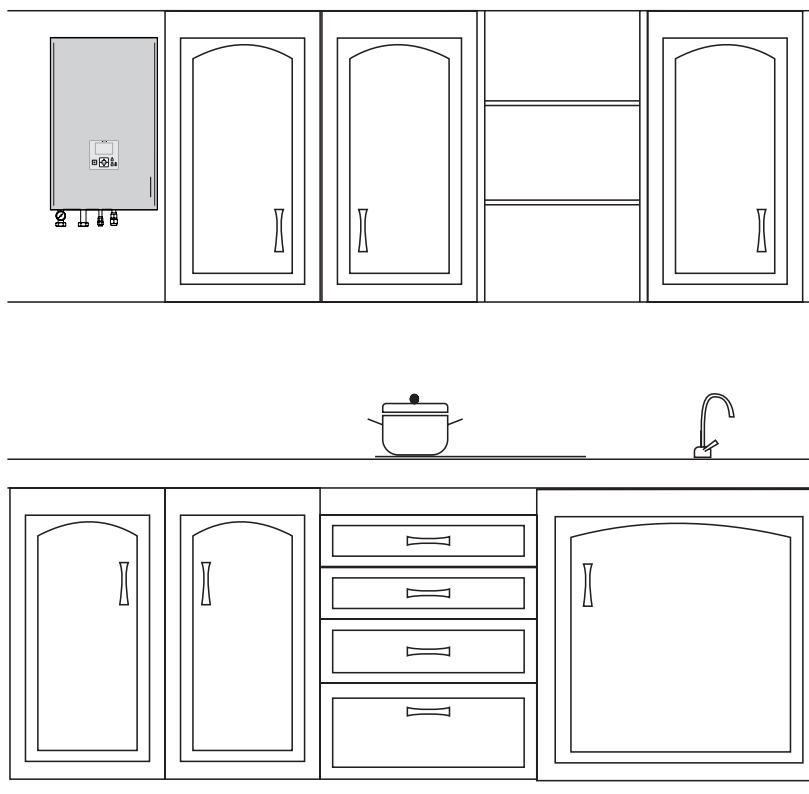

2.2.2 YUTAKI S80 improved connections

Water and refrigerant connections have been improved in order to give a more safe installation thus avoiding later problems with the installation.

TYPE 1: RWH-(V)NFE

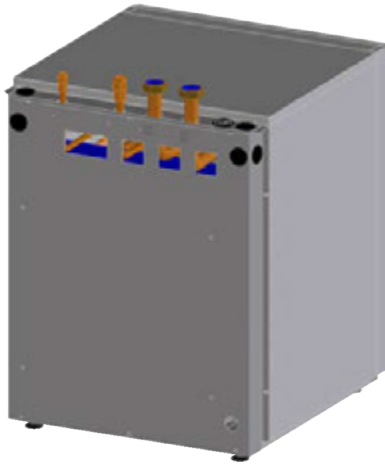

TYPE 2: RWH-(V)NFEWE



Professionals can now work with more efficiency and safety thanks to the new easy-to-install units of YUTAKI S80 series.

Water and refrigerant connections are now more accessible in all the models. Developers and designers have taken into account all the customers claims and specifications to match their requirements and needs.

2.3 Maintenance benefits

HITACHI YUTAKI series incorporates new components that make the maintenance an easier work to do. Aspects that makes the new YUTAKI series the most confident in the market:

- High quality components
- Longer life cycle assets
- More reliability-centered designs
- etc.

2.3.1 Filter + for the water circuit

Filter + is an on-off ball valve containing an interchangeable cylindrical filter which is easy to inspect and remove for normal maintenance operations. A single valve therefore has two important functions: perfect sealing of the ball valves and careful filtering of the fluid, so that their great reliability protects all the components of the new HITACHI YUTAKI units.

Compared with the traditional use of three components (one filter and two shut-off valves), apart from the obvious advantages in terms of cost, installation and space, the Filter + means much smaller load losses.

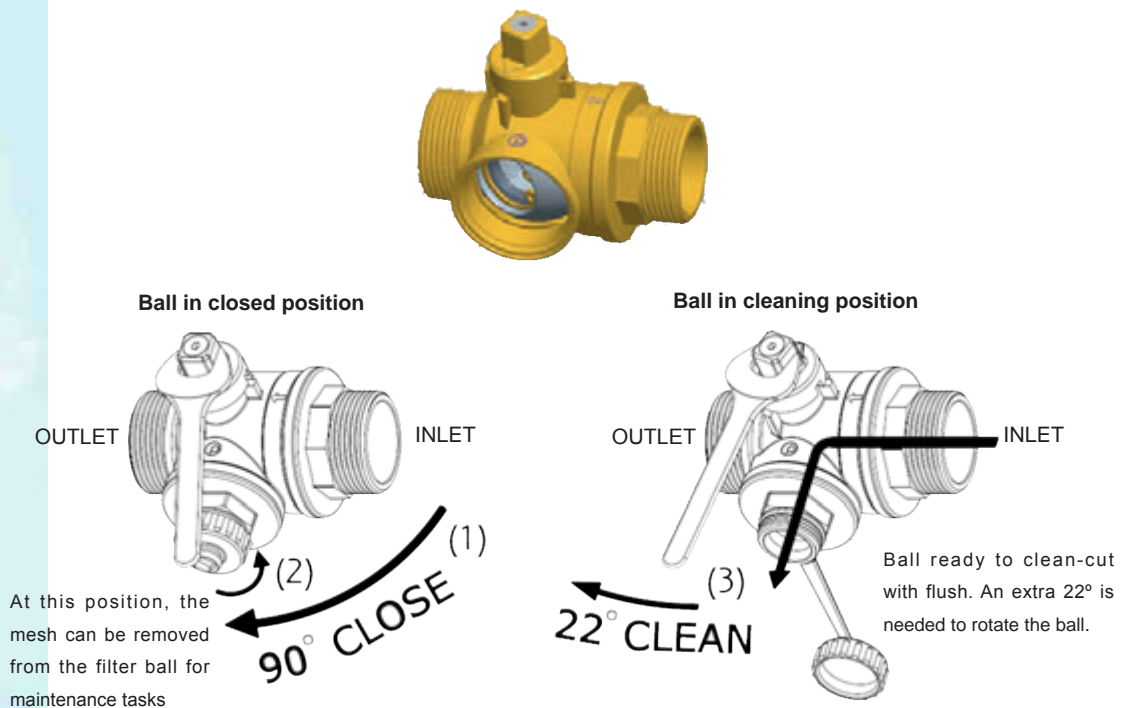

2.3.2 New manual air purger for YUTAKI S COMBI

HITACHI includes a manual air purger for the new YUTAKI S COMBI models to improve maintenance operation.

Following the advice of technicians worldwide, for the maintenance operations in which the emptying of the water in the circuit is necessary, the location of this manual air purger provides better operations for the purging of the air contained inside the circuit.

2.4 Control features

2.4.1 Unit controller: more functions

The new HITACHI YUTAKI series incorporate a new unit controller which provides a great deal of functions. Some of the special functions are:

- Wizard Start-up configuration: It makes easier the Start-up of the system.
- Auto cool/heat
- Quick actions menu for more comprehensive view: Functions Timer, ECO, Status, Schedule and OTC.
- Boost action: It allows an immediate heating of the domestic hot water.
- Improved timer: Better aesthetic and function of simple timer to create easily a timer configuration.
- Air purge function for the test run.
- Many other improvements like: possibility to modify the name of the circuits, configuration of phone contact, etc.

2.4.2 I/O and sensor functions

The new YUTAKI models have a wide range of configurations. Added to the factory presets, there is a wide variety of possible different input, output and sensor settings that can be performed from the unit controller.

The factory-set functions of the controller are those indicated in the label of the terminal board 2 of the indoor unit:

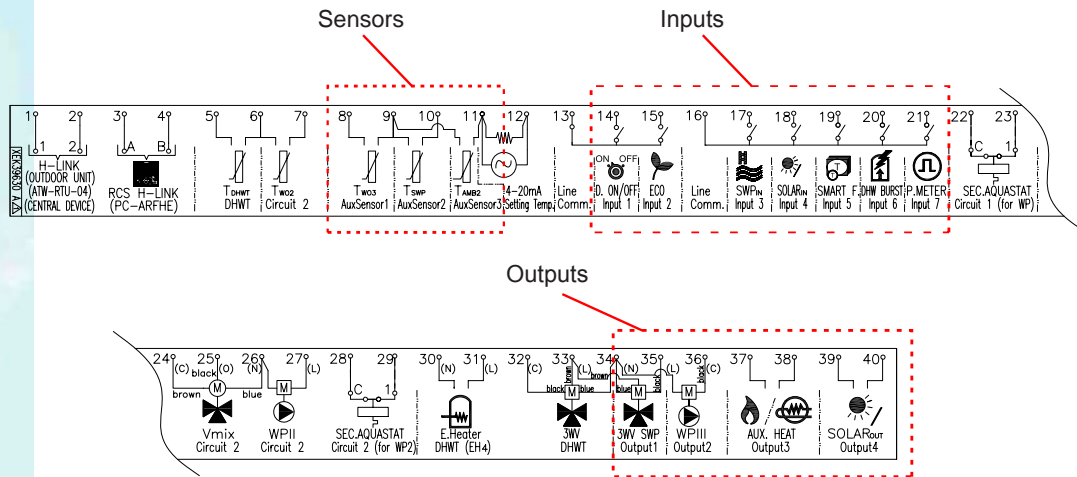

The following input, output and sensor functions can be selected through the “I/O and sensor” menu of the controller:

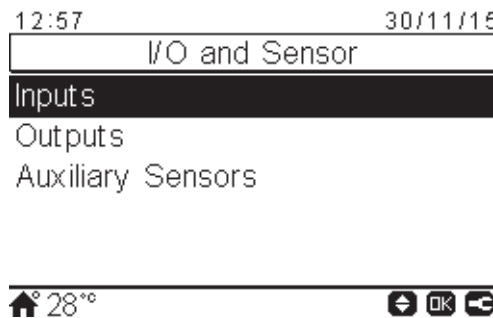

- Inputs: Demand ON/OFF, Smart act., Swimming pool input, Solar, Operation mode, DHW boost, Power Meter 1, Demand ON/OFF C1, Demand ON/FF C2, Forced heating, Forced cooling, Power meter 2, ECO mode C1 and C2, ECO mode C1, ECO mode C2, Forced OFF, SG 2.
- Outputs: 3-way valve swimming pool, water pump 3, Boiler, Solar pump, Alarm, Operation, Cooling, Demand-ON C1, Heating, DHW, Defrost, DHW recirculation, Heater relay 1, Heater relay 2.
- Sensors: Two3, Swimming pool, Solar panel sensor, C1 & C2 ambient, C1 ambient, C2 ambient, Outdoor sensor (NTC).

3. General data

Index

3.1	Capacity tables.....	32
3.1.1	Nominal capacity-performance tables.....	32
3.1.1.1	Considerations.....	32
3.1.1.2	Capacity-performance data.....	32
3.2	ERP performance data.....	35
3.2.1	General considerations.....	35
3.2.2	General ERP data for space heaters.....	35
3.2.2.1	ERP data - YUTAKI S.....	35
3.2.2.2	ERP data - YUTAKI S COMBI.....	41
3.2.2.3	ERP data - YUTAKI S80.....	46
3.2.2.4	ERP data - YUTAKI M.....	49
3.2.2.5	ERP additional data - YUTAKI S.....	52
3.2.2.6	ERP additional data - YUTAKI S COMBI.....	53
3.2.2.7	ERP additional data - YUTAKI S80.....	54
3.2.3	General ERP data for combi heaters (YUTAKI S COMBI & S80).....	55
3.2.3.1	YUTAKI S COMBI.....	55
3.2.3.2	YUTAKI S80.....	56
3.2.4	General ERP data for hot water storage tanks (YUTAKI S , YUTAKI M & YUTAKI S 80 RWH-4.0VNFE.....	56
3.3	General specifications.....	57
3.3.1	Considerations.....	57
3.3.2	Split system - Outdoor unit.....	58
3.3.3	Split system - Indoor unit.....	60
3.3.3.1	YUTAKI S.....	60
3.3.3.2	YUTAKI S COMBI.....	63
3.3.3.3	YUTAKI S80.....	69
3.3.4	Monobloc system - YUTAKI M.....	72
3.3.5	Domestic Hot Water Tank.....	74
3.4	Component data.....	75
3.4.1	Split system - Outdoor unit.....	75
3.4.2	Split system - Indoor unit.....	77
3.4.2.1	YUTAKI S.....	77
3.4.2.2	YUTAKI S COMBI.....	78
3.4.2.3	YUTAKI S80.....	82
3.4.3	Monobloc system - YUTAKI M.....	83
3.5	Electrical data.....	85
3.5.1	Considerations.....	85
3.5.2	Split system - Outdoor unit.....	86
3.5.3	Split system - Indoor unit.....	87
3.5.3.1	YUTAKI S.....	87
3.5.3.2	YUTAKI S COMBI.....	87
3.5.3.3	YUTAKI S80.....	88
3.5.4	Monobloc system - YUTAKI M.....	90

3.1 Capacity tables

3.1.1 Nominal capacity-performance tables

3.1.1.1 Considerations

- The heating capacity tables show the capacity and performance data in integrated values (with defrost correction factor included).
- The nominal heating and cooling capacities are based on the EN 14511 standard: Piping length: 7.5 meters; Piping lift: 0 meters.

Keywords:

- CAP: Nominal capacity (kW)
- COP: Coefficient of performance
- EER: Energy efficiency ratio
- DB: Dry bulb; WB: Wet bulb (°C)
- OAT: Outdoor ambient temperature (°C)
- WIT: Water inlet temperature (°C)
- WOT: Water outlet temperature (°C)

3.1.1.2 Capacity-performance data

◆ YUTAKI S

Outdoor unit model				RAS-2 WHVNP	RAS-2.5 WHVNP	RAS-3 WHVNP	RAS-4 WH(V)NPE	RAS-5 WH(V)NPE	RAS-6 WH(V)NPE	RAS-8 WHNPE	RAS-10 WHNPE
Indoor unit model				RWM-2.0 NE	RWM-2.5 NE	RWM-3.0 NE	RWM-4.0 NE	RWM-5.0 NE	RWM-6.0 NE	RWM-8.0 NE	RWM-10.0 NE
OAT (DB/WB)	WIT / WOT	-	Unit	Heating operation							
7 / 6 °C	30 / 35 °C	CAP (Min /Nom./Max.)	kW	1.85 /4.3/7.0	1.95 /6.0/9.0	2.1/ 7.5/11.0	4.3 /11.0/15.2	4.8 /14.0/16.7	5.5 /16.0/17.8	9.0 /20.0/25.5	10.0 /24.0/32.0
		COP (Nom.)	-	5.25	4.80	4.55	5.00	4.71	4.57	4.30	4.29
	40 / 45 °C	CAP (Nom./Max.)	kW	4.3/6.2	6.0/9.0	7.5/10.0	11.0/14.1	14.0/15.7	16.0/17.3	20.0/25.0	24.0/32.0
		COP (Nom.)	-	3.90	3.59	3.50	3.98	3.61	3.40	3.40	3.30
	47 / 55 °C	CAP (Nom./Max.)	kW	4.3/6.0	6.0/8.0	7.5/9.2	11.0/13.5	14.0/15.2	16.0/17.0	20.0/24.0	24.0/32.0
		COP (Nom.)	-	3.00	2.89	2.57	3.00	2.80	2.50	2.72	2.65
2 / 1 °C	30 / 35 °C	CAP (Nom./Max.)	kW	3.5/5.5	4.5/7.0	5.5/8.9	9.5/12.8	10.5/13.9	11.1/15.0	12.3/20.0	13.0/20.7
		COP (Nom.)	-	4.10	3.65	3.53	3.61	3.55	3.41	3.41	3.31
-7 / -8 °C	30 / 35 °C	CAP (Nom./Max.)	kW	4.3/4.7	5.3/5.7	5.8/6.7	9.7/10.6	11.5/12.0	12.0/13.0	14.2/17.9	16.5/21.0
		COP (Nom.)	-	2.85	2.60	2.57	2.74	2.65	2.57	2.57	2.46
	40 / 45 °C	CAP (Nom./Max.)	kW	4.3/4.6	5.0/5.5	6.0/6.4	10.0/10.0	11.0/11.6	11.5/12.5	15.0/16.6	16.5/18.5
		COP (Nom.)	-	2.45	2.25	2.25	2.45	2.25	2.15	2.08	1.74
	47 / 55 °C	CAP (Nom./Max.)	kW	4.0/4.2	4.6/5.0	5.0/5.5	8.7/9.7	9.7/11.2	10.5/12.0	12.5/14.5	15.5/17.3
		COP (Nom.)	-	1.93	1.82	1.60	1.78	1.85	1.75	1.70	1.50

OAT (DB/WB)	WIT / WOT	-	Unit	Cooling operation (Using cooling kit accessory)							
35 / -- °C	12 / 7 °C	CAP (Nom/Max)	kW	3.8/4.9	5.0/5.8	6.0/7.0	7.2/11.8	9.5/12.6	10.5/13.7	14.0/16.4	17.5/20.6
		EER (Nom.)	-	3.12	3.15	2.75	3.30	3.54	3.31	3.12	2.81
	23 / 18 °C	CAP (Nom/Max)	kW	4.1/6.1	5.5/7.4	6.0/8.5	10.4/15.0	12.9/16.0	13.5/17.5	17.0/23.5	20.0/27.0
		EER (Nom.)	-	3.81	3.81	3.81	4.50	4.02	3.81	3.81	3.61

◆ YUTAKI S COMBI

Outdoor unit model				RAS-2 WHVNP	RAS-2.5 WHVNP	RAS-3 WHVNP	RAS-4 WH(V)NPE	RAS-5 WH(V)NPE	RAS-6 WH(V)NPE
Indoor unit model				RWD-2.0 NW(S)E- (200/260)S(-K)	RWD-2.5 NW(S)E- (200/260)S(-K)	RWD-3.0 NW(S)E- (200/260)S(-K)	RWD-4.0 NW(S)E- (200/260)S(-K)	RWD-5.0 NW(S)E- (200/260)S(-K)	RWD-6.0 NW(S)E- (200/260)S(-K)
OAT (DB/WB)	WIT / WOT	-	Unit	Heating operation					
7 / 6 °C	30 / 35 °C	CAP (Min /Nom./Max.)	kW	1.85 /4.3/7.0	1.95 /6.0/9.0	2.1/ 7.5/11.0	4.3 /11.0/15.2	4.8 /14.0/16.7	5.5 /16.0/17.8
		COP (Nom.)	-	5.25	4.80	4.55	5.00	4.71	4.57
	40 / 45 °C	CAP (Nom./Max.)	kW	4.3/6.2	6.0/9.0	7.5/10.0	11.0/14.1	14.0/15.7	16.0/17.3
		COP (Nom.)	-	3.90	3.59	3.50	3.98	3.61	3.40
	47 / 55 °C	CAP (Nom./Max.)	kW	4.3/6.0	6.0/8.0	7.5/9.2	11.0/13.5	14.0/15.2	16.0/17.0
		COP (Nom.)	-	3.0	2.89	2.57	3.00	2.80	2.50
2 / 1 °C	30 / 35 °C	CAP (Nom./Max.)	kW	3.5/5.5	4.5/7.0	5.5/8.9	9.5/12.8	10.5/13.9	11.1/15.0
		COP (Nom.)	-	4.10	3.65	3.53	3.61	3.55	3.41
-7 / -8 °C	30 / 35 °C	CAP (Nom./Max.)	kW	4.3/4.7	5.3/5.7	5.8/6.7	9.7/10.6	11.5/12.0	12.0/13.0
		COP (Nom.)	-	2.85	2.60	2.57	2.74	2.65	2.57
	40 / 45 °C	CAP (Nom./Max.)	kW	4.3/4.6	5.0/5.5	6.0/6.4	10.0/10.0	11.0/11.6	11.5/12.5
		COP (Nom.)	-	2.45	2.25	2.25	2.45	2.25	2.15
	47 / 55 °C	CAP (Nom./Max.)	kW	4.0/4.2	4.6/5.0	5.0/5.5	8.7/9.7	9.7/11.2	10.5/12.0
		COP (Nom.)	-	1.93	1.82	1.60	1.78	1.85	1.75

OAT (DB/WB)	WIT / WOT	-	Unit	Cooling operation (Using cooling kit accessory)					
35 / -- °C	12 / 7 °C	CAP (Nom/Max)	kW	3.8/4.9	5.0/5.8	6.0/7.0	7.2/11.8	9.5/12.6	10.5/13.7
		EER (Nom.)	-	3.12	3.15	2.75	3.30	3.54	3.31
	23 / 18 °C	CAP (Nom/Max)	kW	4.1/6.1	5.5/7.4	6.0/8.5	10.4/15.0	12.9/16.0	13.5/17.5
		EER (Nom.)	-	3.81	3.81	3.81	4.50	4.02	3.81

◆ YUTAKI S COMBI tank performance

Tank			RAS-2 WHVNP	RAS-2.5 WHVNP	RAS-3 WHVNP	RAS-4 WHVNP	RAS-5 WHVNP	RAS-6 WHVNP	RAS-4 WHNPE	RAS-5 WHNPE	RAS-6 WHNPE
			RWD-2.0 NW(S)E- (200/260) S(-K)	RWD-2.5 NW(S)E- (200/260) S(-K)	RWD-3.0 NW(S)E- (200/260) S(-K)	RWD-4.0 NW(S)E- (200/260) S(-K)	RWD-5.0 NW(S)E- (200/260) S(-K)	RWD-6.0 NW(S)E- (200/260) S(-K)	RWD-4.0 NW(S)E- (200/260) S(-K)	RWD-5.0 NW(S)E- (200/260) S(-K)	RWD-6.0 NW(S)E- (200/260) S(-K)
200 L	Tapping	-	L	L	L	L	L	L	L	L	L
	COPdhw	-	3.30	3.30	3.30	3.25	3.25	3.25	3.25	3.25	3.25
	Pes	W	0.037	0.037	0.037	0.042	0.042	0.042	0.049	0.049	0.49
	Vmax	L	263	263	263	263	263	263	263	263	263
	Owh'	°C	54.00	54.00	54.00	54.00	54.00	54.00	54.00	54.00	54.00
	eta	%	132	132	132	130	130	130	130	130	130
	Class	-	A+	A+	A+	A+	A+	A+	A+	A+	A+
260 L	Tapping	-	XL	XL	XL	XL	XL	XL	XL	XL	XL
	COPdhw	-	3.40	3.40	3.40	3.35	3.35	3.35	3.35	3.35	3.35
	Pes	W	0.041	0.041	0.041	0.044	0.044	0.044	0.051	0.051	0.051
	Vmax	L	350	350	350	350	350	350	350	350	350
	Owh'	°C	54.00	54.00	54.00	54.00	54.00	54.00	54.00	54.00	54.00
	eta	%	136	136	136	134	134	134	134	134	134
	Class	-	A+	A+	A+	A+	A+	A+	A+	A+	A+

◆ YUTAKI S80

Outdoor unit model				RAS-4WH(V)NPE	RAS-5WH(V)NPE	RAS-6WH(V)NPE
Indoor unit model				RWH-4.0(V)NF(W)E	RWH-5.0(V)NF(W)E	RWH-6.0(V)NF(W)E
OAT (DB/WB)	WIT / WOT	-	Unit	Heating operation		
7 / 6 °C	30 / 35 °C	CAP (Nom./Max.)	kW	11.0/15.2	14.0/16.7	16.0/17.8
		COP (Nom.)	-	5.00	4.71	4.57
	40 / 45 °C	CAP (Nom./Max.)	kW	11.0/14.5	14.0/17.0	16.0/18.0
		COP (Nom.)	-	3.90	3.78	3.60
	47 / 55 °C	CAP (Nom./Max.)	kW	11.0/14.5	14.0/17.0	16.0/18.0
		COP (Nom.)	-	3.32	3.19	3.10
55 / 65 °C	CAP (Nom./Max.)	kW	11.0/14.5	14.0/17.0	16.0/18.0	
	COP (Nom.)	-	2.90	2.88	2.73	
-7 / -8 °C	30 / 35 °C	CAP (Nom./Max.)	kW	9.7/10.6	11.5/12.2	12.1/13.0
		COP (Nom.)	-	2.74	2.65	2.57
	40 / 45 °C	CAP (Nom./Max.)	kW	11.0/12.5	14.0/14.5	16.0/16.0
		COP (Nom.)	-	2.40	2.30	2.20
	47 / 55 °C	CAP (Nom./Max.)	kW	11.0/12.5	14.0/14.5	16.0/16.0
		COP (Nom.)	-	2.30	2.20	2.08
	55 / 65 °C	CAP (Nom./Max.)	kW	11.0/12.5	14.0/14.5	16.0/16.0
		COP (Nom.)	-	2.10	2.05	1.95

◆ YUTAKI M

Outdoor unit model				RASM-3VNE	RASM-4VNE	RASM-5VNE	RASM-6VNE
OAT (DB/WB)	WIT / WOT	-	Unit	Heating operation			
7 / 6 °C	30 / 35 °C	CAP (Nom./Max.)	kW	7.5/11.0	11.0/15.2	14.0/16.7	16.0/17.8
		COP (Nom.)	-	4.55	5.00	4.71	4.57
	40 / 45 °C	CAP (Nom./Max.)	kW	7.5/10.0	11.0/14.1	14.0/15.7	16.0/17.3
		COP (Nom.)	-	3.50	3.80	3.61	3.40
	47 / 55 °C	CAP (Nom./Max.)	kW	7.5/9.2	11.0/13.5	14.0/15.2	16.0/17.0
		COP (Nom.)	-	2.70	3.00	2.80	2.50
2 / 1 °C	30 / 35 °C	CAP (Nom./Max.)	kW	5.5/8.9	9.5/12.8	10.5/13.9	11.1/15.0
		COP (Nom.)	-	3.53	3.70	3.55	3.41
-7 / -8 °C	30 / 35 °C	CAP (Nom./Max.)	kW	6.0/6.7	9.7/10.6	11.5/12.0	12.0/13.0
		COP (Nom.)	-	2.57	2.74	2.65	2.57
	40 / 45 °C	CAP (Nom./Max.)	kW	5.5/6.4	10.0/10.3	11.0/11.6	11.5/12.5
		COP (Nom.)	-	2.25	2.45	2.25	2.15
	47 / 55 °C	CAP (Nom./Max.)	kW	5.5/5.5	8.7/9.8	9.7/11.2	10.5/12.0
		COP (Nom.)	-	1.72	1.78	1.85	1.75

OAT (DB/WB)	WIT / WOT	-	Unit	Cooling operation (Using cooling kit accessory)			
35 / -- °C	12 / 7 °C	CAP (Nom/Max)	kW	6.0/7.0	7.2/11.8	9.5/12.6	10.5/13.7
		EER (Nom.)	-	2.75	3.30	3.54	3.31
	23 / 18 °C	CAP (Nom/Max)	kW	6.0/8.5	10.4/15.0	12.9/16.0	13.5/17.5
		EER (Nom.)	-	3.81	4.50	4.02	3.81

3.2 ERP performance data

3.2.1 General considerations

- This appliance must be installed, maintained and dismantled by professionals. Do not pour contained refrigerant into the atmosphere since this refrigerant fluid is a fluorinated greenhouse gas regulated under European Regulation (EU) No 517/2014.
- Data with the mark (*) corresponds to the "Energy efficiency contribution (η_g)" due to the use of temperature control.

OTC control (Factory-supplied)		Wired room thermostat (PC-ARFHE)		7E543002 (*)		
		Wireless room thermostat (ATW-RTU-04)		7E543003		
		Wired room sensor (ATW-ITS-01)		7E549932		
Temperature control class	II	Temperature control class	VI			
Energy efficiency contribution	+2%	Contribution to the nominal energy efficiency	+4%			

(*) Factory supplied in case of YUTAKI S, SC and S80 DHW Tank

- Data between brackets corresponds only to heating and cooling models ("Cooling kit" accessory needed).**

3.2.2 General ERP data for space heaters

3.2.2.1 ERP data - YUTAKI S

◆ AVERAGE climate

RAS-(2-3)WHVNP + RWM-(2.0-3.0)NE

Model		Outdoor unit		RAS-2WHVNP		RAS-2.5WHVNP		RAS-3WHVNP	
		Indoor unit		RWM-2.0NE		RWM-2.5NE		RWM-3.0NE	
Water outlet temperature				35°C	55°C	35°C	55°C	35°C	55°C
Product description	Air to water heat pump	-		Yes					
	Heat pump combination heater	-		No					
	Low temperature heat pump	-		No					
	Complementary heater	-		Yes					
Design capacity (P_{DESIGN})		kW	4.0	4.0	6.0	5.0	7.0	6.0	
Nominal energy efficiency (η_g)		%	189 (194)	137 (140)	177 (180)	130 (132)	165 (167)	125 (127)	
Nominal energy class		-	A+++	A++	A+++	A++	A++	A++	
Data for Packaged Fiche:									
Energy efficiency with OTC control (η_g) (*)		%	191 (196)	139 (142)	179 (182)	132 (134)	167 (169)	127 (129)	
Energy class with OTC control		-	A+++	A++	A+++	A++	A++	A++	
Energy efficiency with thermostats/sensors (η_g) (*)		%	193 (198)	141 (144)	181 (184)	134 (136)	169 (171)	129 (131)	
Energy class with thermostats		-	A+++	A++	A+++	A++	A++	A++	
Supplementary capacity (P_{SUP})		kW	0.0	0.9	0.3	1.1	0.6	1.5	
Type of energy used		-	Electricity						
Declared capacity (Pdh) and coefficient of performance (COP _d) at partial load under the following outdoor temperatures:									
Outdoor temperature (T _j) = -7°C	Pdh	kW	3.54	3.50	4.95	4.42	5.90	5.10	
	COP _d	-	3.20	2.30	2.70	1.85	2.50	1.84	
Outdoor temperature (T _j) = +2°C	Pdh	kW	2.15	2.10	3.01	2.69	3.59	3.10	
	COP _d	-	5.20	3.73	4.60	3.45	4.40	3.20	
Outdoor temperature (T _j) = +7°C	Pdh	kW	1.70	1.60	1.90	1.84	2.31	2.00	
	COP _d	-	6.05	4.40	6.00	4.20	5.35	4.45	
Outdoor temperature (T _j) = +12°C	Pdh	kW	1.75	1.60	1.80	2.06	2.10	2.30	
	COP _d	-	6.25	5.00	7.20	6.90	6.15	5.96	
Outdoor temperature (T _j) = Bivalent temperature (T _{biv})	Pdh	kW	3.54	3.50	4.95	4.42	5.90	5.10	
	COP _d	-	3.20	2.30	2.70	1.85	2.50	1.84	
Outdoor temperature (T _j) = Limit operation temperature (TOL)	Pdh	kW	4.00	3.10	5.30	3.90	6.40	4.30	
	COP _d	-	2.75	1.90	2.50	1.80	2.30	1.65	
Bivalent temperature (T _{biv})		°C	-7	-7	-7	-7	-7	-7	
Limit operation temperature (TOL)		°C	-10	-10	-10	-15	-10	-15	
Water limit operation temperature (WTOL)		°C	55	55	55	55	55	55	
Degradation coefficient (Cdh)		-	0.9	0.9	0.9	0.9	0.9	0.9	
Annual energy consumption (Q _{HE})		kW·h	1719 (1675)	2358 (2314)	2569 (2525)	3114 (3070)	3286 (3242)	3724 (3690)	

RAS-(4-6)WHVNPE + RWM-(4.0-6.0)NE

Model		Outdoor unit	RAS-4WHVNPE		RAS-5WHVNPE		RAS-6WHVNPE	
		Indoor unit	RWM-4.0NE		RWM-5.0NE		RWM-6.0NE	
Water outlet temperature			35°C	55°C	35°C	55°C	35°C	55°C
Product description	Air to water heat pump	-	Yes					
	Heat pump combination heater	-	No					
	Low temperature heat pump	-	No					
	Complementary heater	-	Yes					
Design capacity (P_{DESIGN})		kW	11.0	10.0	14.0	12.0	16.0	14.0
Nominal energy efficiency (η_s)		%	187 (189)	136 (137)	175 (176)	133 (134)	153 (153)	125 (126)
Nominal energy class		-	A+++	A++	A+++	A++	A++	A++
Data for Packaged Fiche:								
Energy efficiency with OTC control (η_s) (*)		%	189 (191)	138 (139)	177 (178)	135 (136)	155 (155)	127 (128)
Energy class with OTC control		-	A+++	A++	A+++	A++	A++	A++
Energy efficiency with thermostats/sensors (η_s) (*)		%	191 (193)	140 (141)	179 (180)	137 (138)	157 (157)	129 (130)
Energy class with thermostats		-	A+++	A++	A+++	A++	A++	A++
Supplementary capacity (P_{SUP})		kW	0.5	2.3	1.9	2.6	1.9	3.1
Type of energy used		-	Electricity					
Declared capacity (P_{dh}) and coefficient of performance (COP_d) at partial load under the following outdoor temperatures:								
Outdoor temperature (T_j) = -7°C	P_{dh}	kW	9.60	8.60	12.00	10.25	13.80	11.20
	COP_d	-	2.74	1.80	2.55	1.70	2.40	1.60
Outdoor temperature (T_j) = +2°C	P_{dh}	kW	5.84	5.23	7.30	6.24	8.40	6.82
	COP_d	-	5.20	3.60	4.70	3.60	3.90	3.35
Outdoor temperature (T_j) = +7°C	P_{dh}	kW	3.76	3.52	4.70	4.01	5.40	4.38
	COP_d	-	5.80	4.80	5.70	4.60	5.00	4.35
Outdoor temperature (T_j) = +12°C	P_{dh}	kW	3.70	3.60	3.50	3.50	3.50	3.60
	COP_d	-	6.40	5.80	6.00	5.50	6.00	5.50
Outdoor temperature (T_j) = Bivalent temperature (T_{biv})	P_{dh}	kW	9.60	8.60	12.00	10.25	13.80	11.20
	COP_d	-	2.74	1.80	2.55	1.70	2.40	1.60
Outdoor temperature (T_j) = Limit operation temperature (TOL)	P_{dh}	kW	10.50	7.40	12.10	9.00	14.10	10.5
	COP_d	-	2.65	1.70	2.50	1.60	2.30	1.40
Bivalent temperature (T_{biv})		°C	-7	-7	-7	-7	-7	-7
Limit operation temperature (TOL)		°C	-10	-10	-10	-10	-10	-10
Water limit operation temperature (WTOL)		°C	55	55	55	55	55	55
Degradation coefficient (Cdh)		-	0.9	0.9	0.9	0.9	0.9	0.9
Annual energy consumption (Q_{HE})		kW·h	4714 (4666)	5815 (5767)	6313 (6265)	7066 (7018)	8287 (8239)	8780 (8732)

RAS-(4-6)WHNPE + RWM-(4.0-6.0)NE

Model		Outdoor unit	RAS-4WHNPE		RAS-5WHNPE		RAS-6WHNPE	
		Indoor unit	RWM-4.0NE		RWM-5.0NE		RWM-6.0NE	
Water outlet temperature			35°C	55°C	35°C	55°C	35°C	55°C
Product description	Air to water heat pump	-	Yes					
	Heat pump combination heater	-	No					
	Low temperature heat pump	-	No					
	Complementary heater	-	Yes					
Design capacity (P_{DESIGN})		kW	11.0	10.0	14.0	12.0	16.0	14.0
Nominal energy efficiency (η_s)		%	186(189)	135(137)	174(176)	133(134)	152(153)	125(126)
Nominal energy class		-	A+++	A++	A++ (A+++)	A++	A++	A++
Data for Packaged Fiche:								
Energy efficiency with OTC control (η_s) (*)		%	188(191)	137(139)	176(178)	135(136)	154(155)	127(128)
Energy class with OTC control		-	A+++	A++	A+++	A++	A++	A++
Energy efficiency with thermostats/sensors (η_s) (*)		%	190(193)	139(141)	178(180)	137(138)	156(157)	129(130)
Energy class with thermostats		-	A+++	A++	A+++	A++	A++	A++
Supplementary capacity (P_{SUP})		kW	0.5	2.3	1.9	2.6	1.9	3.1
Type of energy used		-	Electricity					
Declared capacity (P_{dh}) and coefficient of performance (COP_d) at partial load under the following outdoor temperatures:								
Outdoor temperature (T_j) = -7°C	P_{dh}	kW	9.60	8.60	12.00	10.25	13.80	11.20
	COP_d	-	2.74	1.80	2.55	1.70	2.40	1.60
Outdoor temperature (T_j) = +2°C	P_{dh}	kW	5.84	5.23	7.30	6.24	8.40	6.82
	COP_d	-	5.20	3.60	4.70	3.60	3.90	3.35
Outdoor temperature (T_j) = +7°C	P_{dh}	kW	3.76	3.52	4.70	4.01	5.40	4.38
	COP_d	-	5.80	4.80	5.70	4.60	5.00	4.35
Outdoor temperature (T_j) = +12°C	P_{dh}	kW	3.70	3.60	3.50	3.50	3.50	3.60
	COP_d	-	6.40	5.80	6.00	5.50	6.00	5.50
Outdoor temperature (T_j) = Bivalent temperature (T_{biv})	P_{dh}	kW	9.60	8.60	12.00	10.25	13.80	11.20
	COP_d	-	2.74	1.80	2.55	1.70	2.40	1.60
Outdoor temperature (T_j) = Limit operation temperature (TOL)	P_{dh}	kW	10.50	7.40	12.10	9.00	14.10	10.50
	COP_d	-	2.65	1.70	2.50	1.60	2.30	1.40
Bivalent temperature (T_{biv})		°C	-7	-7	-7	-7	-7	-7
Limit operation temperature (TOL)		°C	-10	-10	-10	-10	-10	-10
Water limit operation temperature (WTOL)		°C	55	55	55	55	55	55
Degradation coefficient (Cdh)		-	0.9	0.9	0.9	0.9	0.9	0.9
Annual energy consumption (Q_{HE})		kW·h	4736 (4666)	5837(5767)	6335 (6265)	7088 (7018)	8309 (8239)	8802 (8732)

RAS-(8/10)WHNPE + RWM-(8.0/10.0)NE

Model		Outdoor unit	RAS-8WHNPE		RAS-10WHNPE	
		Indoor unit	RWM-8.0NE		RWM-10.0NE	
Water outlet temperature			35°C	55°C	35°C	55°C
Product description	Air to water heat pump	-	Yes			
	Heat pump combination heater	-	No			
	Low temperature heat pump	-	No			
	Complementary heater	-	Yes			
Design capacity (P_{DESIGN})		kW	18.0	16.0	20.0	18.0
Nominal energy efficiency (η_g)		%	150 (152)	120 (122)	141 (142)	116 (118)
Nominal energy class		-	A++	A+	A+	A+
Data for Packaged Fiche:						
Energy efficiency with OTC control (η_g) (*)		%	152 (154)	122 (124)	143 (144)	118 (120)
Energy class with OTC control		-	A++	A+	A+	A+
Energy efficiency with thermostats/sensors (η_g) (*)		%	154 (156)	124(126)	145 (146)	120 (122)
Energy class with thermostats		-	A++	A+ (A++)	A+	A+
Supplementary capacity (P_{SUP})		kW	1.6	3.5	1.7	3.6
Type of energy used		-	Electricity			
Declared capacity (P_{dh}) and coefficient of performance (COP_d) at partial load under the following outdoor temperatures:						
Outdoor temperature (T_j) = -7°C	P_{dh}	kW	15.60	13.80	17.40	15.60
	COP_d	-	2.50	1.65	2.30	1.65
Outdoor temperature (T_j) = +2°C	P_{dh}	kW	9.50	8.40	10.77	9.50
	COP_d	-	3.85	3.20	3.60	3.10
Outdoor temperature (T_j) = +7°C	P_{dh}	kW	6.10	6.00	8.70	8.30
	COP_d	-	5.40	4.50	5.10	4.35
Outdoor temperature (T_j) = +12°C	P_{dh}	kW	7.00	6.80	8.70	8.50
	COP_d	-	4.65	4.50	4.90	4.60
Outdoor temperature (T_j) = Bivalent temperature (T_{biv})	P_{dh}	kW	15.60	13.80	17.40	15.60
	COP_d	-	2.50	1.65	2.10	1.65
Outdoor temperature (T_j) = Limit operation temperature (TOL)	P_{dh}	kW	16.00	12.10	18.00	14.00
	COP_d	-	2.40	1.50	2.30	1.45
Bivalent temperature (T_{biv})		°C	-7	-7	-7	-7
Limit operation temperature (TOL)		°C	-10	-10	-10	-10
Water limit operation temperature (WTOL)		°C	55	55	55	55
Degradation coefficient (Cdh)		-	0.9	0.9	0.9	0.9
Annual energy consumption (Q_{HE})		kW-h	9513 (9382)	10452 (10320)	11410 (11278)	12210 (12078)

◆ WARMER climate

RAS-(2-3)WHVNP + RWM-(2.0-3.0)NE

Model	Outdoor unit		RAS-2WHVNP	RAS-2.5WHVNP	RAS-3WHVNP
	Indoor unit		RWM-2.0NE	RWM-2.5NE	RWM-3.0NE
Design capacity (P_{DESIGN})	kW		4	5	6
⁽¹⁾ Nominal energy efficiency (η_s)	%		179	172	165
Data for Packaged Fiche:					
⁽²⁾ Energy efficiency with OTC control (η_s) (*)	%		181	174	167
⁽³⁾ Energy efficiency with thermostats (η_s) (*)	%		183	176	169
Annual energy consumption (Q_{HE})	kW·h		1174	1530	1904

RAS-(4-6)WH(V)NPE + RWM-(4.0-6.0)NE

Model	Outdoor unit		RAS-4WHVNP	RAS-5WHVNP	RAS-6WHVNP
	Indoor unit		RWM-4.0NE	RWM-5.0NE	RWM-6.0NE
Design capacity (P_{DESIGN})	kW		10	12	14
⁽¹⁾ Nominal energy efficiency (η_s)	%		193	183	177
Data for Packaged Fiche:					
⁽²⁾ Energy efficiency with OTC control (η_s) (*)	%		195	185	179
⁽³⁾ Energy efficiency with thermostats (η_s) (*)	%		197	187	181
Annual energy consumption (Q_{HE})	kW·h		3036	3454	4148

Model	Outdoor unit		RAS-4WHNPE	RAS-5WHNPE	RAS-6WHNPE
	Indoor unit		RWM-4.0NE	RWM-5.0NE	RWM-6.0NE
Design capacity (P_{DESIGN})	kW		10	12	14
⁽¹⁾ Nominal energy efficiency (η_s)	%		191	181	176
Data for Packaged Fiche:					
⁽²⁾ Energy efficiency with OTC control (η_s) (*)	%		193	183	178
⁽³⁾ Energy efficiency with thermostats (η_s) (*)	%		195	185	180
Annual energy consumption (Q_{HE})	kW·h		3063	3481	4175

RAS-(8/10)WHNPE + RWM-(8.0/10.0)NE

Model	Outdoor unit		RAS-8WHNPE	RAS-10WHNPE
	Indoor unit		RWM-8.0NE	RWM-10.0NE
Design capacity (P_{DESIGN})	kW		16	18
⁽¹⁾ Nominal energy efficiency (η_s)	%		179	176
Data for Packaged Fiche:				
⁽²⁾ Energy efficiency with OTC control (η_s) (*)	%		181	178
⁽³⁾ Energy efficiency with thermostats (η_s) (*)	%		183	180
Annual energy consumption (Q_{HE})	kW·h		4698	5365

◆ COLDER climate

RAS-(2-3)WHVNP + RWM-(2.0-3.0)NE

Model	Outdoor unit		RAS-2WHVNP	RAS-2.5WHVNP	RAS-3WHVNP
	Indoor unit		RWM-2.0NE	RWM-2.5NE	RWM-3.0NE
Design capacity (P_{DESIGN})	kW		4	5	6
⁽¹⁾ Nominal energy efficiency (η_s)	%		125	123	116
Data for Packaged Fiche:					
⁽²⁾ Energy efficiency with OTC control (η_s) (*)	%		127	125	118
⁽³⁾ Energy efficiency with thermostats (η_s) (*)	%		129	127	120
Annual energy consumption (Q_{HE})	kW·h		3017	4022	4980

RAS-(4-6)WH(V)NPE + RWM-(4.0-6.0)NE

Model	Outdoor unit		RAS-4WHVNP	RAS-5WHVNP	RAS-6WHVNP
	Indoor unit		RWM-4.0NE	RWM-5.0NE	RWM-6.0NE
Design capacity (P_{DESIGN})	kW		11	12	14
⁽¹⁾ Nominal energy efficiency (η_s)	%		120	119	112
Data for Packaged Fiche:					
⁽²⁾ Energy efficiency with OTC control (η_s) (*)	%		122	121	114
⁽³⁾ Energy efficiency with thermostats (η_s) (*)	%		124	123	116
Annual energy consumption (Q_{HE})	kW·h		8640	9514	11620

Model	Outdoor unit		RAS-4WHNPE	RAS-5WHNPE	RAS-6WHNPE
	Indoor unit		RWM-4.0NE	RWM-5.0NE	RWM-6.0NE
Design capacity (P_{DESIGN})	kW		11	12	14
⁽¹⁾ Nominal energy efficiency (η_s)	%		120	119	112
Data for Packaged Fiche:					
⁽²⁾ Energy efficiency with OTC control (η_s) (*)	%		122	121	114
⁽³⁾ Energy efficiency with thermostats (η_s) (*)	%		124	123	116
Annual energy consumption (Q_{HE})	kW·h		8654	9528	11633

RAS-(8/10)WHNPE + RWM-(8.0/10.0)NE

Model	Outdoor unit		RAS-8WHNPE	RAS-10WHNPE
	Indoor unit		RWM-8.0NE	RWM-10.0NE
Design capacity (P_{DESIGN})	kW		16	18
⁽¹⁾ Nominal energy efficiency (η_s)	%		109	107
Data for Packaged Fiche:				
⁽²⁾ Energy efficiency with OTC control (η_s) (*)	%		111	109
⁽³⁾ Energy efficiency with thermostats (η_s) (*)	%		113	111
Annual energy consumption (Q_{HE})	kW·h		13974	15905

3.2.2.2 ERP data - YUTAKI S COMBI

◆ AVERAGE climate

RAS-(2-3)WHVNP + RWD-(2.0-3.0)NW(S)E-(200/260)S(-K)

Model		Outdoor unit	RAS-2WHVNP		RAS-2.5WHVNP		RAS-3WHVNP	
		Indoor unit	RWD-2.0NW(S)E-(200/260)S(-K)		RWD-2.5NW(S)E-(200/260)S(-K)		RWD-3.0NW(S)E-(200/260)S(-K)	
Water outlet temperature			35°C	55°C	35°C	55°C	35°C	55°
Product description	Air to water heat pump	-	Yes					
	Heat pump combination heater	-	No					
	Low temperature heat pump	-	No					
	Complementary heater	-	Yes					
Design capacity (P_{DESIGN})		kW	4.0	4.0	6.0	5.0	7.0	6.0
Nominal energy efficiency (η_s)		%	189 (194)	137 (140)	177 (180)	130 (132)	165 (167)	125 (127)
Nominal energy class		-	A+++	A++	A+++	A++	A++	A++
Data for Packaged Fiche:								
Energy efficiency with OTC control (η_s) (*)		%	191 (196)	139 (142)	179 (182)	132 (134)	167 (169)	127 (129)
Energy class with OTC control		-	A+++	A++	A+++	A++	A++	A++
Energy efficiency with thermostats/sensors (η_s) (*)		%	193 (198)	141 (144)	181 (184)	134 (136)	169 (171)	129 (131)
Energy class with thermostats		-	A+++	A++	A+++	A++	A++	A++
Supplementary capacity (P_{SUP})		kW	0.0	0.9	0.3	1.1	0.6	1.5
Type of energy used		-	Electricity					
Declared capacity (P_{dh}) and coefficient of performance (COP_d) at partial load under the following outdoor temperatures:								
Outdoor temperature (T_j) = -7°C	P_{dh}	kW	3.54	3.50	4.95	4.42	5.90	5.10
	COP_d	-	3.20	2.30	2.70	1.85	2.50	1.84
Outdoor temperature (T_j) = +2°C	P_{dh}	kW	2.15	2.10	3.01	2.69	3.59	3.10
	COP_d	-	5.20	3.73	4.60	3.45	4.40	3.20
Outdoor temperature (T_j) = +7°C	P_{dh}	kW	1.70	1.60	1.90	1.84	2.31	2.00
	COP_d	-	6.05	4.40	6.00	4.20	5.35	4.45
Outdoor temperature (T_j) = +12°C	P_{dh}	kW	1.75	1.60	1.80	2.06	2.10	2.30
	COP_d	-	6.25	5.00	7.20	6.90	6.15	5.96
Outdoor temperature (T_j) = Bivalent temperature (T_{biv})	P_{dh}	kW	3.54	3.50	4.95	4.42	5.90	5.10
	COP_d	-	3.20	2.30	2.70	1.85	2.50	1.84
Outdoor temperature (T_j) = Limit operation temperature (TOL)	P_{dh}	kW	4.00	3.10	5.30	3.90	6.40	4.30
	COP_d	-	2.75	1.90	2.50	1.80	2.30	1.65
Bivalent temperature (T_{biv})		°C	-7	-7	-7	-7	-7	-7
Limit operation temperature (TOL)		°C	-10	-10	-10	-15	-10	-15
Water limit operation temperature (WTOL)		°C	55	55	55	55	55	55
Degradation coefficient (Cdh)		-	0.9	0.9	0.9	0.9	0.9	0.9
Annual energy consumption (Q_{HE})		kW·h	1719 (1675)	2358 (2314)	2569 (2525)	3114 (3070)	3286 (3242)	3724 (3690)

RAS-(4-6)WHVNPE + RWD-(4.0-6.0)NW(S)E-(200/260)S(-K)

Model		Outdoor unit	RAS-4WHVNPE		RAS-5WHVNPE		RAS-6WHVNPE	
		Indoor unit	RWD-4.0NW(S)E-(200/260)S(-K)		RWD-5.0NW(S)E-(200/260)S(-K)		RWD-6.0NW(S)E-(200/260)S(-K)	
Water outlet temperature			35°C	55°C	35°C	55°C	35°C	55°
Product description	Air to water heat pump	-	Yes					
	Heat pump combination heater	-	No					
	Low temperature heat pump	-	No					
	Complementary heater	-	Yes					
Design capacity (P_{DESIGN})		kW	11.0	10.0	14.0	12.0	16.0	14.0
Nominal energy efficiency (η_s)		%	187 (189)	136 (137)	175 (176)	133 (134)	153 (153)	125 (126)
Nominal energy class		-	A+++	A++	A+++	A++	A++	A++
Data for Packaged Fiche:								
Energy efficiency with OTC control (η_s) (*)		%	189 (191)	138 (139)	177 (178)	135 (136)	155 (155)	127 (128)
Energy class with OTC control		-	A+++	A++	A+++	A++	A++	A++
Energy efficiency with thermostats/sensors (η_s) (*)		%	191 (193)	140 (141)	179 (180)	137 (138)	157 (157)	129 (130)
Energy class with thermostats		-	A+++	A++	A+++	A++	A++	A++
Supplementary capacity (P_{SUP})		kW	0.5	2.3	1.9	2.6	1.9	3.1
Type of energy used		-	Electricity					
Declared capacity (P_{dh}) and coefficient of performance (COP_d) at partial load under the following outdoor temperatures:								
Outdoor temperature (T_j) = -7°C	P_{dh}	kW	9.60	8.60	12.00	10.25	13.80	11.20
	COP_d	-	2.74	1.80	2.55	1.70	2.40	1.60
Outdoor temperature (T_j) = +2°C	P_{dh}	kW	5.84	5.23	7.30	6.24	8.40	6.82
	COP_d	-	5.20	3.60	4.70	3.60	3.90	3.35
Outdoor temperature (T_j) = +7°C	P_{dh}	kW	3.76	3.52	4.70	4.01	5.40	4.38
	COP_d	-	5.80	4.80	5.70	4.60	5.00	4.35
Outdoor temperature (T_j) = +12°C	P_{dh}	kW	3.70	3.60	3.50	3.50	3.50	3.60
	COP_d	-	6.40	5.80	6.00	5.50	6.00	5.50
Outdoor temperature (T_j) = Bivalent temperature (T_{biv})	P_{dh}	kW	9.60	8.60	12.00	10.25	13.80	11.20
	COP_d	-	2.74	1.80	2.55	1.70	2.40	1.60
Outdoor temperature (T_j) = Limit operation temperature (TOL)	P_{dh}	kW	10.50	7.40	12.10	9.00	14.10	10.5
	COP_d	-	2.65	1.70	2.50	1.60	2.30	1.40
Bivalent temperature (T_{biv})		°C	-7	-7	-7	-7	-7	-7
Limit operation temperature (TOL)		°C	-10	-10	-10	-10	-10	-10
Water limit operation temperature (WTOL)		°C	55	55	55	55	55	55
Degradation coefficient (Cdh)		-	0.9	0.9	0.9	0.9	0.9	0.9
Annual energy consumption (Q_{HE})		kW·h	4714 (4666)	5815 (5767)	6313 (6265)	7066 (7018)	8287 (8239)	8780 (8732)

RAS-(4-6)WHNPE + RWD-(4.0-6.0)NW(S)E-(200/260)S(-K)

Model		Outdoor unit	RAS-4WHNPE		RAS-5WHNPE		RAS-6WHNPE	
		Indoor unit	RWD-4.0NW(S)E-(200/260)S(-K)		RWD-5.0NW(S)E-(200/260)S(-K)		RWD-6.0NW(S)E-(200/260)S(-K)	
Water outlet temperature			35°C	55°C	35°C	55°C	35°C	55°
Product description	Air to water heat pump	-	Yes					
	Heat pump combination heater	-	No					
	Low temperature heat pump	-	No					
	Complementary heater	-	Yes					
Design capacity (P_{DESIGN})		kW	11.0	10.0	14.0	12.0	16.0	14.0
Nominal energy efficiency (η_s)		%	186(189)	135(137)	174(176)	133(134)	152(153)	125(126)
Nominal energy class		-	A+++	A++	A++ (A+++)	A++	A++	A++
Data for Packaged Fiche:								
Energy efficiency with OTC control (η_s) (*)		%	188(191)	137(139)	176(178)	135(136)	154(155)	127(128)
Energy class with OTC control		-	A+++	A++	A+++	A++	A++	A++
Energy efficiency with thermostats/sensors (η_s) (*)		%	190(193)	139(141)	178(180)	137(138)	156(157)	129(130)
Energy class with thermostats		-	A+++	A++	A+++	A++	A++	A++
Supplementary capacity (P_{SUP})		kW	0.5	2.3	1.9	2.6	1.9	3.1
Type of energy used		-	Electricity					
Declared capacity (P_{dh}) and coefficient of performance (COP_d) at partial load under the following outdoor temperatures:								
Outdoor temperature (T_j) = -7°C	Pdh	kW	9.60	8.60	12.00	10.25	13.80	11.20
	COP_d	-	2.74	1.80	2.55	1.70	2.40	1.60
Outdoor temperature (T_j) = +2°C	Pdh	kW	5.84	5.23	7.30	6.24	8.40	6.82
	COP_d	-	5.20	3.60	4.70	3.60	3.90	3.35
Outdoor temperature (T_j) = +7°C	Pdh	kW	3.76	3.52	4.70	4.01	5.40	4.38
	COP_d	-	5.80	4.80	5.70	4.60	5.00	4.35
Outdoor temperature (T_j) = +12°C	Pdh	kW	3.70	3.60	3.50	3.50	3.50	3.60
	COP_d	-	6.40	5.80	6.00	5.50	6.00	5.50
Outdoor temperature (T_j) = Bivalent temperature (T_{biv})	Pdh	kW	9.60	8.60	12.00	10.25	13.80	11.20
	COP_d	-	2.74	1.80	2.55	1.70	2.40	1.60
Outdoor temperature (T_j) = Limit operation temperature (TOL)	Pdh	kW	10.50	7.40	12.10	9.00	14.10	10.50
	COP_d	-	2.65	1.70	2.50	1.60	2.30	1.40
Bivalent temperature (T_{biv})		°C	-7	-7	-7	-7	-7	-7
Limit operation temperature (TOL)		°C	-10	-10	-10	-10	-10	-10
Water limit operation temperature (WTOL)		°C	55	55	55	55	55	55
Degradation coefficient (Cdh)		-	0.9	0.9	0.9	0.9	0.9	0.9
Annual energy consumption (Q_{HE})		kW·h	4736 (4666)	5837(5767)	6335 (6265)	7088 (7018)	8309 (8239)	8802 (8732)

◆ WARMER climate

RAS-(2-3)WHVNP + RWD-(2.0-3.0)NW(S)E-(200/260)S(-K)

Model	Outdoor unit		RAS-2WHVNP	RAS-2.5WHVNP	RAS-3WHVNP
	Indoor unit		RWD-2.0NW(S)E-(200/260)S(-K)	RWD-2.5NW(S)E-(200/260)S(-K)	RWD-3.0NW(S)E-(200/260)S(-K)
Design capacity (P_{DESIGN})	kW		4	5	6
⁽¹⁾ Nominal energy efficiency (η_s)	%		179	172	165
Data for Packaged Fiche:					
⁽²⁾ Energy efficiency with OTC control (η_s) (*)	%		181	175	167
⁽³⁾ Energy efficiency with thermostats (η_s) (*)	%		183	177	169
Annual energy consumption (Q_{HE})	kW·h		1174	1530	1904

RAS-(4-6)WH(V)NPE + RWD-(4.0-6.0)NW(S)E-(200/260)S(-K)

Model	Outdoor unit		RAS-4WHVNP	RAS-5WHVNP	RAS-6WHVNP
	Indoor unit		RWD-4.0NW(S)E-(200/260)S(-K)	RWD-5.0NW(S)E-(200/260)S(-K)	RWD-6.0NW(S)E-(200/260)S(-K)
Design capacity (P_{DESIGN})	kW		10	12	14
⁽¹⁾ Nominal energy efficiency (η_s)	%		193	183	177
Data for Packaged Fiche:					
⁽²⁾ Energy efficiency with OTC control (η_s) (*)	%		195	185	179
⁽³⁾ Energy efficiency with thermostats (η_s) (*)	%		197	187	181
Annual energy consumption (Q_{HE})	kW·h		3036	3454	4148

Model	Outdoor unit		RAS-4WHNPE	RAS-5WHNPE	RAS-6WHNPE
	Indoor unit		RWD-4.0NW(S)E-(200/260)S(-K)	RWD-5.0NW(S)E-(200/260)S(-K)	RWD-6.0NW(S)E-(200/260)S(-K)
Design capacity (P_{DESIGN})	kW		10	12	14
⁽¹⁾ Nominal energy efficiency (η_s)	%		191	181	176
Data for Packaged Fiche:					
⁽²⁾ Energy efficiency with OTC control (η_s) (*)	%		193	183	178
⁽³⁾ Energy efficiency with thermostats (η_s) (*)	%		195	185	180
Annual energy consumption (Q_{HE})	kW·h		3063	3481	4175

◆ COLDER climate

RAS-(2-3)WHVNP + RWD-(2.0-3.0)NW(S)E-(200/260)S(-K)

Model	Outdoor unit		RAS-2WHVNP	RAS-2.5WHVNP	RAS-3WHVNP
	Indoor unit		RWD-2.0NW(S)E-(200/260)S(-K)	RWD-2.5NW(S)E-(200/260)S(-K)	RWD-3.0NW(S)E-(200/260)S(-K)
Design capacity (P_{DESIGN})	kW		4	5	6
⁽¹⁾ Nominal energy efficiency (η_s)	%		125	123	116
Data for Packaged Fiche:					
⁽²⁾ Energy efficiency with OTC control (η_s) (*)	%		127	125	118
⁽³⁾ Energy efficiency with thermostats (η_s) (*)	%		129	127	120
Annual energy consumption (Q_{HE})	kW-h		3017	4022	4980

RAS-(4-6)WH(V)NPE + RWD-(4.0-6.0)NW(S)E-(200/260)S(-K)

Model	Outdoor unit		RAS-4WHVNPE	RAS-5WHVNPE	RAS-6WHVNPE
	Indoor unit		RWD-4.0NW(S)E-(200/260)S(-K)	RWD-5.0NW(S)E-(200/260)S(-K)	RWD-6.0NW(S)E-(200/260)S(-K)
Design capacity (P_{DESIGN})	kW		11	12	14
⁽¹⁾ Nominal energy efficiency (η_s)	%		120	119	112
Data for Packaged Fiche:					
⁽²⁾ Energy efficiency with OTC control (η_s) (*)	%		122	121	114
⁽³⁾ Energy efficiency with thermostats (η_s) (*)	%		124	123	116
Annual energy consumption (Q_{HE})	kW-h		8640	9514	11620

Model	Outdoor unit		RAS-4WHNPE	RAS-5WHNPE	RAS-6WHNPE
	Indoor unit		RWD-4.0NW(S)E-(200/260)S(-K)	RWD-5.0NW(S)E-(200/260)S(-K)	RWD-6.0NW(S)E-(200/260)S(-K)
Design capacity (P_{DESIGN})	kW		11	12	14
⁽¹⁾ Nominal energy efficiency (η_s)	%		120	119	112
Data for Packaged Fiche:					
⁽²⁾ Energy efficiency with OTC control (η_s) (*)	%		122	121	114
⁽³⁾ Energy efficiency with thermostats (η_s) (*)	%		124	123	116
Annual energy consumption (Q_{HE})	kW-h		8654	9528	11633

3.2.2.3 ERP data - YUTAKI S80

◆ AVERAGE climate

RAS-(4-6)WHVNPE + RWH-(4.0-6.0)VNF(W)E

Model		Outdoor unit	RAS-4WHVNPE		RAS-5WHVNPE		RAS-6WHVNPE	
		Indoor unit	RWH-4.0VNF(W)E		RWH-5.0VNF(W)E		RWH-6.0VNF(W)E	
Water outlet temperature			35°C	55°C	35°C	55°C	35°C	55°C
Product description	Air to water heat pump	-	Yes					
	Heat pump combination heater	-	No					
	Low temperature heat pump	-	No					
	Complementary heater	-	No					
Design capacity (P_{DESIGN})		kW	11.0	11.0	14.0	14.0	16.0	16.0
Nominal energy efficiency (η_s)		%	187	142	174	131	152	126
Nominal energy class		-	A+++	A++	A++	A++	A++	A++
Data for Packaged Fiche:								
Energy efficiency with OTC control (η_s) (*)		%	189	144	176	133	154	128
Energy class with OTC control		-	A+++	A++	A+++	A++	A++	A++
Energy efficiency with thermostats (η_s) (*)		%	191	146	178	135	156	130
Energy class with thermostats		-	A+++	A++	A+++	A++	A++	A++
Supplementary capacity (P_{SUP})		kW	0.5	0.0	1.9	0.0	1.9	0.0
Type of energy used		-	Electricity					
Declared capacity (P_{dh}) and coefficient of performance (COP_d) at partial load under the following outdoor temperatures:								
Outdoor temperature (T_j) = -7°C	P_{dh}	kW	9.60	9.73	12.00	12.38	13.80	14.15
	COP_d	-	2.74	2.30	2.55	2.19	2.40	2.05
Outdoor temperature (T_j) = +2°C	P_{dh}	kW	5.84	5.92	7.30	7.54	8.40	8.62
	COP_d	-	5.20	3.60	4.70	3.10	3.90	2.95
Outdoor temperature (T_j) = +7°C	P_{dh}	kW	3.76	3.81	4.70	4.85	5.40	5.54
	COP_d	-	5.80	4.70	5.70	4.60	5.00	4.60
Outdoor temperature (T_j) = +12°C	P_{dh}	kW	3.70	3.60	3.50	4.10	3.50	4.10
	COP_d	-	6.40	6.00	6.00	6.40	6.00	6.40
Outdoor temperature (T_j) = Bivalent temperature (T_{biv})	P_{dh}	kW	9.60	11.00	12.00	14.00	13.80	16.00
	COP_d	-	2.74	2.20	2.55	2.12	2.40	1.90
Outdoor temperature (T_j) = Limit operation temperature (T_{ol})	P_{dh}	kW	10.50	11.00	12.10	14.00	14.10	16.00
	COP_d	-	2.65	2.20	2.50	1.40	2.30	1.50
Bivalent temperature (T_{biv})		°C	-7	-10	-7	-10	-7	-10
Limit operation temperature (TOL)		°C	-10	-10	-10	-10	-10	-10
Water limit operation temperature (WTOL)		°C	55	55	55	55	55	55
Degradation coefficient (Cdh)		-	0.9	0.9	0.9	0.9	0.9	0.9
Annual energy consumption (Q_{HE})		kW·h	4732	6261	6330	8648	8304	10255

RAS-(4-6)WHNPE + RWH-(4.0-6.0)NF(W)E

Model		Outdoor unit	RAS-4WHNPE		RAS-5WHNPE		RAS-6WHNPE	
		Indoor unit	RWH-4.0NF(W)E		RWH-5.0NF(W)E		RWH-6.0NF(W)E	
Water outlet temperature			35°C	55°C	35°C	55°C	35°C	55°C
Product description	Air to water heat pump	-	Yes					
	Heat pump combination heater	-	No					
	Low temperature heat pump	-	No					
	Complementary heater	-	No					
Design capacity (P _{DESIGN})		kW	11.0	11.0	14.0	14.0	16.0	16.0
Nominal energy efficiency (η _s)		%	183	140	171	129	150	125
Nominal energy class		-	A+++	A++	A++	A++	A++	A++
Data for Packaged Fiche:								
Energy efficiency with OTC control (η _s) (*)		%	185	142	173	131	152	127
Energy class with OTC control		-	A+++	A++	A++	A++	A++	A++
Energy efficiency with thermostats (η _s) (*)		%	187	144	176	134	154	129
Energy class with thermostats		-	A+++	A++	A+++	A++	A++	A++
Supplementary capacity (P _{SUP})		kW	0.5	0.0	1.5	0.0	1.5	0.0
Type of energy used		-	Electricity					
Declared capacity (P _{dh}) and coefficient of performance (COP _d) at partial load under the following outdoor temperatures:								
Outdoor temperature (T _j) = -7°C	P _{dh}	kW	9.60	9.73	12.00	12.38	13.80	14.15
	COP _d	-	2.74	2.30	2.55	2.19	2.40	2.05
Outdoor temperature (T _j) = +2°C	P _{dh}	kW	5.84	5.92	7.30	7.54	8.40	8.62
	COP _d	-	5.20	3.60	4.70	3.10	3.90	2.95
Outdoor temperature (T _j) = +7°C	P _{dh}	kW	3.76	3.81	4.70	4.85	5.40	5.54
	COP _d	-	5.80	4.70	5.70	4.60	5.00	4.60
Outdoor temperature (T _j) = +12°C	P _{dh}	kW	3.70	3.60	3.50	4.10	3.50	4.10
	COP _d	-	6.40	6.00	6.00	6.40	6.00	6.40
Outdoor temperature (T _j) = Bivalent temperature (T _{biv})	P _{dh}	kW	9.60	11.00	12.00	14.00	13.80	16.00
	COP _d	-	2.74	2.20	2.55	2.12	2.40	1.90
Outdoor temperature (T _j) = Limit operation temperature (TOL)	P _{dh}	kW	10.50	11.00	12.10	14.00	14.10	16.00
	COP _d	-	2.65	2.20	2.50	1.40	2.30	1.50
Bivalent temperature (T _{biv})		°C	-7	-10	-7	-10	-7	-10
Limit operation temperature (TOL)		°C	-10	-10	-10	-10	-10	-10
Water limit operation temperature (WTOL)		°C	55	55	55	55	55	55
Degradation coefficient (C _{dh})		-	0.9	0.9	0.9	0.9	0.9	0.9
Annual energy consumption (Q _{HE})		kW·h	4828	6360	6426	8747	8401	10335

◆ WARMER climate

RAS-(4-6)WH(V)NPE + RWH-(4.0-6.0)(V)NF(W)E + DHWS(200/260)S-2.0H2E

Model	Outdoor unit	RAS-4WHVNPE	RAS-5WHVNPE	RAS-6WHVNPE
	Indoor unit	RWH-4.0VNF(W)E	RWH-5.0VNF(W)E	RWH-6.0VNF(W)E
	Tank unit (RWH-(V)NFWE)	DHWS(200/260) S-2.0H2E	DHWS(200/260) S-2.0H2E	DHWS(200/260) S-2.0H2E
Design capacity (P_{DESIGN})	kW	11	14	16
⁽¹⁾ Nominal energy efficiency (η_s)	%	188	177	173
Data for Packaged Fiche:				
⁽²⁾ Energy efficiency with OTC control (η_s) (*)	%	190	179	175
⁽³⁾ Energy efficiency with thermostats (η_s) (*)	%	192	181	177
Annual energy consumption (Q_{HE})	kW·h	3070	4156	4866

Model	Outdoor unit	RAS-4WHNPE	RAS-5WHNPE	RAS-6WHNPE
	Indoor unit	RWH-4.0NF(W)E	RWH-5.0NF(W)E	RWH-6.0NF(W)E
	Tank unit (RWH-(V)NFWE)	DHWS(200/260) S-2.0H2E	DHWS(200/260) S-2.0H2E	DHWS(200/260) S-2.0H2E
Design capacity (P_{DESIGN})	kW	11	14	16
⁽¹⁾ Nominal energy efficiency (η_s)	%	181	172	168
Data for Packaged Fiche:				
⁽²⁾ Energy efficiency with OTC control (η_s) (*)	%	183	174	170
⁽³⁾ Energy efficiency with thermostats (η_s) (*)	%	185	176	172
Annual energy consumption (Q_{HE})	kW·h	3190	4276	4986

◆ COLDER climate

RAS-(4-6)WH(V)NPE + RWH-(4.0-6.0)(V)NF(W)E + DHWS(200/260)S-2.0H2E

Model	Outdoor unit	RAS-4WHVNPE	RAS-5WHVNPE	RAS-6WHVNPE
	Indoor unit	RWH-4.0VNF(W)E	RWH-5.0VNF(W)E	RWH-6.0VNF(W)E
	Tank unit (RWH-(V)NFWE)	DHWS(200/260) S-2.0H2E	DHWS(200/260) S-2.0H2E	DHWS(200/260) S-2.0H2E
Design capacity (P_{DESIGN})	kW	13	17	18
⁽¹⁾ Nominal energy efficiency (η_s)	%	126	122	119
Data for Packaged Fiche:				
⁽²⁾ Energy efficiency with OTC control (η_s) (*)	%	128	124	121
⁽³⁾ Energy efficiency with thermostats (η_s) (*)	%	130	126	123
Annual energy consumption (Q_{HE})	kW·h	10292	13558	14860

Model	Outdoor unit	RAS-4WHNPE	RAS-5WHNPE	RAS-6WHNPE
	Indoor unit	RWH-4.0NF(W)E	RWH-5.0NF(W)E	RWH-6.0NF(W)E
	Tank unit (RWH-(V)NFWE)	DHWS(200/260) S-2.0H2E	DHWS(200/260) S-2.0H2E	DHWS(200/260) S-2.0H2E
Design capacity (P_{DESIGN})	kW	13	17	18
⁽¹⁾ Nominal energy efficiency (η_s)	%	125	121	119
Data for Packaged Fiche:				
⁽²⁾ Energy efficiency with OTC control (η_s) (*)	%	127	123	121
⁽³⁾ Energy efficiency with thermostats (η_s) (*)	%	129	125	123
Annual energy consumption (Q_{HE})	kW·h	10352	13619	14920

3.2.2.4 ERP data - YUTAKI M

◆ AVERAGE climate

RASM-(3-6)VNE

Model			RASM-3VNE		RASM-4VNE		RASM-5VNE		RASM-6VNE	
Water outlet temperature			35°C	55°C	35°C	55°C	35°C	55°C	35°C	55°C
Product description	Air to water heat pump	-	Yes							
	Heat pump combination heater	-	No							
	Low temperature heat pump	-	No							
	Complementary heater	-	No							
Design capacity (P_{DESIGN})	kW	7.0	6.0	11.0	10.0	14.0	12.0	16.0	14.0	
Nominal energy efficiency (η_s)	%	164 (167)	125 (127)	187 (189)	136 (137)	175 (176)	133 (134)	153 (153)	125 (126)	
Nominal energy class	-	A++	A++	A+++	A++	A+++	A++	A++	A++	
Data for Packaged Fiche:										
Energy efficiency with OTC control (η_s) (*)	%	166 (169)	127 (129)	189 (191)	138 (139)	177 (178)	135 (136)	155 (155)	127 (128)	
	-	A++	A++	A+++	A++	A+++	A++	A++	A++	
Energy efficiency with thermostats (η_s) (*)	%	168 (171)	129 (131)	191 (193)	140 (141)	179 (180)	137 (138)	157 (157)	129 (130)	
	-	A++	A++	A+++	A++	A+++	A++	A++	A++	
Supplementary capacity (P_{SUP})	kW	0.6	0.6	0.5	1.2	1.9	1.5	1.9	2.3	
Type of energy used	-	Electricity								
Declared capacity (P_{dh}) and coefficient of performance (COP_d) at partial load under the following outdoor temperatures:										
Outdoor temperature (T_j) = -7°C	P_{dh}	kW	5.90	5.10	9.60	8.60	12.00	10.25	13.80	11.20
	COP_d	-	2.50	1.84	2.74	1.80	2.55	1.70	2.40	1.60
Outdoor temperature (T_j) = +2°C	P_{dh}	kW	3.59	3.10	5.84	5.23	7.30	6.24	8.40	6.82
	COP_d	-	4.40	3.20	5.20	3.60	4.70	3.60	3.90	3.35
Outdoor temperature (T_j) = +7°C	P_{dh}	kW	2.31	2.00	3.76	3.52	4.70	4.01	5.40	4.38
	COP_d	-	5.35	4.45	5.80	4.80	5.70	4.60	5.00	4.35
Outdoor temperature (T_j) = +12°C	P_{dh}	kW	2.10	2.30	3.70	3.60	3.50	3.50	3.50	3.60
	COP_d	-	6.15	5.96	6.40	5.80	6.00	5.50	6.00	5.50
Outdoor temperature (T_j) = Bivalent temperature (T_{biv})	P_{dh}	kW	5.90	5.10	9.60	8.60	12.00	10.25	13.80	11.20
	COP_d	-	2.50	1.84	2.74	1.80	2.55	1.70	2.40	1.60
Outdoor temperature (T_j) = Limit operation temperature (TOL)	P_{dh}	kW	6.40	5.20	10.50	8.80	12.10	10.50	14.10	11.70
	COP_d	-	2.30	1.65	2.65	1.90	2.50	1.70	2.30	1.55
Bivalent temperature (T_{biv})	°C	-7	-7	-7	-7	-7	-7	-7	-7	
Limit operation temperature (TOL)	°C	-10	-15	-10	-10	-10	-10	-10	-10	
Water limit operation temperature (WTOL)	°C	55	55	55	55	55	55	55	55	
Degradation coefficient (Cdh)	-	0.9	0.9	0.9	0.9	0.9	0.9	0.9	0.9	
Annual energy consumption (Q_{HE})	kW·h	3298 (3242)	3726 (3671)	4714 (4666)	5786 (5738)	6313 (6265)	7042 (6994)	8287 (8239)	8170 (8122)	

RASM-(4-6)NE

Model			RASM-4NE		RASM-5NE		RASM-6NE	
Water outlet temperature			35°C	55°C	35°C	55°C	35°C	55°C
Product description	Air to water heat pump	-	Yes					
	Heat pump combination heater	-	No					
	Low temperature heat pump	-	No					
	Complementary heater	-	No					
Design capacity (P_{DESIGN})	kW	11.0	10.0	14.0	12.0	16.0	14.0	
Nominal energy efficiency (η_s)	%	186(189)	135(137)	174(176)	133(134)	152(153)	125(126)	
Nominal energy class	-	A+++	A++	A++ (A+++)	A++	A++	A++	
Data for Packaged Fiche:								
	Energy efficiency with OTC control (η_s) (*)	%	188(191)	137(139)	176(178)	135(136)	154(155)	127(128)
	Energy class with OTC control	-	A+++	A++	A+++	A++	A++	A++
	Energy efficiency with thermostats (η_s) (*)	%	190(193)	139(141)	178(180)	137(138)	156(157)	129(130)
	Energy class with thermostats	-	A+++	A++	A+++	A++	A++	A++
Supplementary capacity (P_{SUP})	kW	0.5	1.2	1.9	1.5	1.9	2.3	
Type of energy used	-	Electricity						
Declared capacity (P_{dh}) and coefficient of performance (COP_d) at partial load under the following outdoor temperatures:								
Outdoor temperature (T_j) = -7°C	P_{dh}	kW	9.60	8.60	12.00	10.25	13.80	11.20
	COP_d	-	2.74	1.80	2.55	1.70	2.40	1.60
Outdoor temperature (T_j) = +2°C	P_{dh}	kW	5.84	5.23	7.30	6.24	8.40	6.82
	COP_d	-	5.20	3.60	4.70	3.60	3.90	3.35
Outdoor temperature (T_j) = +7°C	P_{dh}	kW	3.76	3.52	4.70	4.01	5.40	4.38
	COP_d	-	5.80	4.80	5.70	4.60	5.00	4.35
Outdoor temperature (T_j) = +12°C	P_{dh}	kW	3.70	3.60	3.50	3.50	3.50	3.60
	COP_d	-	6.40	5.80	6.00	5.50	6.00	5.50
Outdoor temperature (T_j) = Bivalent temperature (T_{biv})	P_{dh}	kW	9.60	8.60	12.00	10.25	13.80	11.20
	COP_d	-	2.74	1.80	2.55	1.70	2.40	1.60
Outdoor temperature (T_j) = Limit operation temperature (T_{ol})	P_{dh}	kW	10.50	8.80	12.10	10.50	14.10	11.70
	COP_d	-	2.65	1.90	2.50	1.70	2.30	1.55
Bivalent temperature (T_{biv})	°C	-7	-7	-7	-7	-7	-7	
Limit operation temperature (TOL)	°C	-10	-10	-10	-10	-10	-10	
Water limit operation temperature (WTOL)	°C	55	55	55	55	55	55	
Degradation coefficient (C_{dh})	-	0.9	0.9	0.9	0.9	0.9	0.9	
Annual energy consumption (Q_{HE})	kW·h	4736 (4666)	5808 (5738)	6335 (6265)	7064 (6994)	8309 (8239)	8192 (8122)	

◆ WARMER climate

RASM-(3-4)(V)NE

Model	Outdoor unit	RASM-3VNE	RASM-4VNE	RASM-5VNE	RASM-6VNE
Design capacity (P_{DESIGN})	kW	6	10	12	14
⁽¹⁾ Nominal energy efficiency (η_s)	%	164	193	183	177
Data for Packaged Fiche:					
⁽²⁾ Energy efficiency with OTC control (η_s) (*)	%	166	195	185	179
⁽³⁾ Energy efficiency with thermostats (η_s) (*)	%	168	197	187	181
Annual energy consumption (Q_{HE})	kW·h	1919	3036	3454	4148

Model	Outdoor unit	RASM-4NE	RASM-5NE	RASM-6NE
Design capacity (P_{DESIGN})	kW	10	12	14
⁽¹⁾ Nominal energy efficiency (η_s)	%	191	181	176
Data for Packaged Fiche:				
⁽²⁾ Energy efficiency with OTC control (η_s) (*)	%	193	183	178
⁽³⁾ Energy efficiency with thermostats (η_s) (*)	%	195	185	180
Annual energy consumption (Q_{HE})	kW·h	3063	3481	4175

◆ COLDER climate

RASM-(3-4)(V)NE

Model	Outdoor unit	RASM-3VNE	RASM-4VNE	RASM-5VNE	RASM-6VNE
Design capacity (P_{DESIGN})	kW	6	11	12	14
⁽¹⁾ Nominal energy efficiency (η_s)	%	116	120	119	112
Data for Packaged Fiche:					
⁽²⁾ Energy efficiency with OTC control (η_s) (*)	%	118	122	121	114
⁽³⁾ Energy efficiency with thermostats (η_s) (*)	%	120	124	123	116
Annual energy consumption (Q_{HE})	kW·h	4987	8640	9514	11620

Model	Outdoor unit	RASM-4NE	RASM-5NE	RASM-6nE
Design capacity (P_{DESIGN})	kW	11	12	14
⁽¹⁾ Nominal energy efficiency (η_s)	%	120	119	112
Data for Packaged Fiche:				
⁽²⁾ Energy efficiency with OTC control (η_s) (*)	%	122	121	114
⁽³⁾ Energy efficiency with thermostats (η_s) (*)	%	124	123	116
Annual energy consumption (Q_{HE})	kW·h	8654	9528	11633

3.2.2.5 ERP additional data - YUTAKI S

RAS-(2-3)WHVNP + RWM-(2.0-3.0)NE

Model	Outdoor unit	RAS-2WHVNP	RAS-2.5WHVNP	RAS-3WHVNP
	Indoor unit	RWM-2.0NE	RWM-2.5NE	RWM-3.0NE
Electrical power input in stand-by mode (Psb)	W	11.9	11.9	11.9
Electrical power input in thermostat-OFF mode (Pto)	W	0.0	0.0	0.0
Electrical power input in OFF mode (Poff)	W	11.9	11.9	11.9
Electrical power input in crankcase heater mode (Pck)	W	0.0	0.0	0.0
Sound power level of indoor unit (L _{WA})	dB(A)	37	37	37
Sound power level of outdoor unit (L _{WA})	dB(A)	61	63	64
Capacity control mode	-	Variable (Inverter)		
Integrated supplementary heater	kW	3.0	3.0	3.0
Nominal outdoor air flow	m ³ /h	2436	2436	2682

RAS-(4-6)WHVNPE + RWM-(4.0-6.0)NE

Model	Outdoor unit	RAS-4WHVNPE	RAS-5WHVNPE	RAS-6WHVNPE
	Indoor unit	RWM-4.0NE	RWM-5.0NE	RWM-6.0NE
Electrical power input in stand-by mode (Psb)	W	13.1	13.1	13.1
Electrical power input in thermostat-OFF mode (Pto)	W	0.0	0.0	0.0
Electrical power input in OFF mode (Poff)	W	13.1	13.1	13.1
Electrical power input in crankcase heater mode (Pck)	W	0.0	0.0	0.0
Sound power level of indoor unit (L _{WA})	dB(A)	39	39	39
Sound power level of outdoor unit (L _{WA})	dB(A)	64	65	67
Capacity control mode	-	Variable (Inverter)		
Integrated supplementary heater	kW	6.0	6.0	6.0
Nominal outdoor air flow	m ³ /h	4800	5400	6000

RAS-(4-6)WHNPE + RWM-(4.0-6.0)NE

Model	Outdoor unit	RAS-4WHNPE	RAS-5WHNPE	RAS-6WHNPE
	Indoor unit	RWM-4.0NE	RWM-5.0NE	RWM-6.0NE
Electrical power input in stand-by mode (Psb)	W	19.1	19.1	19.1
Electrical power input in thermostat-OFF mode (Pto)	W	0.0	0.0	0.0
Electrical power input in OFF mode (Poff)	W	19.1	19.1	19.1
Electrical power input in crankcase heater mode (Pck)	W	0.0	0.0	0.0
Sound power level of indoor unit (L _{WA})	dB(A)	39	39	39
Sound power level of outdoor unit (L _{WA})	dB(A)	64	65	67
Capacity control mode	-	Variable (Inverter)		
Integrated supplementary heater	kW	6.0	6.0	6.0
Nominal outdoor air flow	m ³ /h	4800	5400	6000

RAS-(8/10)WHNPE + RWM-(8.0/10.0)NE

Model	Outdoor unit	RAS-8WHNPE	RAS-10WHNPE
	Indoor unit	RWM-8.0NE	RWM-10.0NE
Electrical power input in stand-by mode (Psb)	W	36	36
Electrical power input in thermostat-OFF mode (Pto)	W	0.0	0.0
Electrical power input in OFF mode (Poff)	W	36	36
Electrical power input in crankcase heater mode (Pck)	W	0.0	0.0
Sound power level of indoor unit (L _{WA})	dB(A)	47	47
Sound power level of outdoor unit (L _{WA})	dB(A)	73	74
Capacity control mode	-	Variable (Inverter)	
Integrated supplementary heater	kW	9.0	9.0
Nominal outdoor air flow	m ³ /h	7620	8040

3.2.2.6 ERP additional data - YUTAKI S COMBI

RAS-(2-3)WHVNP + RWD-(2.0-3.0)NW(S)E-(200/260)S(-K)

Model	Outdoor unit	RAS-2WHVNP	RAS-2.5WHVNP	RAS-3WHVNP
	Indoor unit	RWD-2.0NW(S)E (200/260)S(-K)	RWD-2.5NW(S)E (200/260)S(-K)	RWD-3.0NW(S)E (200/260)S(-K)
Electrical power input in stand-by mode (Psb)	W	11.9	11.9	11.9
Electrical power input in thermostat-OFF mode (Pto)	W	0.0	0.0	0.0
Electrical power input in OFF mode (Poff)	W	11.9	11.9	11.9
Electrical power input in crankcase heater mode (Pck)	W	0.0	0.0	0.0
Sound power level of indoor unit (L_{WA})	dB(A)	37	37	37
Sound power level of outdoor unit (L_{WA})	dB(A)	61	63	64
Capacity control mode	-	Variable (Inverter)		
Integrated supplementary heater	kW	3.0	3.0	3.0
Nominal outdoor air flow	m ³ /h	2436	2436	2682

RAS-(4-6)WHVNPE + RWD-(4.0-6.0)NW(S)E-(200/260)S(-K)

Model	Outdoor unit	RAS-4WHVNPE	RAS-5WHVNPE	RAS-6WHVNPE
	Indoor unit	RWD-4.0NW(S)E (200/260)S(-K)	RWD-5.0NW(S)E (200/260)S(-K)	RWD-6.0NW(S)E (200/260)S(-K)
Electrical power input in stand-by mode (Psb)	W	13.1	13.1	13.1
Electrical power input in thermostat-OFF mode (Pto)	W	0.0	0.0	0.0
Electrical power input in OFF mode (Poff)	W	13.1	13.1	13.1
Electrical power input in crankcase heater mode (Pck)	W	0.0	0.0	0.0
Sound power level of indoor unit (L_{WA})	dB(A)	39	39	39
Sound power level of outdoor unit (L_{WA})	dB(A)	64	65	67
Capacity control mode	-	Variable (Inverter)		
Integrated supplementary heater	kW	6.0	6.0	6.0
Nominal outdoor air flow	m ³ /h	4800	5400	6000

RAS-(4-6)WHNPE + RWD-(4.0-6.0)NW(S)E-(200/260)S(-K)

Model	Outdoor unit	RAS-4WHNPE	RAS-5WHNPE	RAS-6WHNPE
	Indoor unit	RWD-4.0NW(S)E (200/260)S(-K)	RWD-5.0NW(S)E (200/260)S(-K)	RWD-6.0NW(S)E (200/260)S(-K)
Electrical power input in stand-by mode (Psb)	W	19.1	19.1	19.1
Electrical power input in thermostat-OFF mode (Pto)	W	0.0	0.0	0.0
Electrical power input in OFF mode (Poff)	W	19.1	19.1	19.1
Electrical power input in crankcase heater mode (Pck)	W	0.0	0.0	0.0
Sound power level of indoor unit (L_{WA})	dB(A)	39	39	39
Sound power level of outdoor unit (L_{WA})	dB(A)	64	65	67
Capacity control mode	-	Variable (Inverter)		
Integrated supplementary heater	kW	6.0	6.0	6.0
Nominal outdoor air flow	m ³ /h	4800	5400	6000

3.2.2.7 ERP additional data - YUTAKI S80

RAS-(4-6)WHVNPE + RWH-(4.0-6.0)VNF(W)E

Model	Outdoor unit	RAS-4WHVNPE	RAS-5WHVNPE	RAS-6WHVNPE
	Indoor unit	RWH-4.0VNF(W)E	RWH-5.0VNF(W)E	RWH-6.0VNF(W)E
Electrical power input in stand-by mode (Psb)	W	17.0	17.0	17.0
Electrical power input in thermostat-OFF mode (Pto)	W	0.0	0.0	0.0
Electrical power input in OFF mode (Poff)	W	17.0	17.0	17.0
Electrical power input in crankcase heater mode (Pck)	W	0.0	0.0	0.0
Sound power level of indoor unit (L _{WA})	dB(A)	57	57	58
Sound power level of outdoor unit (L _{WA})	dB(A)	61	63	64
Capacity control mode	-	Variable (Inverter)		
Integrated supplementary heater	kW	No		
Nominal outdoor air flow	m ³ /h	4800	5400	6000

RAS-(4-6)WHNPE + RWH-(4.0-6.0)NF(W)E

Model	Outdoor unit	RAS-4WHNPE	RAS-5WHNPE	RAS-6WHNPE
	Indoor unit	RWH-4.0NF(W)E	RWH-5.0NF(W)E	RWH-6.0NF(W)E
Electrical power input in stand-by mode (Psb)	W	44.0	44.0	44.0
Electrical power input in thermostat-OFF mode (Pto)	W	0.0	0.0	0.0
Electrical power input in OFF mode (Poff)	W	44.0	44.0	44.0
Electrical power input in crankcase heater mode (Pck)	W	0.0	0.0	0.0
Sound power level of indoor unit (L _{WA})	dB(A)	57	57	58
Sound power level of outdoor unit (L _{WA})	dB(A)	61	63	64
Capacity control mode	-	Variable (Inverter)		
Integrated supplementary heater	kW	No		
Nominal outdoor air flow	m ³ /h	4800	5400	6000

3.2.2.8 ERP additional data - YUTAKI M

RASM-(3-6)VNE

Model		RASM-3VNE	RASM-4VNE	RASM-5VNE	RASM-6VNE
Electrical power input in stand-by mode (Psb)	W	15.0	13.1	13.1	13.1
Electrical power input in thermostat-OFF mode (Pto)	W	0.0	0.0	0.0	0.0
Electrical power input in OFF mode (Poff)	W	15.0	13.1	13.1	13.1
Electrical power input in crankcase heater mode (Pck)	W	0.0	0.0	0.0	0.0
Sound power level of outdoor unit (L _{WA})	dB(A)	64	64	65	67
Capacity control mode	-	Variable (Inverter)			
Integrated supplementary heater	kW	No			
Nominal outdoor air flow	m ³ /h	2682	4800	5400	6000

RASM-(4-6)NE

Model		RASM-4NE	RASM-5NE	RASM-6NE
Electrical power input in stand-by mode (Psb)	W	19.1	19.1	19.1
Electrical power input in thermostat-OFF mode (Pto)	W	0.0	0.0	0.0
Electrical power input in OFF mode (Poff)	W	19.1	19.1	19.1
Electrical power input in crankcase heater mode (Pck)	W	0.0	0.0	0.0
Sound power level of outdoor unit (L _{WA})	dB(A)	64	65	67
Capacity control mode	-	Variable (Inverter)		
Integrated supplementary heater	kW	No		
Nominal outdoor air flow	m ³ /h	4800	5400	6000

3.2.3 General ERP data for combi heaters (YUTAKI S COMBI & S80)

3.2.3.1 YUTAKI S COMBI

RAS-(2-3)WH(V)NP + RWD-(2.0-3.0)NWE-(200/260)S(-K)

Model	Outdoor unit	RAS-2WHVNP		RAS-2.5WHVNP		RAS-3WHVNP	
	Indoor unit	RWD-2.0 NWE- 200S(-K)	RWD-2.0 NW(S)E- 260S(-K)	RWD-2.5 NWE- 200S(-K)	RWD-2.5 NW(S)E- 260S(-K)	RWD-3.0 NWE- 200S(-K)	RWD-3.0 NW(S)E- 260S(-K)
Declared profile	-	L	XL	L	XL	L	XL
Ability to work during OFF peak hours	-	Yes					
AVERAGE climate							
Water heating energy efficiency (η_{wh})	%	132	136	132	136	132	136
Water heating energy class	-	A+	A+	A+	A+	A+	A+
Daily electricity consumption	kW·h	3.53	5.61	3.53	5.61	3.53	5.61
Annual energy consumption	kW·h	777	1234	777	1234	777	1234
WARMER climate							
Water heating energy efficiency (η_{wh})	%	145	150	145	150	145	150
Daily energy consumption	kW·h	3.21	3.12	3.21	706	3.21	706
Annual energy consumption	kW·h	706	686	3.12	686	3.12	686
COLDER climate							
Water heating energy efficiency (η_{wh})	%	112	116	112	116	112	116
Daily energy consumption	kW·h	4.16	4.03	4.16	4.03	4.16	4.03
Annual energy consumption	kW·h	914	887	914	887	914	887

RAS-(4-6)WH(V)NPE + RWD-(4-6)(C)NWE-(200/260)S

Model	Outdoor unit	RAS-4WH(V)NPE		RAS-5WH(V)NPE		RAS-6WH(V)NPE	
	Indoor unit	RWD-4.0 NWE- 200S(-K)	RWD-4.0 NW(S)E- 260S(-K)	RWD-5.0 NWE- 200S(-K)	RWD-5.0 NW(S)E- 260S(-K)	RWD-6.0 NWE- 200S(-K)	RWD-6.0 NW(S)E- 260S(-K)
Declared profile	-	L	XL	L	XL	L	XL
Ability to work during OFF peak hours	-	Yes					
AVERAGE climate							
Water heating energy efficiency (η_{wh})	%	130	134	130	134	130	134
Water heating energy class	-	A+	A+	A+	A+	A+	A+
Daily electricity consumption	kW·h	3.59	5.69	3.59	5.69	3.59	5.69
Annual energy consumption	kW·h	789	1252	789	1252	789	1252
WARMER climate							
Water heating energy efficiency (η_{wh})	%	143	147	143	147	143	147
Daily energy consumption	kW·h	3.26	3.16	3.26	3.16	3.26	3.16
Annual energy consumption	kW·h	717	696	717	696	717	696
COLDER climate							
Water heating energy efficiency (η_{wh})	%	111	114	111	114	111	114
Daily energy consumption	kW·h	4.22	4.09	4.22	4.09	4.22	4.09
Annual energy consumption	kW·h	928	900	928	900	928	900

3.2.3.2 YUTAKI S80

RAS-(4-6)WH(V)NPE + RWH-(4.0-6.0)(V)NFWE + DHWS(200/260)S-2.7H2E

Model	Outdoor unit	RAS-4WH(V)NPE		RAS-5WH(V)NPE		RAS-6WH(V)NPE	
	Indoor unit	RWH-4.0VNFWE		RWH-5.0VNFWE		RWH-6.0VNFWE	
	DHW tank	DHWS200S-2.7H2E	DHWS260S-2.7H2E	DHWS200S-2.7H2E	DHWS260S-2.7H2E	DHWS200S-2.7H2E	DHWS260S-2.7H2E
Declared profile	-	L	XL	L	XL	L	XL
Ability to work during OFF peak hours	-	Yes					
AVERAGE climate							
Water heating energy efficiency (η_{wh})	%	129	133	129	133	129	133
Water heating energy class	-	A+	A+	A+	A+	A+	A+
Daily electricity consumption	kW·h	3.61	5.74	3.61	5.74	3.61	5.74
Annual energy consumption	kW·h	795	1262	795	1262	795	1262
WARMER climate							
Water heating energy efficiency (η_{wh})	%	142	146	142	146	142	146
Daily energy consumption	kW·h	3.29	3.19	3.29	3.19	3.29	3.19
Annual energy consumption	kW·h	723	7.01	723	7.01	723	7.01
COLDER climate							
Water heating energy efficiency (η_{wh})	%	110	113	110	113	110	113
Daily energy consumption	kW·h	4.25	4.12	4.25	4.12	4.25	4.12
Annual energy consumption	kW·h	935	907	935	907	935	907

**NOTE**

RWH-(V)NFE units are conceived for only heating operation, but a DHW tank could also be installed beside the indoor unit thus providing DHW operation. In this case, the whole system is considered as a "Heat pump combination heater".

3.2.4 General ERP data for hot water storage tanks (YUTAKI S , YUTAKI M & YUTAKI S 80 RWH-4.0VNFWE

Model		DHWT-200S-3.0H2E	DHWT-300S-3.0H2E
Storage volume	L	194	284
Standing loss	W	47.3	62.8
Energy efficiency class	-	B	B

3.3 General specifications

3.3.1 Considerations

- The sound data is based on the following conditions:
 - Outdoor ambient temperature (DB/WB): 7/6°C.
 - Water inlet/outlet temperature: 47/55°C (mark: *1); 30/35°C (mark: *2).
 - Distance of the unit from the measuring point: At 1 meter from the unit's front surface; 1,5 meter from floor level.
 - The sound pressure level is measured in an anechoic chamber, so reflected sound should be taken into consideration when installing the unit.
 - The sound power level is measured in a reverberant room, in accordance with the standard EN12102. Used environment conditions are the same that specified in EN14511 for performance test.
- The nominal water flow rate is calculated under the following conditions:
 - Outdoor ambient temperature (DB/WB): 7/6°C.
 - Water inlet/outlet temperature: 47/55°C (mark: *1); 30/35°C (mark: *2).
- *Regarding data marked with mark: *3, it corresponds to the height of the unit with the minimum mounting foot height. This value can be adjusted up to +30 mm.*
- *For specific details about data corresponding to the working range, please refer to the chapter "6. Working range".*

Keywords:

- *DB: Dry bulb*
- *WB: Wet bulb*
-

3.3.2 Split system - Outdoor unit

Model		RAS-2WHVNP	RAS-2.5WHVNP	RAS-3WHVNP
Power supply	-	1~ 230V 50Hz		
Noise level (sound pressure)	dB(A)	46	47	50
Noise level (sound power)	(*1)	61	63	64
	(*2)	59	60	61
Air flow	m ³ /min	40.6	40.6	44.7
Cabinet colour	-	Natural grey (1.0Y 8.5/0.5)		
Dimensions (H x W x D)	mm	600 x 792 x 300		
Net weight	kg	43	43	44
Gross weight	kg	48	48	49
Piping diameter (liquid / gas)	mm (inch)	Ø6.35 (1/4) / Ø12.7 (1/2)	Ø6.35 (1/4) / Ø12.7 (1/2)	Ø9.52 (3/8) / Ø15.88 (5/8)
Minimum piping length	m	5		
Maximum chargeless piping length	m	15		
Maximum piping length (additional refrigerant charge needed)	m (g/m)	50 (30)		50 (40)
Height difference between OU and IU (higher OU / lower OU)	m	30 / 20		
Working range (cooling // heating // DHW)	°C (DB)	10~46 // -15~25 / -15~35		
Refrigerant	-	R410A		
Refrigerant charge before shipment	kg	1.4	1.5	1.7
Compressor type	-	Scroll DC Inverter driven		

Model		RAS-4WHVNPE	RAS-5WHVNPE	RAS-6WHVNPE
Power supply	-	1~ 230V 50Hz		
Noise level (sound pressure)	dB(A)	49	50	50
Noise level (sound power)	(*1)	64	65	67
	(*2)	63	64	65
Air flow	m ³ /min	80	90	100
Cabinet colour	-	Natural grey (1.0Y 8.5/0.5)		
Dimensions (H x W x D)	mm	1380 x 950 x 370		
Net weight	kg	103	103	103
Gross weight	kg	116	116	116
Piping diameter (liquid / gas)	mm (inch)	Ø9.52 (3/8) / Ø15.88 (5/8)	Ø9.52 (3/8) / Ø15.88 (5/8)	Ø9.52 (3/8) / Ø15.88 (5/8)
Minimum piping length	m	5		
Maximum chargeless piping length	m	15		
Maximum piping length (additional refrigerant charge needed)	m (g/m)	75 (60)		
Height difference between OU and IU (higher OU / lower OU)	m	30 / 20		
Working range (cooling // heating // DHW)	°C (DB)	10~46 // -25~25 / -25~35		
Refrigerant	-	R410A		
Refrigerant charge before shipment	kg	3.3	3.4	3.4
Compressor type	-	Scroll DC Inverter driven		

Model		RAS-4WHNPE	RAS-5WHNPE	RAS-6WHNPE
Power supply	-	3N~ 400V 50Hz		
Noise level (sound pressure)	dB(A)	49	50	50
Noise level (sound power)	(*1)	64	65	67
	(*2)	63	64	65
Air flow	m ³ /min	80	90	100
Cabinet colour	-	Natural grey (1.0Y 8.5/0.5)		
Dimensions (H x W x D)	mm	1380 x 950 x 370		
Net weight	kg	103	103	103
Gross weight	kg	116	116	116
Piping diameter (liquid / gas)	mm (inch)	Ø9.52 (3/8) / Ø15.88 (5/8)	Ø9.52 (3/8) / Ø15.88 (5/8)	Ø9.52 (3/8) / Ø15.88 (5/8)
Minimum piping length	m	5		
Maximum chargeless piping length	m	15		
Maximum piping length (additional refrigerant charge needed)	m (g/m)	75 (60)		
Height difference between OU and IU (higher OU / lower OU)	m	30 / 20		
Working range (cooling // heating // DHW)	°C (DB)	10~+46 // -25~+25 / -25~+35		
Refrigerant	-	R410A		
Refrigerant charge before shipment	kg	3.3	3.4	3.4
Compressor type	-	Scroll DC Inverter driven		

Model		RAS-8WHNPE	RAS-10WHNPE
Power supply	-	3N~ 400V 50Hz	
Noise level (sound pressure)	dB(A)	59	60
Noise level (sound power)	(*1)	73	74
	(*2)	71	72
Air flow	m ³ /min	127	134
Cabinet colour	-	Natural grey (1.0Y 8.5/0.5)	
Dimensions (H x W x D)	mm	1380 x 950 x 370	
Net weight	kg	137	139
Gross weight	kg	152	154
Piping diameter (liquid / gas)	mm (inch)	Ø9.52 (3/8) / Ø25.4	Ø12.70 (1/2) / Ø25.4
Minimum piping length	m	5	
Maximum chargeless piping length	m	15	
Maximum piping length (additional refrigerant charge needed)	m (g/m)	70 (*)	
Height difference between OU and IU (higher OU / lower OU)	m	30 / 20	
Working range (cooling // heating // DHW)	°C (DB)	10~+46 // -25~+25 / -25~+35	
Refrigerant	-	R410A	
Refrigerant charge before shipment	kg	5.0	5.3
Compressor type	-	Scroll DC Inverter driven	

(*) Need to be calculated.

3.3.3 Split system - Indoor unit

3.3.3.1 YUTAKI S

Model			RWM-2.0NE	RWM-2.5NE	RWM-3.0NE
Power supply		-	1~ 230V 50Hz		
Noise level (sound power)		dB(A)	37	37	37
Nominal water flow	WIT: 30 °C / WOT: 35 °C	m³/h	0.77	1.03	1.29
	ΔT: 5 °C				
Cabinet	Material	-	Precoated galvanised steel		
	Colour	-	Pure white (RAL 9010)		
Unit dimensions	Height (with connections)	mm	712 (782)		
	Width	mm	450		
	Depth	mm	275		
Packaging dimensions	Height	mm	468		
	Width	mm	905		
	Depth	mm	539		
Packaging volume		m³	0.23		
Packaging materials		-	Wood - Carton - Plastic		
Net weight		kg	37	38	39
Gross weight		kg	44	45	46
Refrigerant pipes connection	Connection type	-	Flare nut connection		
	Liquid pipe diameter	mm (in.)	Ø6.35 (1/4")	Ø9.52 (3/8")	
	Gas pipe diameter	mm (in.)	Ø15.88 (5/8")		
Space heating pipes connection	Connection type	-	Screwed connection		
	Shut-off valves	mm (in.)	G 1" (male) - G 1" (male)		
	Inlet pipe diameter	mm (in.)	G 1" (female)		
	Outlet pipe diameter	mm (in.)	G 1" (female)		
Working range (Heating)	Outdoor ambient temperature	°C (DB)	-15~25		
	Outlet water temperature	°C	20~55		
Working range (Cooling)	Outdoor ambient temperature	°C (DB)	10~46		
	Outlet water temperature	°C	5~22		
Working range (DHW)	Outdoor ambient temperature	°C (DB)	-15~35		
	Tank water temperature	°C	30~75		

Model			RWM-4.0NE	RWM-5.0NE	RWM-6.0NE
Power supply		-	1~ 230V 50Hz / 3N~ 400V 50Hz		
Noise level (sound power)		dB(A)	39	39	39
Nominal water flow	WIT: 30 °C / WOT: 35 °C ΔT: 5 °C	m ³ /h	1.89	2.41	2.75
Cabinet	Material	-	Precoated galvanised steel		
	Colour	-	Pure white (RAL 9010)		
Unit dimensions	Height (with connections)	mm	890 (960)		
	Width	mm	520		
	Depth	mm	360		
Packaging dimensions	Height	mm	546		
	Width	mm	1120		
	Depth	mm	610		
Packaging volume		m ³	0.37		
Packaging materials		-	Wood - Carton - Plastic		
Net weight		kg	46	48	
Gross weight		kg	61	63	
Refrigerant pipes connection	Connection type	-	Flare nut connection		
	Liquid pipe diameter	mm (in.)	Ø9.52 (3/8")		
	Gas pipe diameter	mm (in.)	Ø15.88 (5/8")		
Space heating pipes connection	Connection type	-	Screwed connection		
	Shut-off valves	mm (in.)	G 1-1/4" (male) - G 1-1/4" (male)		
	Inlet pipe diameter	mm (in.)	G 1-1/4" (female)		
	Outlet pipe diameter	mm (in.)	G 1-1/4" (female)		
Working range (Heating)	Outdoor ambient temperature	°C (DB)	-25~25		
	Outlet water temperature	°C	20~60		
Working range (Cooling)	Outdoor ambient temperature	°C (DB)	10~46		
	Outlet water temperature	°C	5~22		
Working range (DHW)	Outdoor ambient temperature	°C (DB)	-25~35		
	Tank water temperature	°C	30~75		

Model			RWM-8.0NE	RWM-10.0NE
Power supply		-	3N~ 400V 50Hz	
Noise level (sound power)		dB(A)	47	47
Nominal water flow	WIT: 30 °C / WOT: 35 °C ΔT: 5 °C	m ³ /h	3.44	4.13
Cabinet	Material	-	Precoated galvanised steel	
	Colour	-	Pure white (RAL 9010)	
Unit dimensions	Height (with connections)	mm	890 (960)	
	Width	mm	670	
	Depth	mm	360	
Packaging dimensions	Height	mm	546	
	Width	mm	1120	
	Depth	mm	760	
Packaging volume		m ³	0.46	
Packaging materials		-	Wood - Carton - Plastic	
Net weight		kg	60	62
Gross weight		kg	76	78
Refrigerant pipes connection	Connection type	-	Liquid pipe: Flare nut connection; Gas pipe: Brazed connection	
	Liquid pipe diameter	mm (in.)	Ø9.52 (3/8")	Ø12.7 (3/8")
	Gas pipe diameter	mm (in.)	Ø25.4 (1")	
Space heating pipes connection	Connection type	-	Screwed connection	
	Shut-off valves	mm (in.)	G 1-1/4" (male) - G 1-1/4" (male)	
	Inlet pipe diameter	mm (in.)	G 1-1/4" (female)	
	Outlet pipe diameter	mm (in.)	G 1-1/4" (female)	
Working range (Heating)	Outdoor ambient temperature	°C (DB)	-25~25	
	Outlet water temperature	°C	20~60	
Working range (Cooling)	Outdoor ambient temperature	°C (DB)	10~46	
	Outlet water temperature	°C	5~22	
Working range (DHW)	Outdoor ambient temperature	°C (DB)	-25~35	
	Tank water temperature	°C	30~75	

3.3.3.2 YUTAKI S COMBI

◆ Standard model

Model		RWD-2.0NWE- (200/260)S	RWD-2.5NWE- (200/260)S	RWD-3.0NWE- (200/260)S
Power supply		-	1~ 230V 50Hz	
Noise level (sound power)		dB(A)	37	37
Nominal water flow	WIT: 30 °C / WOT: 35 °C ΔT: 5 °C	m ³ /h	0.77	1.03
Cabinet	Material	-	Precoated galvanised steel	
	Colour	-	Pure white (RAL 9010)	
Unit dimensions	Height (with connections)	mm	1750 (1816) (*3)	
	Width	mm	600	
	Depth	mm	733	
Packaging dimensions	Height	mm	1950	
	Width	mm	651	
	Depth	mm	770	
Packaging volume		m ³	0.98	
Packaging materials		-	Wood - Carton - Plastic	
Net weight	Tank model: 200 L	kg	120	121
	Tank model: 260 L		135	136
Gross weight	Tank model: 200 L	kg	131	132
	Tank model: 260 L		146	147
Refrigerant pipes connection	Connection type	-	Flare nut connection	
	Liquid pipe diameter	mm (in.)	Ø6.35 (1/4")	Ø9.52 (3/8")
	Gas pipe diameter	mm (in.)	Ø15.88 (5/8")	
Space heating pipes connection	Connection type	-	Screwed connection	
	Shut-off valves	mm (in.)	G 1" (male) - G 1" (male)	
	Inlet pipe diameter	mm (in.)	G 1" (female)	
	Outlet pipe diameter	mm (in.)	G 1" (female)	
DHW pipes connection	Connection type	-	Screwed connection	
	Inlet pipe diameter	mm (in.)	G 3/4" (female)	
	Outlet pipe diameter	mm (in.)	G 3/4" (female)	
Working range (Heating)	Outdoor ambient temperature	°C (DB)	-15~25	
	Outlet water temperature	°C	20~55	
Working range (Cooling)	Outdoor ambient temperature	°C (DB)	10~46	
	Outlet water temperature	°C	5~22	
Working range (DHW)	Outdoor ambient temperature	°C (DB)	-15~35	
	Tank water temperature	°C	30~75	

General specifications

Model		RWD-4.0NWE- (200/260)S	RWD-5.0NWE- (200/260)S	RWD-6.0NWE- (200/260)S
Power supply		-	1~ 230V 50Hz / 3N~ 400V 50Hz	
Noise level (sound power)		dB(A)	39	39
Nominal water flow	WIT: 30 °C / WOT: 35 °C ΔT: 5 °C	m ³ /h	1.89	2.41
Cabinet	Material	-	Precoated galvanised steel	
	Colour	-	Pure white (RAL 9010)	
Unit dimensions	Height (with connections)	mm	1750 (1816) (*3)	
	Width	mm	600	
	Depth	mm	733	
Packaging dimensions	Height	mm	1950	
	Width	mm	651	
	Depth	mm	770	
Packaging volume		m ³	0.98	
Packaging materials		-	Wood - Carton - Plastic	
Net weight	Tank model: 200 L	kg	124	126
	Tank model: 260 L		139	141
Gross weight	Tank model: 200 L	kg	135	137
	Tank model: 260 L		150	152
Refrigerant pipes connection	Connection type	-	Flare nut connection	
	Liquid pipe diameter	mm (in.)	Ø9.52 (3/8")	
	Gas pipe diameter	mm (in.)	Ø15.88 (5/8")	
Space heating pipes connection	Connection type	-	Screwed connection	
	Shut-off valves	mm (in.)	G 1-1/4" (male) - G 1-1/4" (male)	
	Inlet pipe diameter	mm (in.)	G 1-1/4" (female)	
	Outlet pipe diameter	mm (in.)	G 1-1/4" (female)	
DHW pipes connection	Connection type	-	Screwed connection	
	Inlet pipe diameter	mm (in.)	G 3/4" (female)	
	Outlet pipe diameter	mm (in.)	G 3/4" (female)	
Working range (Heating)	Outdoor ambient temperature	°C (DB)	-25~25	
	Outlet water temperature	°C	20~60	
Working range (Cooling)	Outdoor ambient temperature	°C (DB)	10~46	
	Outlet water temperature	°C	5~22	
Working range (DHW)	Outdoor ambient temperature	°C (DB)	-25~35	
	Tank water temperature	°C	30~75	

◆ Model for solar combination

Model		RWD-2.0NWSE-260S	RWD-2.5NWSE-260S	RWD-3.0NWSE-260S
Power supply	-	1~ 230V 50Hz		
Noise level (sound power)	dB(A)	37	37	37
Nominal water flow	WIT: 30 °C / WOT: 35 °C ΔT: 5 °C	m ³ /h	0.77	1.03
Cabinet	Material	-	Precoated galvanised steel	
	Colour	-	Pure white (RAL 9010)	
Unit dimensions	Height (with connections)	mm	1750 (1816) (*3)	
	Width	mm	600	
	Depth	mm	733	
Packaging dimensions	Height	mm	1950	
	Width	mm	651	
	Depth	mm	770	
Packaging volume	m ³	0.98		
Packaging materials	-	Wood - Carton - Plastic		
Net weight	kg	138		139
Gross weight	kg	149		150
Refrigerant pipes connection	Connection type	-	Flare nut connection	
	Liquid pipe diameter	mm (in.)	Ø6.35 (1/4")	Ø9.52 (3/8")
	Gas pipe diameter	mm (in.)	Ø15.88 (5/8")	
Space heating pipes connection	Connection type	-	Screwed connection	
	Shutdown valves	mm (in.)	G 1" (male) - G 1" (male)	
	Inlet pipe diameter	mm (in.)	G 1" (female)	
	Outlet pipe diameter	mm (in.)	G 1" (female)	
DHW pipes connection	Connection type	-	Screwed connection	
	Inlet pipe diameter	mm (in.)	G 3/4" (female)	
	Outlet pipe diameter	mm (in.)	G 3/4" (female)	
Solar pipes connection	Connection type	-	Screwed connection	
	Inlet pipe diameter	mm (in.)	G 1/2" (male)	
	Outlet pipe diameter	mm (in.)	G 1/2" (male)	
Working range (Heating)	Outdoor ambient temperature	°C (DB)	-15~25	
	Outlet water temperature	°C	20~55	
Working range (Cooling)	Outdoor ambient temperature	°C (DB)	10~46	
	Outlet water temperature	°C	5~22	
Working range (DHW)	Outdoor ambient temperature	°C (DB)	-15~35	
	Tank water temperature	°C	30~75	

General specifications

Model		RWD-4.0NWSE-260S	RWD-5.0NWSE-260S	RWD-6.0NWSE-260S
Power supply	-	1~ 230V 50Hz / 3N~ 400V 50Hz		
Noise level (sound power)	dB(A)	39	39	39
Nominal water flow	WIT: 30 °C / WOT: 35 °C ΔT: 5 °C	m ³ /h	1.89	2.41
Cabinet	Material	-	Precoated galvanised steel	
	Colour	-	Pure white (RAL 9010)	
Unit dimensions	Height (with connections)	mm	1750 (1816) (*3)	
	Width	mm	600	
	Depth	mm	733	
Packaging dimensions	Height	mm	1950	
	Width	mm	651	
	Depth	mm	770	
Packaging volume	m ³	0.98		
Packaging materials	-	Wood - Carton - Plastic		
Net weight	kg	142	144	
Gross weight	kg	153	155	
Refrigerant pipes connection	Connection type	-	Flare nut connection	
	Liquid pipe diameter	mm (in.)	Ø9.52 (3/8")	
	Gas pipe diameter	mm (in.)	Ø15.88 (5/8")	
Space heating pipes connection	Connection type	-	Screwed connection	
	Shut-off valves	mm (in.)	G 1-1/4" (male) - G 1-1/4" (male)	
	Inlet pipe diameter	mm (in.)	G 1-1/4" (female)	
	Outlet pipe diameter	mm (in.)	G 1-1/4" (female)	
DHW pipes connection	Connection type	-	Screwed connection	
	Inlet pipe diameter	mm (in.)	G 3/4" (female)	
	Outlet pipe diameter	mm (in.)	G 3/4" (female)	
Solar pipes connection	Connection type	-	Screwed connection	
	Inlet pipe diameter	mm (in.)	G 1/2" (male)	
	Outlet pipe diameter	mm (in.)	G 1/2" (male)	
Working range (Heating)	Outdoor ambient temperature	°C (DB)	-25~25	
	Outlet water temperature	°C	20~60	
Working range (Cooling)	Outdoor ambient temperature	°C (DB)	10~46	
	Outlet water temperature	°C	5~22	
Working range (DHW)	Outdoor ambient temperature	°C (DB)	-25~35	
	Tank water temperature	°C	30~75	

◆ Model for UK market

Model		RWD-2.0NWE- (200/260)S-K	RWD-2.5NWE- (200/260)S-K	RWD-3.0NWE- (200/260)S-K
Power supply	-	1~ 230V 50Hz		
Noise level (sound power)	dB(A)	37	37	37
Nominal water flow	WIT: 30 °C / WOT: 35 °C ΔT: 5 °C	m ³ /h	0.77	1.03
Cabinet	Material	-	Precoated galvanised steel	
	Colour	-	Pure white (RAL 9010)	
Unit dimensions	Height (with connections)	mm	1750 (1816) (*3)	
	Width	mm	600	
	Depth	mm	733	
Packaging dimensions	Height	mm	1950	
	Width	mm	651	
	Depth	mm	770	
Packaging volume	m ³	0.98		
Packaging materials	-	Wood - Carton - Plastic		
Net weight	Tank model: 200 L	kg	121	122
	Tank model: 260 L		136	137
Gross weight	Tank model: 200 L	kg	132	133
	Tank model: 260 L		147	148
Refrigerant pipes connection	Connection type	-	Flare nut connection	
	Liquid pipe diameter	mm (in.)	Ø6.35 (1/4")	Ø9.52 (3/8")
	Gas pipe diameter	mm (in.)	Ø15.88 (5/8")	
Space heating pipes connection	Connection type	-	Screwed connection	
	Shut-off valves	mm (in.)	G 1" (male) - G 1" (male)	
	Inlet pipe diameter	mm (in.)	G 1" (female)	
	Outlet pipe diameter	mm (in.)	G 1" (female)	
DHW pipes connection	Connection type	-	Screwed connection	
	Inlet pipe diameter	mm (in.)	G 3/4" (female)	
	Outlet pipe diameter	mm (in.)	G 3/4" (female)	
Working range (Heating)	Outdoor ambient temperature	°C (DW)	-15~25	
	Outlet water temperature	°C	20~55	
Working range (Cooling)	Outdoor ambient temperature	°C (DB)	10~46	
	Outlet water temperature	°C	5~22	
Working range (DHW)	Outdoor ambient temperature	°C (DB)	-15~35	
	Tank water temperature	°C	30~75	

General specifications

Model		RWD-4.0NWE- (200/260)S-K	RWD-5.0NWE- (200/260)S-K	RWD-6.0NWE- (200/260)S-K
Power supply		-	1~ 230V 50Hz / 3N~ 400V 50Hz	
Noise level (sound power)		dB(A)	39	39
Nominal water flow	WIT: 30 °C / WOT: 35 °C ΔT: 5 °C	m³/h	1.89	2.41
Cabinet	Material	-	Precoated galvanised steel	
	Colour	-	Pure white (RAL 9010)	
Unit dimensions	Height (with connections)	mm	1750 (1816) (*3)	
	Width	mm	600	
	Depth	mm	733	
Packaging dimensions	Height	mm	1950	
	Width	mm	651	
	Depth	mm	770	
Packaging volume		m³	0.98	
Packaging materials		-	Wood - Carton - Plastic	
Net weight	Tank model: 200 L	kg	125	127
	Tank model: 260 L		140	142
Gross weight	Tank model: 200 L	kg	136	138
	Tank model: 260 L		151	153
Refrigerant pipes connection	Connection type	-	Flare nut connection	
	Liquid pipe diameter	mm (in.)	Ø9.52 (3/8")	
	Gas pipe diameter	mm (in.)	Ø15.88 (5/8")	
Space heating pipes connection	Connection type	-	Screwed connection	
	Shut-off valves	mm (in.)	G 1-1/4" (male) - G 1-1/4" (male)	
	Inlet pipe diameter	mm (in.)	G 1-1/4" (female)	
	Outlet pipe diameter	mm (in.)	G 1-1/4" (female)	
DHW pipes connection	Connection type	-	Screwed connection	
	Inlet pipe diameter	mm (in.)	G 3/4" (female)	
	Outlet pipe diameter	mm (in.)	G 3/4" (female)	
Working range (Heating)	Outdoor ambient temperature	°C (DB)	-25~25	
	Outlet water temperature	°C	20~60	
Working range (Cooling)	Outdoor ambient temperature	°C (DB)	10~46	
	Outlet water temperature	°C	5~22	
Working range (DHW)	Outdoor ambient temperature	°C (DB)	-25~35	
	Tank water temperature	°C	30~75	

3.3.3.3 YUTAKI S80

◆ Indoor unit

Version for indoor unit alone

Model		RWH-4.0(V)NFE	RWH-5.0(V)NFE	RWH-6.0(V)NFE	
Power supply		-	RWH-(4.0-6.0)VNFE: 1~ 230V 50Hz RWH-(4.0-6.0)NFE: 3N~ 400V 50Hz		
Nominal water flow	WIT: 47 °C / WOT: 55 °C ΔT: 5 °C	m ³ /h	1.26	1.64	1.83
	WIT: 55 °C / WOT: 65 °C ΔT: 10 °C	m ³ /h	1.00	1.20	1.38
Noise level (sound power)		dB(A)	57	57	58
Cabinet	Material	-	Precoated galvanised steel		
	Colour	-	Pure white (RAL 9010)		
Unit dimensions	Height (with connections) (*)	mm	751 (802) (*3)		
	Width	mm	600		
	Depth	mm	623		
Packaging dimensions	Height	mm	982		
	Width	mm	675		
	Depth	mm	671		
Packaging volume		m ³	0.44		
Packaging materials		-	Wood - Carton - Plastic - Polypropylene bands		
Net weight (1~ / 3N~)		kg	126 / 127	129 / 130	
Gross weight (1~ / 3N~)		kg	137 / 138	140 / 141	
Refrigerant pipes connection	Connection type	-	Flare nut connection		
	Liquid pipe diameter	mm (in.)	Ø9.52 (3/8")		
	Gas pipe diameter	mm (in.)	Ø15.88 (5/8")		
Space heating pipes connection	Connection type	-	Screwed connection		
	Shut-off valves	mm (in.)	G 1-1/4" (male) - G 1-1/4" (male)		
	Inlet pipe diameter	mm (in.)	G 1-1/4" (female)		
	Outlet pipe diameter	mm (in.)	G 1-1/4" (female)		
Working range (Heating)	Outdoor ambient temperature	°C (DB)	-25~25		
	Outlet water temperature	°C	20~80		
Working range (DHW)	Outdoor ambient temperature	°C (DB)	-25~35		
	Tank water temperature	°C	30~75		
Refrigerant		-	R-134a		
Refrigerant charge		kg	1.9		
Compressor type		-	Scroll DC Inverter driven		

Version for combination with DHW tank

Model			RWH-4.0(V)NFW	RWH-5.0(V)NFW	RWH-6.0(V)NFW
Power supply		-	RWH-(4.0-6.0)NFW: 1~ 230V 50Hz RWH-(4.0-6.0)NFW: 3N~ 400V 50Hz		
Nominal water flow	WIT: 47 °C / WOT: 55 °C ΔT: 5 °C	m ³ /h	1.26	1.64	1.83
	WIT: 55 °C / WOT: 65 °C ΔT: 10 °C	m ³ /h	1.00	1.20	1.38
Noise level (sound power)		dB(A)	57	57	58
Cabinet	Material	-	Precoated galvanised steel		
	Colour	-	Pure white (RAL 9010)		
Unit dimensions	Height	mm	751 (*3)		
	Width	mm	600		
	Depth (with connections)	mm	623 (680)		
Packaging dimensions	Height	mm	926		
	Width	mm	728		
	Depth	mm	671		
Packaging volume		m ³	0.45		
Packaging materials		-	Wood - Carton - Plastic - Polypropylene bands		
Net weight (1~ / 3N~)		kg	136 / 137	139 / 140	
Gross weight (1~ / 3N~)		kg	147 / 148	150 / 151	
Refrigerant pipes connection	Connection type	-	Flare nut connection		
	Liquid pipe diameter	mm (in.)	Ø9.52 (3/8")		
	Gas pipe diameter	mm (in.)	Ø15.88 (5/8")		
Space heating pipes connection	Connection type	-	Screwed connection		
	Shut-off valves	mm (in.)	G 1-1/4" (male) - G 1-1/4" (male)		
	Inlet pipe diameter	mm (in.)	G 1-1/4" (female)		
	Outlet pipe diameter	mm (in.)	G 1-1/4" (female)		
Heating coil pipes connection (*)	Connection type	-	Flexible pipe connection		
	Heating coil inlet diameter (3-way valve)	mm (in.)	Flexible pipe (G 1" male)		
	Heating outlet inlet diameter (T-branch)	mm (in.)	Flexible pipe (G 1" male)		
Working range (Heating)	Outdoor ambient temperature	°C (DB)	-25~25		
	Outlet water temperature	°C	20~80		
Working range (DHW)	Outdoor ambient temperature	°C (DB)	-25~35		
	Tank water temperature	°C	30~75		
Refrigerant		-	R-134a		
Refrigerant charge		kg	1.9		
Compressor type		-	Scroll DC Inverter driven		

(*): These models are ready for combination with YUTAKI S80 DHW tank accessory. In this case, the two flexible water pipes factory-supplied with the DHW tank must be connected to the 3-way valve and T-branch connections of the indoor unit.

◆ Domestic hot water tank

Model			DHWS200S-2.7H2E	DHWS260S-2.7H2E	
Power supply		-	1~ 230V 50Hz		
Cabinet	Material	-	Precoated galvanised steel		
	Colour	-	Pure white (RAL 9010)		
Unit dimensions	Height	Separated tank	mm	1282 (*3)	1591 (*3)
		Integrated tank	mm	1980 (*3)	2289 (*3)
	Width		mm	600	
	Depth (with connections)		mm	648 (675)	
Packaging dimensions	Height		mm	1444	1753
	Width		mm	644	
	Depth		mm	722	
Packaging volume		m ³	0.67	0.82	
Packaging material		-	Wood - Carton - Plastic - Polypropylene bands		
Net weight		kg	62	77	
Gross weight		kg	72	88	
Tank	Net water volume		L	190	250
	Material		-	AISI 444	
	Maximum tank working temperature		°C	75	
	Maximum tank water working pressure		bar	10	
	Maximum heating coil water working temperature		°C	75	
	Maximum heating coil water working pressure		bar	3	
Tank insulation	Material		-	NEOPOR	
	Thickness		mm	50	
Heat exchanger	Quantity		-	1	
	Coil surface area		m ²	1.6	
Tank's heater	Quantity		-	1	
	Heater rating		kW	2.7	
	Type		-	Immersion heater type	
Piping connections	Heating coil inlet connection		in.	Flexible pipe (G 1" male)	
	Heating coil outlet connection		in.	Flexible pipe (G 1" male)	
	DHW inlet connection		in.	Flexible pipe (G 3/4" male)	
	DHW outlet connection		in.	Flexible pipe (G 3/4" male)	
Mechanical thermostat (adjustable and security)		-	Yes (adjustable 28~80°C ; cut-out: 90°C)		
Protection		-	Anode protection		
Wired remote controller		-	PC-ARFHE		

3.3.4 Monobloc system - YUTAKI M

Model		RASM-3VNE	RASM-4VNE	RASM-5VNE	RASM-6VNE	
Power supply		1~ 230V 50Hz				
Noise level (sound pressure) (*1)(*2)		dB(A)				
Noise level (sound power)		(*1)	64	64	65	67
		(*2)	61	63	64	65
Nominal water flow	WIT: 30 °C / WOT: 35 °C ΔT: 5 °C	m ³ /h	1.29	1.89	2.41	2.75
Cabinet	Material	Precoated galvanised steel				
	Colour	Natural grey (1.0Y 8.5/0.5)				
Unit dimensions	Height	mm	800	1380		
	Width	mm	1252	1252		
	Depth	mm	370	370		
Packaging dimensions	Height	mm	935	1515		
	Width	mm	1312			
	Depth	mm	460			
Packaging volume		m ³	0.56	0.91		
Packaging materials		Paper + Wood + Plastic				
Net weight		kg	105	125	130	134
Gross weight		kg	115	135	140	144
Space heating pipes connection	Connection type	Screwed connection				
	Shut-off valves	mm (in.)	G 1" (male) - G 1" (male)	G 1-1/4" (male) - G 1-1/4" (male)		
	Inlet pipe diameter	mm (in.)	G 1" (female)	G 1-1/4" (female)		
	Outlet pipe diameter	mm (in.)	G 1" (female)	G 1-1/4" (female)		
Working range (Heating)	Outdoor ambient temperature	°C (DB)	-25~25			
	Outlet water temperature	°C	20~55	20~60		
Working range (Cooling)	Outdoor ambient temperature	°C (DB)	10~46			
	Outlet water temperature	°C	5~22			
Working range (DHW)	Outdoor ambient temperature	°C (DB)	-25~35			
	Tank water temperature	°C	30~75			
Refrigerant		R410A				
Refrigerant charge		kg	2.4	2.8	3.1	3.1
Compressor type		Scroll DC Inverter driven				

Blank data: To be informed later.

Model			RASM-4NE	RASM-5NE	RASM-6NE
Power supply		-	3N~ 400V 50Hz		
Noise level (sound pressure) (*1)(*2)		dB(A)			
Noise level (sound power)	(*1)	dB(A)	64	65	67
	(*2)	dB(A)	63	64	65
Cabinet	Material	-	Precoated galvanised steel		
	Colour	-	Natural grey (1.0Y 8.5/0.5)		
Unit dimensions	Height	mm	1380		
	Width	mm	1252		
	Depth	mm	370		
Packaging dimensions	Height	mm	1515		
	Width	mm	1312		
	Depth	mm	460		
Packaging volume		m ³	0.91		
Packaging materials		-	Paper + Wood + Plastic		
Net weight		kg	130	135	139
Gross weight		kg	140	145	149
Space heating pipes connection	Connection type	-	Screwed connection		
	Shut-off valves	mm (in.)	G 1-1/4" (male) - G 1-1/4" (male)		
	Inlet pipe diameter	mm (in.)	G 1-1/4" (female)		
	Outlet pipe diameter	mm (in.)	G 1-1/4" (female)		
Working range (Heating)	Outdoor ambient temperature	°C (DB)	-25~25		
	Outlet water temperature	°C	20~60		
Working range (Cooling)	Outdoor ambient temperature	°C (DB)	10~46		
	Outlet water temperature	°C	5~22		
Working range (DHW)	Outdoor ambient temperature	°C (DB)	-25~35		
	Tank water temperature	°C	30~75		
Refrigerant		-	R410A		
Refrigerant charge		kg	2.8	3.1	3.1
Compressor type		-	Scroll DC Inverter driven		

Blank data: To be informed later.

3.3.5 Domestic Hot Water Tank

Model				DHWT-200S-3.0H2E	DHWT-300S-3.0H2E	
Casing	Color			White		
	Material			Polypropylene jacked		
Dimensions	Packing	Height	mm	1300	1880	
		Width	mm	600	600	
		Depth	mm	600	600	
	Unit	Height	mm	1270	1750	
		Width	mm	595	595	
		Depth	mm	595	595	
Weight	Unit		kg	53	63	
	Packed unit		kg	63.5	73	
Packing	Material			EPS		
				CARTON		
	Weight		kg	10.5	11	
Main components	Tank	Water volume	L	194	282	
		Material			Enamelled steel (DIN 4753)	
		Max tank temperature	°C	75	75	
		Max tank water pressure	bar	10	10	
		Max coil water temperature	°C	99	99	
		Max coil water pressure	bar	10	10	
Tank	Insulation	Material			Polyurethane	
		Heat loss (*)	kW·h/day	1.4	1.8	
		Min thickness	mm	50	50	
Main components	Heat exchanger	Quantity			1	1
		Coil surface area	m ²	0.8	0.8	
	Booster heater	Quantity			1	1
		Heater rating	kW	3	3	
	Type			Immersion heater type		
Piping connections	Water inlet domestic connection		inches	¾ (female)		
	Water outlet domestic connection		inches	¾ (female)		
	Recirculation		inches	¾ (female)		
	In coil connection		inches	¾ (female)		
	Out coil connection		inches	¾ (female)		
Thermometer				Yes		
Mechanical thermostat (security)				Yes		
Protection				-		

**NOTE**

- (*) : Heat loss according to DIN-4753/8
- Storage temperature: 65°C
- Ambient temperature: 20°C DB

3.4 Component data

3.4.1 Split system - Outdoor unit

MODEL		RAS-2WHVNP	RAS-2.5WHVNP	RAS-3WHVNP
Air heat exchanger	Type	Multi-pass cross-finned tube		
	Pipe material	Copper		
	Outer diameter	mm	8	
	Rows	2		
	Number of tubes in the heat exchanger	44		
	Fin material	Aluminium		
	Fin pitch	1.45		
	Maximum operating pressure	MPa	4.15	
	Total front area	m ²	0.47	
	Number of heat exchanger per unit	1		
Fan	Fan type	Direct drive propeller fan		
	Fans per unit	1		
	Outer diameter	mm	449	
	Revolutions	rpm	770	850
	Nominal air flow	m ³ /min	41	45
Motor	Shell	Drip-proof type enclosure		
	Starting	Direct current control		
	Power	W	40	
	Quantity	1		
	Insulation class	E		
Compressor	Model	EU1114D9	EU140XA2	2YC45KXD
	Oil Type	HAF68D1 or 68HES-H		FVC50K
	Quantity (l)	0.75		0.80

MODEL		RAS-4WH(V)NPE	RAS-5WH(V)NPE	RAS-6WH(V)NPE	
Air heat exchanger	Type	Multi-pass Cross finned tube			
	Pipe material	Copper			
	Outer diameter	mm	7		
	Rows	2			
	Number of tubes in the heat exchanger	132			
	Fin material	Aluminium			
	Fin pitch	1.4			
	Maximum operating pressure	MPa	4.15		
	Total front area	m ²	1.35		
	Number of heat exchanger per unit	1			
Fan	Fan type	Direct drive propeller fan			
	Fans per unit	2			
	Outer diameter	mm	544		
	Revolutions	rpm	459/376	516/422	573/469
	Nominal air flow	m ³ /min	80	90	100
Motor	Shell	Drip-proof type enclosure			
	Starting	Direct current control			
	Power	W	100 + 100		
	Quantity	2			
	Insulation class	E			
Compressor	Model	E402HHD-36A2 (1~) / E402HHD-36D2 (3N~)			
	Oil type	FVC68D			
	Quantity	0.90			

MODEL		RAS-8WHNPE	RAS-10WHNPE	
Air heat exchanger	Type	Multi-pass cross-finned tube		
	Pipe material	Copper		
	Outer diameter	mm	7	
	Rows	3		
	Number of tubes in the heat exchanger	198		
	Fin material	Aluminium		
	Fin pitch	1.4		
	Maximum Heat exchanger pressure	MPa	4.15	
	Total front area	m ²	1.35	
Number of evaporators per unit	1			
Fan	Fan type	Direct drive propeller fan		
	Fans per unit	2		
	Outer diameter	mm	544	
	Revolutions	rpm	586/717	644/787
	Nominal air flow	m ³ /min	127	134
Motor	Shell	Drip-proof type enclosure		
	Starting	Direct current control		
	Power	W	138 + 138	
	Quantity	2		
	Insulation class	E		
Compressor	Model	DA50PHD-D1SE2	DA65PHD-D1SE2	
	Oil type	FVC68D		
	Quantity	1.90		

3.4.2 Split system - Indoor unit

3.4.2.1 YUTAKI S

Model		RWM-2.0 NE	RWM-2.5 NE	RWM-3.0 NE	RWM-4.0 NE	RWM-5.0 NE	RWM-6.0 NE	RWM-8.0 NE	RWM-10.0 NE		
Water heat exchanger	Type	Brazed plate									
	Material	Stainless steel									
	Transfer fluids	R410A - H ₂ O									
	Quantity	1									
	Internal refrigerant volume	L	0.54	0.73	0.81	1.55	2.09	2.09	3.19	3.91	
	Internal water volume	L	0.57	0.76	0.84	1.64	2.18	2.18	3.28	4.00	
	Insulation material	-	NBR + PVC								
Water pump	Model	-	Yonos PARA RS15/7.0			Yonos PARA RS15/7.5		UPML GEO 25-105			
	Type	-	Inverter								
	Control	-	PWM								
	Power supply	-	1~ 230V 50Hz								
	Maximum lift pressure	kPa	7.2			7.6		10.5			
	Maximum water flow	m ³ /h	3.3			4.0		5.5			
	Maximum power input	W	45			75		140			
	Piping	Water inlet	(in)	G 1"			G 1"		G 1-1/2"		
Water outlet		(in)	G 1"			G 1"		G 1-1/2"			
Inlet/outlet distance		mm	130			130		180			
Water electric heater	Material	-	Stainless steel (Immersion heating element)								
	Power supply	-	1~ 230V 50Hz			1~ 230V 50Hz 3N~ 400V 50Hz		3N~ 400V 50Hz			
	Maximum electric heater power	kW	3.0			6.0		9.0			
	Regulated electric heater power (step 1/ step 2/ step 3)	kW	1.0/2.0/3.0			2.0/4.0/6.0		3.0/6.0/9.0			
	Thermostat security	-	Yes (Cut-out: 90 °C)								
Expansion vessel	Material	-	Steel (with stainless/galvanized steel connections)								
	Internal water volume	L	6.0					10.0			
	Working pressure	MPa	0.3								
	Pre-loading pressure (Air side)	MPa	0.1								
Water strainer	Type	-	Isolated water strainer (Filter ball)								
	Material	-	Brass								
	Piping connection	(in)	1", DN25					1", DN32			
	Mesh (hole size)	mm	0.7								
	Self-cleaning (with back flush) filter	-	Yes								
Safety valve	-	Yes (3 bar)									
Low pressure switch	-	Yes (<0.5 bar)									
Shut-off valve	-	Yes (2 factory-supplied valves)									
Air purger	-	Yes									
Manometer	-	Yes									
Unit controller	-	Yes (PC-ARFHE)									

3.4.2.2 YUTAKI S COMBI

◆ Standard model and UK market model

Model			RWD-2.0NWE-(200/260)S(-K)	RWD-2.5NWE-(200/260)S(-K)	RWD-3.0NWE-(200/260)S(-K)	RWD-4.0NWE-(200/260)S(-K)	RWD-5.0NWE-(200/260)S(-K)	RWD-6.0NWE-(200/260)S(-K)	
Domestic hot water tank	Casing material		Stainless steel						
	Tank	Nominal water volume	L	RWD-NWE-200S(-K): 200 L RWD-NWE-260S(-K): 260 L					
		Net water volume	L	RWD-NWE-200S(-K): 190L RWD-NWE-260S(-K): 250L					
		Material	-	AISI 444					
		Max. water temperature	°C	75					
		Max. water pressure	bar	10					
		Max. heating coil water temperature	°C	75					
		Max. heating coil water pressure	bar	3					
	Tank insulation	Material	-	NEOPOR					
		Thickness	mm	50					
	Heat exchanger	Quantity	-	1					
		Coil surface area	m ²	1.60					
		Internal coil volume	L	20.37					
	Tank's heater	Quantity	-	1					
		Type	-	Immersion heater type					
		Heater rating	kW	2.7					
Mechanical thermostat (adjustable and security)		-	Yes (adjustable 28~80°C ; cut-out: 90°C)						
Water heat exchanger	Type		Brazed plate						
	Material		Stainless steel						
	Transfer fluids		R410A - H ₂ O						
	Quantity		1						
	Internal refrigerant volume	L	0.54	0.73	0.81	1.55	2.09	2.09	
	Internal water volume	L	0.57	0.76	0.84	1.64	2.18	2.18	
	Insulation material		NBR + PVC						
Water pump	Model		Yonos PARA RS15/7.0			Yonos PARA RS15/7.5			
	Type		Inverter						
	Control		PWM						
	Power supply		1~ 230V 50Hz						
	Maximum lift pressure	kPa	7.2			7.6			
	Maximum water flow	m ³ /h	3.3			4.0			
	Maximum power input	W	45			75			
	Piping	Water inlet	(in)	G 1"			G 1"		
Water outlet		(in)	G 1"			G 1"			
Inlet/outlet distance		mm	130			130			

Model			RWD-2.0NWE- (200/260)S(-K)	RWD-2.5NWE- (200/260)S(-K)	RWD-3.0NWE- (200/260)S(-K)	RWD-4.0NWE- (200/260)S(-K)	RWD-5.0NWE- (200/260)S(-K)	RWD-6.0NWE- (200/260)S(-K)
Water electric heater	Material	-	Stainless steel (Immersion heating element)					
	Power supply	-	1~ 230V 50Hz			1~ 230V 50Hz / 3N~ 400V 50Hz		
	Maximum electric heater power	kW	3.0			6.0		
	Regulated electric heater power (step 1/ step 2/ step 3)	kW	1.0/2.0/3.0			2.0/4.0/6.0		
	Thermostat security	-	Yes (Cut-out: 90 °C)					
Expansion vessel	Material	-	Steel (with stainless/galvanized steel connections)					
	Internal water volume	L	6.0					
	Working pressure	MPa	0.3					
	Pre-loading pressure (Air side)	MPa	0.1					
Water strainer	Type	-	Isolated water strainer (Filter ball)					
	Material	-	Brass					
	Piping connection	(in)	1", DN25			1", DN32		
	Mesh (hole size)	mm	0.7					
	Self-cleaning (with back flush) filter	-	Yes					
DHWT Pressure and temperature relief valve (1)	bar		7					
	°C		96					
DHWT thermostat (1)	°C		85					
Safety valve	-		Yes (3 bar)					
Low pressure switch	-		Yes (<0.5 bar)					
Unit drain valve	-		Yes					
DHW drain valve	-		Yes					
Shut-off valve	-		Yes (2 factory-supplied valves)					
Air purger	-		Yes					
Manometer	-		Yes					
Unit controller	-		Yes (PC-ARFHE)					

(1) Only for UK version.

◆ Model for solar combination

Model			RWD-2.0NW(S)E-260S	RWD-2.5NW(S)E-260S	RWD-3.0NW(S)E-260S	RWD-4.0NW(S)E-260S	RWD-5.0NW(S)E-260S	RWD-6.0NW(S)E-260S	
Domestic hot water tank	Casing material		Stainless steel						
	Tank	Nominal water volume	L	RWD-NWE-200S: 200 L RWD-NWE-260S: 260 L					
		Net water volume	L	RWD-NWE-200S: 190L RWD-NWE-260S: 250L					
		Material	-	AISI 444					
		Max. water temperature	°C	75					
		Max. water pressure	bar	10					
		Max. heating coil water temperature	°C	75					
		Max. heating coil water pressure	bar	3					
	Tank insulation	Material	-	NEOPOR					
		Thickness	mm	50					
	Heat exchanger (Heating coil)	Quantity	-	1					
		Coil surface area	m ²	1.60					
		Internal coil volume	L	20.37					
	Heat exchanger (Solar coil)	Quantity	-	1					
		Coil surface area	m ²	0.37					
		Internal coil volume	L	7.90					
	Tank's heater	Quantity	-	1					
		Type	-	Immersion heater type					
		Heater rating	kW	2.7					
	Mechanical thermostat (adjustable and security)		-	Yes (adjustable 28~80°C ; cut-out: 90°C)					
Water heat exchanger	Type	-	Brazed plate						
	Material	-	Stainless steel						
	Transfer fluids	-	R410A - H ₂ O						
	Quantity	-	1						
	Internal refrigerant volume	L	0.54	0.73	0.81	1.55	2.09	2.09	
	Internal water volume	L	0.57	0.76	0.84	1.64	2.18	2.18	
	Insulation material	-	NBR + PVC						
Water pump	Model	-	Yonos PARA RS15/7.0			Yonos PARA RS15/7.5			
	Type	-	Inverter						
	Control	-	PWM						
	Power supply	-	1~ 230V 50Hz						
	Maximum lift pressure	kPa	7.2			7.6			
	Maximum water flow	m ³ /h	3.3			4.0			
	Maximum power input	W	45			75			
	Piping	Water inlet	(in)	G 1"			G 1"		
		Water outlet	(in)	G 1"			G 1"		
Inlet/outlet distance		mm	130			130			

Model		RWD-2.0NW(S)E-260S	RWD-2.5NW(S)E-260S	RWD-3.0NW(S)E-260S	RWD-4.0NW(S)E-260S	RWD-5.0NW(S)E-260S	RWD-6.0NW(S)E-260S
Water electric heater	Material	-	Stainless steel (Immersion heating element)				
	Power supply	-	1~ 230V 50Hz		1~ 230V 50Hz / 3N~ 400V 50Hz		
	Maximum electric heater power	kW	3.0		6.0		
	Regulated electric heater power (step 1/ step 2/ step 3)	kW	1.0/2.0/3.0		2.0/4.0/6.0		
	Thermostat security	-	Yes (Cut-out: 90 °C)				
Expansion vessel	Material	-	Steel (with stainless/galvanized steel connections)				
	Internal water volume	L	6.0				
	Working pressure	MPa	0.3				
	Pre-loading pressure (Air side)	MPa	0.1				
Water strainer	Type	-	Isolated water strainer (Filter ball)				
	Material	-	Brass				
	Piping connection	(in)	1", DN25		1", DN32		
	Mesh (hole size)	mm	0.7				
	Self-cleaning (with back flush) filter	-	Yes				
Safety valve	-	Yes (3 bar)					
Low pressure switch	-	Yes (<0.5 bar)					
Unit drain valve	-	Yes					
DHW drain valve	-	Yes					
Shut-off valve	-	Yes (2 factory-supplied valves)					
Air purger	-	Yes					
Manometer	-	Yes					
Unit controller	-	Yes (PC-ARFHE)					

3.4.2.3 YUTAKI S80

Model			RWH-4.0(V)NF(W)E			RWH-5.0(V)NF(W)E			RWH-6.0(V)NF(W)E			
Compressor	Model	1~ 230V 50Hz	-	H405DHD-64A1			H405DHD-64A1			H405DHD-64A1		
		3N~ 400V 50Hz	-	H405DHD-64D1			H405DHD-64D1			H405DHD-64D1		
	Type		-	Scroll DC Inverter driven								
	Pressure resistance	Discharge	MPa	2.94								
		Suction	MPa	0.15								
	Motor type	Starting method	-	Inverter-driven (I.D.)								
		Poles	-	4								
		Insulation class	-	E								
Oil type		-	FVC68D									
Oil quantity		L	1.2									
Water heat exchanger	Type		Braze plate									
	Material		Stainless steel									
	Transfer fluids	-	R410A H ₂ O	R134a H ₂ O	R410A R134a	R410A H ₂ O	R134a H ₂ O	R410A R134a	R410A H ₂ O	R134a H ₂ O	R410A R134a	
	Quantity	-	1	1	1	1	1	1	1	1	1	
	Internal refrigerant volume	L	1.55	1.55	2.09	2.09	2.09	2.09	2.09	2.09	2.09	
	Internal water volume	L	1.64	1.64	2.18	2.18	2.18	2.18	2.18	2.18	2.18	
	Insulation material		-	NBR + PVC								
Water pump	Model		Yonos PARA RS15/7.5									
	Type		Inverter									
	Control		PWM									
	Power supply		1~ 230V 50Hz									
	Maximum lift pressure	kPa	7.6									
	Maximum water flow	m ³ /h	4.0									
	Maximum power input	W	75									
	Piping	Water inlet	(in)	G 1"								
Water outlet		(in)	G 1"									
Inlet/outlet distance		mm	130									
Expansion vessel	Material		Steel (with stainless/galvanized steel connections)									
	Internal water volume	L	12.0									
	Working pressure	MPa	0.3									
	Pre-loading pressure (Air side)	MPa	0.1									
Water strainer	Type		Isolated water strainer (Filter ball)									
	Material		Brass									
	Piping connection	(in)	1", DN32									
	Mesh (hole size)	mm	0.7									
	Self-cleaning (with back flush) filter		Yes									
Safety valve		-	Yes (3 bar)									
Unit drain valve		-	Yes									
Shut-off valve		-	Yes (2 factory-supplied valves)									
Air purger		-	Yes									
Manometer		-	Yes									
Unit controller		-	No, available as Accessory									

3.4.3 Monobloc system - YUTAKI M

Model		RASM-3VNE	RASM-4(V)NE	RASM-5(V)NE	RASM-6(V)NE	
Compressor	Model	1~ 230V 50Hz	-	2YC45KXD	E402HHD-36A2	
		3N~ 400V 50Hz	-	-	E402HHD-36D2	
	Type	- Scroll DC Inverter driven				
	Pressure resistance	Discharge	MPa	4.15		
		Suction	MPa	2.21		
	Motor type	Starting method	-	Direct current control		
		Poles	-	4		
		Insulation class	-	E		
	Oil type	-	FVC50K	FVC68D		
	Oil quantity	L	0.80	0.90		
Air heat exchanger	Type	- Multi-pass cross-finned tube				
	Pipe material	- Copper				
	Outer diameter	mm	8	7		
	Rows	- 2				
	Number of tubes in the heat exchanger	-	44	132		
	Fin material	- Aluminium				
	Fin pitch	mm	1.4			
	Maximum operating pressure	MPa	4.15			
	Total front area	m ²	0.47	1.35		
	Number of heat exchanger per unit	- 1				
Fan	Fan type	- Direct drive propeller fan				
	Fans per unit	-	1	2		
	Outer diameter	mm	449	544		
	Revolutions	rpm	850	459/376	516/422	573/469
	Nominal air flow	m ³ /min	45	80	90	100
Motor	Type	- Drip-proof type enclosure				
	Starting method	- Direct current control				
	Power	W	40	100 + 100		
	Quantity	-	1	2		
	Insulation class	- E				
Water heat exchanger	Type	- Brazed plate				
	Material	- Stainless steel				
	Transfer fluids	- R410A - H ₂ O				
	Quantity	- 1				
	Internal refrigerant volume	L	0.81	1.55	2.09	2.09
	Internal water volume	L	0.84	1.64	2.18	2.18
	Insulation material	- NBR + PVC				
Water pump	Model	-	Yonos PARA RS15/7.0	Yonos PARA RS15/7.5		
	Type	- Inverter				
	Control	- PWM				
	Power supply	- 1~ 230V 50Hz				
	Maximum lift pressure	kPa	7.2	7.6		
	Maximum water flow	m ³ /h	3.3	4.0		
	Maximum power input	W	45	75		
	Piping	Water inlet	(in)	G 1"		
		Water outlet	(in)	G 1"		
Inlet/outlet distance		mm	130			

Component data

Model		RASM-3VNE	RASM-4(V)NE	RASM-5(V)NE	RASM-6(V)NE
Expansion vessel	Material	-	Stainless steel (Immersion heating element)		
	Internal water volume	L	6.0		
	Working pressure	MPa	0.3		
	Pre-loading pressure (Air side)	MPa	0.1		
Water strainer	Type	-	Isolated water strainer (Filter ball)		
	Material	-	Brass		
	Piping connection	(in)	1", DN25		
	Mesh (hole size)	mm	0.7		
	Self-cleaning (with back flush) filter	-	Yes		
Safety valve	-	Yes (3 bar)			
Shut-off valve	-	No, Supplied as accessory			
Air purger	-	Yes			
Manometer	-	Yes			
Unit controller	-	No, Supplied as accessory			

3.5 Electrical data

3.5.1 Considerations

Key words:

- U: Power supply.
- PH: Phase.
- IPT: Total input power.
- STC: Starting current: Less than maximum current.
- RNC: Running current.
- MC: Maximum current.



NOTE

- *Heating conditions: Inlet/outlet water temperature: 30/35 °C ; Outdoor ambient temperature (DB/WB): 7/6 °C*
- *The compressor data shown in the tables below are based on a combined capacity of 100% of the power supplied.*
- *The "Maximum current" shown in the above table is the maximum total unit running current at the following conditions:*
 - *Supply voltage: 90% of the rated voltage.*
 - *Unit capacity: 100% at maximum operating conditions.*
- *The power supply cables must be sized to cover this maximum current value.*
- *Specifications in these tables are subject to change without notice in order that HITACHI may bring the latest innovations to their customers.*
- ***Please refer to the general information, cautions and notes regarding protective devices (CB, ELB) throughout the "10. Electrical and control settings" chapter.***

3.5.2 Split system - Outdoor unit

RAS-(2-10)WH(V)NP(E) in combination with YUTAKI S, YUTAKI S COMBI

Model	Power supply	Applicable voltage		Compressor and fan motors					MC (A)	Max. IPT (kW)
				Cooling		Heating				
		U max. (V)	U min. (V)	STC (A)	RNC (A)	IPT (KW)	RNC (A)	IPT (KW)		
RAS-2WHVNP	1~ 230V 50Hz	253	207	-	5.2	1.17	3.4	0.77	14	3.14
RAS-2.5WHVNP					6.8	1.54	5.3	1.21	16	3.59
RAS-3WHVNP					9.4	2.14	7.0	1.60	18	4.05
RAS-4WHVNPE					9.2	2.11	9.3	2.12	30	6.93
RAS-5WHVNPE					12.6	2.87	12.7	2.90	30	6.93
RAS-6WHVNPE					16.0	3.65	15.0	3.43	30	6.93
RAS-4WHNPE	3N~ 400V 50Hz	440	360		3.4	2.11	3.4	2.12	14	8.70
RAS-5WHNPE					4.6	2.87	4.6	2.90	14	8.70
RAS-6WHNPE					5.8	3.65	5.5	3.43	16	9.95
RAS-8WHNPE					7.1	4.41	7.3	4.58	24	15.00
RAS-10WHNPE				9.8	6.15	8.8	5.51	24	15.00	

RAS-(4-6)WH(V)NP(E) in combination with YUTAKI S 80

Model	Power supply	Applicable voltage		Compressor and fan motors					MC (A)	Max. IPT (kW)
				Cooling		Heating				
		U max. (V)	U min. (V)	STC (A)	RNC (A)	IPT (KW)	RNC (A)	IPT (KW)		
RAS-4WHVNPE	1~ 230V 50Hz	253	207	-	9.2	2.11	9.3	2.12	20	6.93
RAS-5WHVNPE					12.6	2.87	12.7	2.90	25	6.93
RAS-6WHVNPE					16.0	3.65	15.0	3.43	25	6.93
RAS-4WHNPE	3N~ 400V 50Hz	440	360		3.4	2.11	3.4	2.12	14	8.70
RAS-5WHNPE					4.6	2.87	4.6	2.90	14	8.70
RAS-6WHNPE					5.8	3.65	5.5	3.43	16	9.95

3.5.3 Split system - Indoor unit

3.5.3.1 YUTAKI S

RWM-(2.0-10.0)NE

Model	Power supply	Applicable voltage		Operation mode	RNC (A)	IPT (kW)	MC (A)	Max. IPT (kW)
		U max. (V)	U min. (V)					
RWM-(2.0-3.0)NE	1~ 230V 50Hz	253	207	Without electric heater	0.2	0.05	0.2	0.05
				With electric heater	13.2	3.05	14.5	3.05
				With DHW tank heater	13.2	3.05	14.5	3.05
				With electric and DHW tank heaters	26.3	6.05	28.9	6.05
RWM-(4.0-6.0)NE	1~ 230V 50Hz	253	207	Without electric heater	0.3	0.08	0.3	0.08
				With electric heater	26.4	6.08	29.0	6.08
				With DHW tank heater	13.4	3.08	14.7	3.08
				With electric and DHW tank heaters	39.5	9.08	43.4	9.08
	3N~ 400V 50Hz	440	360	Without electric heater	0.3	0.08	0.3	0.08
				With electric heater	8.8	6.08	9.9	6.08
				With DHW tank heater	4.4	3.08	14.7	3.08
				With electric and DHW tank heaters	13.1	9.08	24.2	9.08
RWM-(8.0/10.0)NE	3N~ 400V 50Hz	440	360	Without electric heater	0.3	0.08	0.6	0.14
				With electric heater	13.1	9.08	14.9	9.14
				With DHW tank heater	4.4	3.08	15.0	3.14
				With electric and DHW tank heaters	17.4	12.08	29.2	12.14

**NOTE**

The data corresponding to DHW tank heater is calculated in combination with the domestic hot water tank accessory "DHWT-(200/300)S-3.0H2E".

3.5.3.2 YUTAKI S COMBI

RWD-(2.0-6.0)NW(S)E-(200/260)S(-K)

Model	Power supply	Applicable voltage		Operation mode	RNC (A)	IPT (kW)	MC (A)	Max. IPT (kW)
		U max. (V)	U min. (V)					
RWD-(2.0-3.0)NW(S)E-(200/260)S(-K)	1~ 230V 50Hz	253	207	Without electric heater	0.2	0.05	0.2	0.05
				With electric heater	13.2	3.05	14.5	3.05
				With DHW tank heater	12.2	2.80	12.7	2.80
				With electric and DHW tank heaters	25.2	5.80	27.0	5.80
RWD-(4.0-6.0)NW(S)E-(200/260)S	1~ 230V 50Hz	253	207	Without electric heater	0.3	0.08	0.3	0.08
				With electric heater	26.4	6.08	29.0	6.08
				With DHW tank heater	12.3	2.83	12.8	2.83
				With electric and DHW tank heaters	38.4	8.83	41.5	8.83
	3N~ 400V 50Hz	440	360	Without electric heater	0.3	0.08	0.3	0.08
				With electric heater	8.8	6.08	9.9	6.08
				With DHW tank heater	4.1	2.83	12.8	2.83
				With electric and DHW tank heaters	12.7	8.83	22.4	8.83

3.5.3.3 YUTAKI S80

◆ Version for indoor unit alone

RWH-(4.0-6.0)(V)NFE

Model	Power supply	Applicable voltage		Operation mode	RNC (A)	IPT (kW)	MC (A)	Max. IPT (kW)
		U max. (V)	U min. (V)					
RWH-4.0VNFE	1~ 230V 50Hz	253	207	Without simultaneous operation of electric heater in DHW tank	12.1	2.73	24	5.33
				With simultaneous operation of electric heater in DHW tank	25.4	5.73	38	8.33
RWH-5.0VNFE				Without simultaneous operation of electric heater in DHW tank	12.3	2.78	28	6.23
				With simultaneous operation of electric heater in DHW tank	25.6	5.78	42	9.23
RWH-6.0VNFE				Without simultaneous operation of electric heater in DHW tank	14.3	3.23	31	6.91
				With simultaneous operation of electric heater in DHW tank	27.6	6.23	45	9.91
RWH-4.0NFE	3N~ 400V 50Hz	440	360	Without simultaneous operation of electric heater in DHW tank	5.6	2.73	10	4.68
				With simultaneous operation of electric heater in DHW tank	11.8	5.73	24	7.68
RWH-5.0NFE				Without simultaneous operation of electric heater in DHW tank	5.7	2.78	10	4.68
				With simultaneous operation of electric heater in DHW tank	11.9	5.78	24	7.68
RWH-6.0NFE				Without simultaneous operation of electric heater in DHW tank	6.7	3.23	10	4.68
				With simultaneous operation of electric heater in DHW tank	12.8	6.23	24	7.68

**NOTE**

The data corresponding to DHW tank heater is calculated in combination with the YUTAKI S80 domestic hot water tank accessory "DHWT-(200/300)S-3.0H2E".

◆ Version for combination with DHW tank

RWH-(4.0-6.0)(V)NFWE + DHWS(200/260)S-2.7H2E

Model	Power supply	Applicable voltage		Operation mode	RNC (A)	IPT (kW)	MC (A)	Max. IPT (kW)
		U max. (V)	U min. (V)					
RWH-4.0VNFWE	1~ 230V 50Hz	253	207	Without simultaneous operation of electric heater in DHW tank	12.1	2.73	24	5.33
				With simultaneous operation of electric heater in DHW tank	24.3	5.48	36	7.94
RWH-5.0VNFWE				Without simultaneous operation of electric heater in DHW tank	12.3	2.78	28	6.23
				With simultaneous operation of electric heater in DHW tank	24.5	5.53	40	8.84
RWH-6.0VNFWE				Without simultaneous operation of electric heater in DHW tank	14.3	3.23	31	6.91
				With simultaneous operation of electric heater in DHW tank	26.5	5.98	43	9.52
RWH-4.0NFWE	3N~ 400V 50Hz	440	360	Without simultaneous operation of electric heater in DHW tank	5.6	2.73	10	4.68
				With simultaneous operation of electric heater in DHW tank	11.3	5.48	22	7.30
RWH-5.0NFWE				Without simultaneous operation of electric heater in DHW tank	5.7	2.78	10	4.68
				With simultaneous operation of electric heater in DHW tank	11.4	5.53	22	7.30
RWH-6.0NFWE				Without simultaneous operation of electric heater in DHW tank	6.7	3.23	10	4.68
				With simultaneous operation of electric heater in DHW tank	12.3	5.98	22	7.30

**NOTE**

The data corresponding to DHW tank heater is calculated in combination with the YUTAKI S80 domestic hot water tank accessory "DHWS(200/260)S-2.7H2E".

◆ Domestic hot water tank

DHWS(200/260)S-2.7H2E

Model	Power supply	Applicable voltage		RNC (A)	IPT (kW)	MC (A)	Max. IPT (kW)
		U max. (V)	U min. (V)				
DHWS200S-2.7H2E	1~ 230V 50Hz	253	207	12.0	2.75	13.2	2.75
DHWS260S-2.7H2E				12.0	2.75	13.2	2.75

3.5.4 Monobloc system - YUTAKI M

RASM-(3-6)(V)NE

Model	Power supply	Applicable voltage		Operation mode	Compressor and fan motors				MC (A)	Max. IPT (kW)		
		U max. (V)	U min. (V)		PH	STC (A)	Heating operation				Cooling operation	
							RNC (A)	IPT (KW)			RNC (A)	IPT (KW)
RASM-3VNE	1~ 230V 50Hz	253	207	Without DHW tank heater	1~	-	7.2	1.65	9.6	2.18	21.6	4.93
With DHW tank heater				19.2			4.40	9.5	2.18	34.1	7.80	
RASM-4VNE				Without DHW tank heater			9.7	2.20	9.6	2.18	30.8	7.01
With DHW tank heater				21.7			4.95	9.6	2.18	43.3	9.88	
RASM-5VNE				Without DHW tank heater			13.1	2.97	13.0	2.95	30.8	7.01
With DHW tank heater				25.1			5.72	12.9	2.95	43.3	9.88	
RASM-6VNE				Without DHW tank heater			15.4	3.50	16.4	3.72	30.8	7.01
With DHW tank heater				27.4			6.25	16.3	3.72	43.3	9.88	
RASM-4NE	3N~ 400V 50Hz	440	360	Without DHW tank heater	3N~	-	3.6	2.20	3.6	2.18	14.3	8.77
With DHW tank heater				11.4			4.95	5.0	2.18	26.8	11.65	
RASM-5NE				Without DHW tank heater			4.8	2.97	4.8	2.95	14.3	8.77
With DHW tank heater				13.2			5.72	6.8	2.95	26.8	11.65	
RASM-6NE				Without DHW tank heater			4.8	2.97	4.8	2.95	16.3	10.02
With DHW tank heater				12.8			5.72	6.6	2.95	28.8	12.90	

**NOTE**

The data corresponding to DHW tank heater is calculated in combination with the domestic hot water tank accessory "DHWT-(200/300)S-3.0H2E".

4 . Capacity and selection data

Index

4.1	System selection procedure	92
4.1.1	Selection parameters	92
4.1.2	Selection procedure	92
4.1.2.1	Description of procedure for YUTAKI S	94
4.1.2.2	Description of procedure for YUTAKI S COMBI.....	100
4.1.2.3	Description of procedure for YUTAKI S 80	107
4.1.2.4	Selection procedure for YUTAKI M units	114
4.1.3	Flow rate and pressure drop check.....	119
4.2	System selection procedure (by Selection Software).....	120
4.2.1	Introduction.....	120
4.2.2	How to use the Selection Software	120
4.3	YUTAKI S	139
4.3.1	Maximum heating capacity table (kW) (Integrated).....	139
4.3.2	Maximum cooling capacity table (kW).....	141
4.4	YUTAKI S COMBI	142
4.4.1	Maximum heating capacity table (kW) (Integrated).....	142
4.4.2	Maximum cooling capacity table (kW)	144
4.5	YUTAKI S 80	145
4.5.1	Maximum heating capacity table (kW) (Integrated).....	145
4.6	YUTAKI M.....	146
4.6.1	Maximum heating capacity table (kW) (Integrated).....	146
4.6.2	Maximum cooling capacity table (kW)	147
4.7	Correction factors.....	148
4.7.1	Piping length correction factor.....	148
4.7.2	Correction factor owing to use of glycol (only for YUTAKI M).....	151

4.1 System selection procedure

The following procedure is an example of selection of YUTAKI system based on previously defined installation requirements: required heating and cooling load, operating temperatures and special characteristics of the installation (energy system used, power source, etc.).

4.1.1 Selection parameters

The tables and graphs shown in this catalogue introduce several parameters used for the selection of YUTAKI units, which are summarised in the following list:

Available models	Maximum capacity in heating (and in cooling, as an option)
General information of the units	COP and EER
Operation space possibilities	Different correction factors
Working range	Sound data for the different units
Available energy systems	



NOTE

- There is a defrost factor included in the Maximum heating capacity tables, as a correction of capacity data for each temperature. Additional calculation due to defrost is not necessary.
- The defrost correction factor corresponds to a relative humidity of 85%. If the condition changes, the correction factor will be different.
- The defrost correction factor is not valid for special conditions such as during snowfall or operation in a transitional period

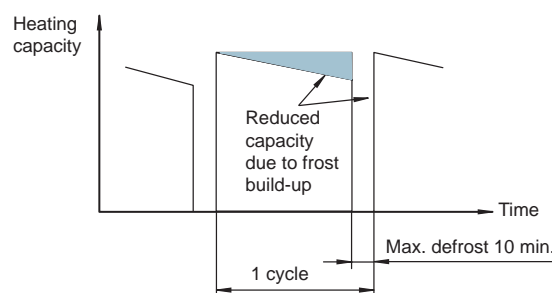

4.1.2 Selection procedure

The system selection procedure is as follows:

A split system with a combination of outdoor unit + indoor unit or a monobloc is preselected first, according to the heating design conditions. Then, the theoretical capacity values taken from the maximum capacity tables are corrected by means of the correction factors, resulting in the actual capacity used to select the system for heating operation.

Next, a suitable DHW tank (200/260 litres) is selected for the production of hot sanitary water, depending on the daily water needs (mandatory for YUTAKI S COMBI, optional as an accessory for YUTAKI S80). Finally, the preselected system combination for heating operation is checked for cooling operation in those models adapted for cooling operation (available as an option for YUTAKI S, YUTAKI S COMBI and YUTAKI M).

The system selection procedure is divided in two parts (heating and cooling) in those models adapted for cooling operation.

◆ Heating mode

Installation configurations

The YUTAKI units are designed to work in monovalent, monoenergetic or bivalent heating systems. They provide efficient control with a reduced energy consumption, while maintaining comfort in the building.

The functionality of a YUTAKI unit depends on the installed components and the selected configuration. It can be configured and upgraded to meet many installation requirements.

A brief description of the three main types of configuration is shown on the next page. These are taken into account in the selection process, in order to provide the best solution for the heating requirements.

Before proceeding to any selection calculation, it must be established whether the designed system is of monovalent, monoenergy or alternating bivalent (boiler only or heater+boiler) type. The capacity-time charts for these main energy systems are shown next.

Monovalent system

The YUTAKI unit is sized to provide 100% of the heating requirements on the coldest days of the year.

Example of monovalent system

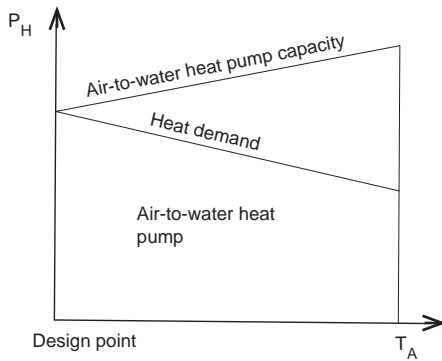

i NOTE

- T_A : Outdoor ambient temperature
- P_H : Heating capacity

Monoenergy system

The YUTAKI unit is sized to provide approximately 80% of the heating requirements on the coldest days of the year. An auxiliary electric heater (mounted on YUTAKI S and YUTAKI S COMBI) is used to provide the additional heating required on cold days.

Example of monoenergy system

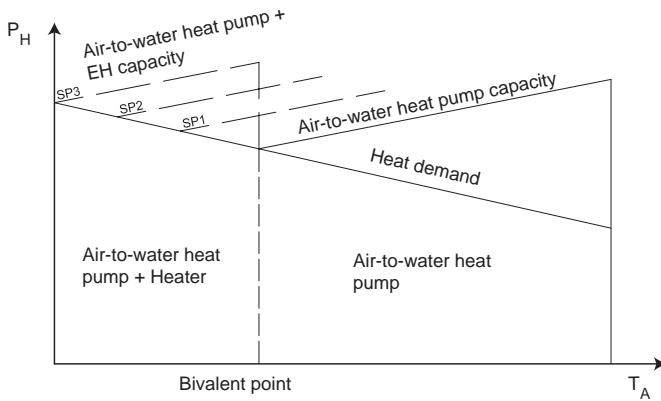

i NOTE

- T_A : Outdoor ambient temperature
- P_H : Heating capacity
- SP1/2/3: Heater steps
- Bivalent point can be set through the user interface of the controller.

Alternating bivalent system

The boiler is configured to alternate operation with the air-to-water heat pump. A hydraulic separator or buffer tank has to be used to ensure hydraulic balancing.

Example of alternating bivalent system (Boiler only)

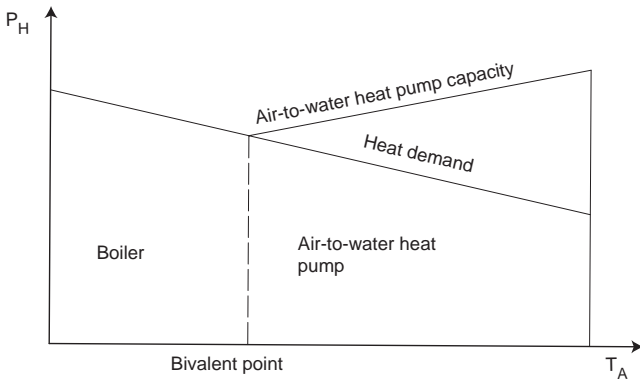

Example of alternating bivalent system (Heater + Boiler)

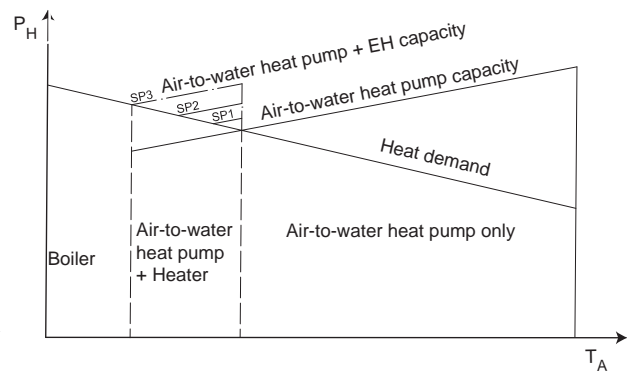

i NOTE

- T_A : Outdoor ambient temperature (°C)
- P_H : Heating capacity
- SP1/2/3: Heater steps
- Bivalent point can be set through the user interface of the controller.



4.1.2.1 Description of procedure for YUTAKI S

The example described in this chapter is based on a monoenergy system, allowing the use of an electrical heater (to cover exceptional heating requirements on the coldest days of the year).

When there is already a conventional boiler (gas/oil) in the installation, it can be used for alternate operation with the YUTAKI S system (electric heater enabled or disabled). This helps to increase the overall performance of the whole installation significantly.

In any case, the calculation example can be applied to all the aforementioned energy systems.

Description of procedure

The selection procedure explained in this chapter is a simple example divided in 3 main blocks:

- a) Choice of the energy system to be used (monoenergy in this case), and selection of the YUTAKI S system depending on the required regular heating load
 - b) Check of the capacity of the selected combination of YUTAKI S and electric heater to cover the exceptional needs of the coldest days of the year
 - c) Selection of the Domestic Hot Water Tank accessory
- a) Selection for a required regular heating load

• Step 1: Initial preselection

Proposed energy system	Monoenergy
Inlet/outlet water temperature	30/35 °C
Regular ambient temperature WB/DB (RH = 85%)	-7/-6 °C
Required regular heating load	9.0 kW
Ambient temperature WB/DB on the coldest day of the year (HR = 85%)	-15/-14.5 °C
Heating load required on the coldest day of the year	12.0 kW

Installation restrictions	
Installation type	Radiant floor
Power supply	1~ 230V 50Hz
Height difference of indoor unit with respect to outdoor unit	15 m lower
Equivalent piping length between outdoor and indoor unit	20 m

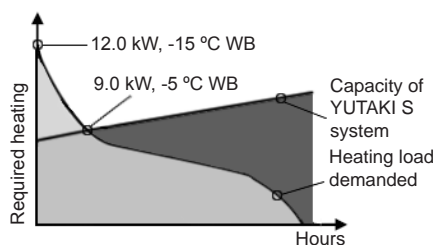

These conditions determine the position in the Maximum heating capacity tables (See section “[4.3.1 Maximum heating capacity table \(kW\) \(Integrated\)](#)”, where it can be confirmed whether the unit has enough heating capacity to cover the regular heating load required by the installation (9.0 kW for an inlet/outlet water temperature of 30/35 °C and an ambient temperature of -7 °C WB).

YUTAKI S system	Maximum heating capacity (kW)
RAS-2WHVNP + RWM-2.0NE	4.70
RAS-2.5WHVNP + RWM-2.5NE	5.70
RAS-3WHVNP + RWM-3.0NE	6.71
RAS-4WHVNPE + RWM-4.0NE	10.62
RAS-5WHVNPE + RWM-5.0NE	12.00
RAS-6WHVNPE + RWM-6.0NE	13.00

The YUTAKI S system that covers the heating requirements of the installation is the combination of RAS-4WHVNPE + RWM-4.0NE. Therefore, this is the preselected YUTAKI S system.

NOTE

In case of working with an ambient temperature value not included in the Maximum heating capacity tables in the “4.3.1 Maximum heating capacity table (kW) (Integrated)” section (for example, -3 °C), interpolation is required using the values above and below the ambient temperature.

• Step 2: Correction of heating capacity for piping length

The actual heating capacity of the preselected unit must be calculated applying the necessary correction factors:

$$Q_H = Q_{MH} \times f_{LH}$$

Q_H : Actual heating capacity (kW)

Q_{MH} : Maximum heating capacity (kW)

f_{LH} : Correction factor for heating piping length

The maximum heating capacity (Q_{MH}) of the RAS-4WHVNPE + RWM-4.0NE system is 10.62 kW.

- Calculation of f_{LH} :

Both the length of the refrigerant piping used and the height difference between the outdoor unit and the indoor unit directly affect the performance of the unit. This concept is quantified by means of the correction factor for piping length.

To determine this value, it is necessary to refer to section “Heating piping length correction factor”. In the example shown in this chapter (equivalent piping length of 20 metres, with the indoor unit placed 15 metres lower than the outdoor unit), the resulting piping length correction factor is **0.992**.

- Calculation of Q_H :

Once the correction factors to be applied have been determined, the formula for actual heating capacity of the RAS-4WHVNPE + RWM-4.0NE system can be applied:

$$Q_H = 10.62 \text{ kW} \times 0.992 = \mathbf{10.53 \text{ kW}}$$

The preselection is valid, since this actual heating capacity is greater than the heating load required by the installation (9.0 kW).

NOTE

If the calculated actual heating capacity is lower than the required regular heating load, the calculation must be done again with the immediately higher unit. If there is no unit higher than the preselected one, some other system (such as combination with boiler) or the regular use of the electric heater should be considered.

b) Selection for the coldest days of the year (use of the auxiliary electric heater)

The previous calculation shows that the RAS-4WHVNPE + RWM-4.0NE system provides a heating capacity of 10.53 kW (-7 °C WB), which is greater than the regular heating load necessary of 9.0 kW, but does not reach the peak heating load of 12.0 kW (-15 °C WB) required for the coldest days of the year. In these cases, the electric heater can provide the auxiliary heating capacity to cover the peak heating load entirely.

The aim of this section is to check that the chosen energy system (Monoenergy) covers the exceptional heating requirements for the coldest days of the year.

- **Step 1: Initial preselection**

As the ambient temperature is lowered to -15 °C, the Maximum heating capacity tables must be consulted again to determine the maximum heating capacity that the RAS-4WHVNPE + RWM-4.0NE system can provide under these new conditions.

The maximum heating capacity for an ambient temperature of -15 °C WB and a water inlet/outlet temperature of 30/35 °C is **9.62 kW**.

- **Step 2: Heating capacity correction for piping length**

The actual heating capacity of the selected system for the coldest days of the year is calculated by applying the correction factors for defrost and piping length, following the previously used method.

$$Q_H = Q_{MH} \times f_{LH}$$

Q_H : **Actual heating capacity (kW)**

Q_{MH} : **Maximum heating capacity (kW)**

f_{LH} : **Heating piping length correction factor**

- Calculation of f_{LH} :

The same correction factor as in the previous section (**0.992**).

- Calculation of Q_H :

Once the corresponding correction factors have been determined, the formula for actual heating capacity of the RAS-4WHVNPE + RWM-4.0NE system can be applied:

$$Q_H = 9.62 \text{ kW} \times 0.992 = \mathbf{9.54 \text{ kW}}$$

• **Step 3: Calculation of the heating capacity for the combination (YUTAKI S system with electric heater)**

Once the corresponding correction factors are applied, the actual heating capacity provided by the RAS-4WHVNPE + RWM-4.0NE system is 9.54 kW. This heating capacity does not cover the required heating load for the coldest days (12.0 kW).

In these cases, the electric heater is to provide the auxiliary capacity required to cover exceptional heating needs.

The electric heater of the RWM-4.0NE unit provides a power of 6 kW, which must be added to the heating capacity provided by the preselected unit. The result is:

$$Q_H = 9.54 \text{ kW} + 6 \text{ kW} = 15.54 \text{ kW}$$

The heating capacity resulting from the addition of the supplementary heating capacity provided by the electric heater is higher than the heating demand of 12.0 kW estimated in this example for the coldest days of the year, so the preselection of the RAS-4WHVNPE + RWM-4.0NE system is considered valid.

The resulting energy system resulting is as follows:

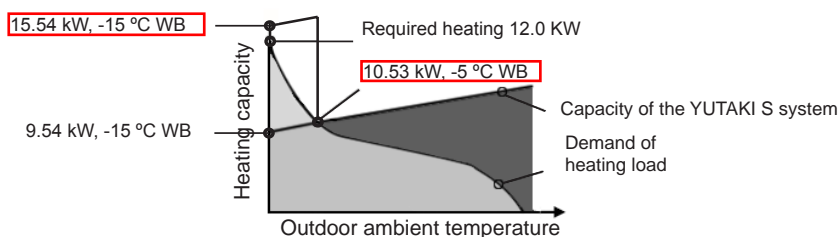

Three-step electric heater control

The heating capacity supplied by the electric heater can be more precisely adjusted by means of the three-step electric heater control. When the electric heater operates in steps 1 or 2, the power input is reduced in comparison with the total power input of the electric heater.

In this example, this option can be applied. The electric heater can operate in step 2 (4 kW), covering the required heating load for the coldest days with a reduction of power input. The result is:

$$Q_H = 9.54 \text{ kW} + 4 \text{ kW} = 13.54 \text{ kW}$$

c) Selection of the domestic hot water tank accessory

The domestic hot water tank accessory corresponding to the selected YUTAKI S system is either DHWT-200S-3.0H2E or DHWT-300S-3.0H2E, depending on the daily water demand and the combination method. The daily water demand is estimated with the following calculation formula for consumption:

$$D_i(T) = D_i(60 \text{ °C}) \times (60 - T_i / T - T_i)$$

Where:

$D_i(T)$: Water demand at T temperature

$D_i(60\text{°C})$: Domestic hot water demand at 60 °C

T : Temperature of the domestic hot water tank

T_i : Temperature of the inlet cold water

- Calculation of $D_i(60 \text{ °C})$:

The standard consumption, expressed in daily litres per person and determined by technical installation regulations of each country, is used to calculate the domestic hot water demand at 60 °C, $D_i(60 \text{ °C})$. This quantity is then multiplied by the expected number of users of the installation. In the following example, the domestic hot water demand at 60 °C has been considered as 30 litres per person, in a detached house with 4 residents (3 bedrooms).

- Calculation of T :

The temperature of the domestic hot water tank refers to the temperature of the accumulated water inside the tank, prior to operation. This temperature is usually between 45 °C and 65 °C. It has been considered as 45 °C in this example.

- Calculation of T_i :

The temperature of the inlet cold water refers to the temperature of the water being supplied to the tank. Since this temperature is usually between 10 °C and 15 °C, it has been considered as 12 °C in this example.

- Example:

$$D_i(T) = 120 \times (60 - 12 / 45 - 12) = 174.6 \text{ litres/day}$$

$$174.6 \times 2(*) = 349.2 \text{ litres/day approximate demand of hot water}$$



NOTE

(*) It is recommended to multiply the calculated consumption by two, in case that the installation is in a detached house. This is done to ensure a steady supply of hot water. In the case of a multifamily installation, it is not necessary to increase the forecast of hot water demand, given the lower simultaneity factor.

Therefore, a 300 litre tank is recommended when the YUTAKI S system is a combination of RAS-4WHVNPE + RWM-4.0NE or higher, in order to ensure a longer supply of hot water and a better system performance. In case that the conditions of demand and the YUTAKI S system are lower than those specifications, a tank with a capacity between 200 litres and 300 litres can be selected, depending on the demand conditions.

A table with the selection of domestic hot water (DHW) tanks recommended by HITACHI for the different existing combinations is shown below:

YUTAKI S system	Domestic hot water tank
RAS-2WHVNP + RWM-2.0NE	DHWT-200S-3.0H2E DHWT-300S-3.0H2E
RAS-2.5WHVNP + RWM-2.5NE	
RAS-3WHVNP + RWM-3.0NE	
RAS-4WH(V)NPE + RWM-4.0NE	DHWT-300S-3.0H2E
RAS-5WH(V)NPE + RWM-5.0NE	
RAS-6WH(V)NPE + RWM-6.0NE	
RAS-8WHNPE + RWM-8.0NE	
RAS-10WHNPE + RWM-10.0NE	



NOTE

- The YUTAKI S system is designed for combination with a HITACHI domestic hot water tank. In case that another tank is being used in combination with a YUTAKI S system, HITACHI cannot guarantee the correct operation or reliability of the system.
- This procedure for selection of a domestic hot water tank is merely illustrative; please refer to the applicable local regulations in order to ensure a proper water demand value.

◆ Cooling mode (as an option, adding the cooling kit accessory and the setting for cooling mode)

Description of the procedure

Upon verification that the selected system is able to cover all the heating needs, it is necessary to perform the same check for cooling mode, in order to obtain the cooling capacity of the system.

- **Step 1: Initial preselection**

Inlet/outlet water temperature	23/18 °C
Ambient temperature DB	30 °C
Required cooling load	14.5 kW

Installation restrictions	
Installation type	Refreshing floor

These conditions determine the position in the Maximum cooling capacity tables (See section “4.3.2 Maximum cooling capacity table (kW)”), where it can be confirmed whether the preselected unit for heating mode can provide the cooling load required by the installation (14.5 kW for an inlet/outlet water temperature of 23/18 °C and an ambient temperature of 30 °C DB).

YUTAKI S system	Maximum cooling capacity (kW)
RAS-4WHVNPE + RWM-4.0NE	15.1

As shown in the table, the RAS-4WHVNPE + RWM-4.0NE system provides a theoretical cooling capacity (15.1 kW) greater than the cooling load required by the installation (14.5 kW). Therefore, the calculation process can continue.

i NOTE

If the unit being preselected for heating mode does not provide the cooling load required by the installation, then preselection shall be changed by choosing the immediately higher unit.

- **Step 2: Correction of cooling capacity for piping length**

The actual cooling capacity of the preselected unit must be calculated applying the necessary correction factors:

$$Q_c = Q_{MC} \times f_{LC}$$

Q_c : Actual cooling capacity (kW)

Q_{MC} : Maximum cooling capacity (kW)

f_{LC} : Correction factor for cooling piping length

The maximum cooling capacity (Q_{MC}) of the RAS-4WHVNPE + RWM-4.0NE system is 15.1 kW.

- Calculation of f_{LC} :

To determine this value, it is necessary to refer to section “Cooling piping length correction factor”. In the example shown in this chapter (equivalent piping length of 20 metres, with the indoor unit placed 15 metres lower than the outdoor unit), the resulting piping length correction factor is **0.978**, approximately.

- Calculation of Q_c :

Once the correction factors to be applied have been determined, the formula for actual cooling capacity of the RAS-4WHVNPE + RWM-4.0NE system can be applied:

$$Q_c = 15.1 \text{ kW} \times 0.978 = \mathbf{14.76 \text{ kW}}$$

The actual cooling capacity of the RAS-4WHVNPE + RWM-4.0NE system (14.76 kW) is greater than the cooling load required by the installation (14.5 kW). Therefore, the preselection is considered valid for both heating and cooling.

i NOTE

If the calculated actual cooling capacity is lower than that provided by the preselected unit, the calculation must be done again with the immediately higher unit.

4.1.2.2 Description of procedure for YUTAKI S COMBI

The following selection procedure is described in this chapter:

- a. Selection of system combination (outdoor unit + indoor unit)
 - i. Without heating source (monovalent system)
 - ii. With additional heating source (monoenergy / bivalent system)
- b. Selection of the capacity of the domestic hot water tank (200/260 litres).

**NOTE**

The following selection procedure is the same in the case of YUTAKI S COMBI for solar combination and YUTAKI S COMBI for UK-marked models.

a.i) Monovalent system (regular selection)

In the case of normal selection of monovalent system (without additional heating sources), the YUTAKI S COMBI is selected depending on the required heating load.

**NOTE**

The example given in this chapter is the regular selection, as the YUTAKI S COMBI has been designed to cover all the heating requirements, even on the coldest days of the year.

- **Step 1: Initial preselection**

Proposed energy system	Monovalent
Inlet/outlet water temperature	30/35 °C
Ambient temperature WB/DB on the coldest day of the year (RH = 85%)	-2/-1 °C
Heating load required on the coldest day of the year	11.0 kW

Installation restrictions	
Installation type	Radiant floor
Power supply	1~ 230 V 50 Hz
Height difference of indoor unit with respect to outdoor unit	15 m lower
Equivalent piping length between outdoor and indoor unit	20 m

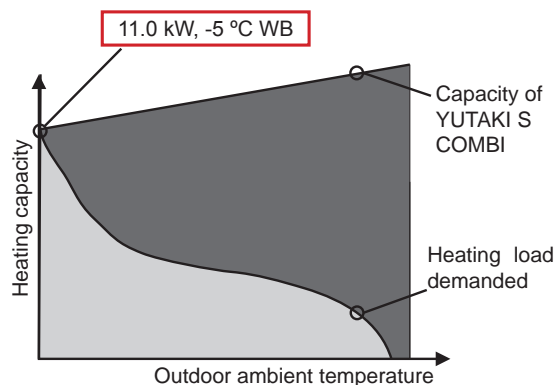

These conditions determine the position in the Maximum heating capacity tables (see section "4.4.1 Maximum heating capacity table (kW) (Integrated)", where it can be confirmed whether the unit has enough heating capacity to cover the heating load required by the installation on the coldest day of the year (11.0 kW for an inlet/outlet water temperature of 30/35 °C and an ambient temperature of -2 °C WB).

YUTAKI S COMBI System	Maximum heating capacity (kW)
RAS-2WHVNP + RWD-2.0NWE-(200/300)S	5.16
RAS-2.5WHVNP + RWD-2.5NWE-(200/300)S	6.40
RAS-3WHVNP + RWD-3.0NWE-(200/300)S	7.92
RAS-4WHVNPE + RWD-4.0NWE-(200/300)S	11.83
RAS-5WHVNPE + RWD-5.0NWE-(200/300)S	13.10
RAS-6WHVNPE + RWD-6.0NWE-(200/300)S	14.06

The YUTAKI S COMBI system that covers the heating requirements of the installation is the combination of RAS-4WHVNPE + RWD-4.0NWE-(200/300)S. Therefore, this becomes the preselected YUTAKI S COMBI system.

**NOTE**

In case of working with an ambient temperature value not included in the Maximum heating capacity tables in the “4.4.1 Maximum heating capacity table (kW) (Integrated)” section (for example, -3 °C), interpolation is required using the values above and below the ambient temperature.

- **Step 2: Heating capacity correction for piping length**

The actual heating capacity of the preselected unit must be calculated applying the necessary correction factors:

$$Q_H = Q_{MH} \times f_{LH}$$

Q_H : Actual heating capacity (kW)

Q_{MH} : Maximum heating capacity (kW)

f_{LH} : Heating piping length correction factor

The maximum heating capacity (Q_{MH}) of the RAS-4WHVNPE + RWD-4.0NWE-(200/300)S system is 11.83 kW.

- Calculation of f_{LH} :

Both the length of the refrigerant piping used and the height difference between the outdoor unit and the indoor unit directly affect the performance of the unit. This concept is quantified by means of the correction factor for piping length.

To determine this value, it is necessary to refer to section “Heating piping length correction factor”. In the example shown in this chapter (equivalent piping length of 20 metres, with the indoor unit placed 15 metres lower than the outdoor unit), the resulting piping length correction factor is **0.988**.

- Calculation of Q_H :

Once the correction factors to be applied have been determined, the formula for actual heating capacity of the RAS-4WHVNPE + RWD-4.0NWE-(200/300)S system can be applied:

$$Q_H = 11.83 \text{ kW} \times 0.988 = 11.68 \text{ kW}$$

The preselection is valid, since the actual heating capacity of the RAS-4WHVNPE + RWD-4.0NWE-(200/300)S system (11.68 kW) is greater than the heating load required by the installation (11.0 kW).

**NOTE**

If the calculated actual heating capacity is lower than the required heating load, the calculation must be done again with the immediately higher unit. If there is no unit higher than the preselected one, some other system (such as combination with boiler or electric heater accessory) should be considered.

a.ii) Use of auxiliary heating source (combination with electric heater or boiler)

When there is already a conventional boiler (gas/oil) in the installation, it can be used for alternate operation with the YUTAKI S COMBI (bivalent system). This helps to increase the overall performance of the whole installation significantly.

The indoor unit has also a built-in electric heater which can provide the additional heat load if required (monoenergy system).

In any case, the previous description of procedure can be applied to all the aforementioned energy systems, but including a heat load check when using an auxiliary heating source (monoenergy or bivalent systems) and recalculating the new heating points.

It is verified whether the combination (YUTAKI S COMBI + electric heater / boiler) covers the exceptional needs on the coldest days of the year.

Monoenergy and bivalent systems are useful when there is a constant regular heating load with short periods of heating load peaks occurring on the coldest days of the year.

**NOTE**

The following check can be used equally for both of the combinations.

Step 1: Initial preselection

Proposed energy system	Monoenergy
Inlet/outlet water temperature	30/35 °C
Regular ambient temperature WB/DB (RH = 85%)	2/3 °C
Required regular heating load	9.0 kW
Ambient temperature WB/DB on the coldest day of the year (RH = 85%)	-7/-6 °C
Heating load required on the coldest day of the year	11.0 kW

Installation restrictions	
Installation type	Radiant floor
Power supply	1~ 230 V 50 Hz
Height difference of indoor unit with respect to outdoor unit	15 m lower
Equivalent piping length between outdoor and indoor unit	20 m

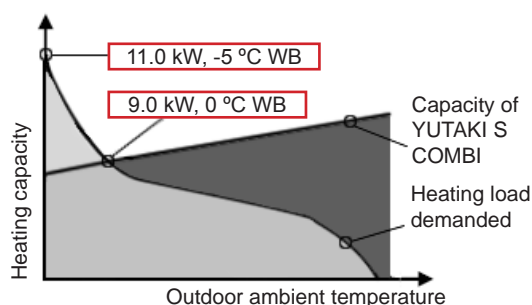

In this new system, the heat pump meets the regular heating load. The electric heater can provide the auxiliary heating capacity required to cover the peak heating load of 11.0 kW (-7 °C WB) on the coldest days of the year.



NOTE

Even though the RAS-3WHVNP + RWD-3.0NWE-(200/300)S combination has a slightly lower maximum heating capacity than required heating load, it cannot be selected since capacity becomes lower after the application of correction factors. Therefore, the immediately higher combination is taken.

YUTAKI S COMBI System	Maximum heating capacity (kW)
RAS-2WHVNP + RWD-2.0NWE-(200/300)S	5.50
RAS-2.5WHVNP + RWD-2.5NWE-(200/300)S	7.00
RAS-3WHVNP + RWD-3.0NWE-(200/300)S	8.90
RAS-4WHVNPE + RWD-4.0NWE-(200/300)S	12.80
RAS-5WHVNPE + RWD-5.0NWE-(200/300)S	13.90
RAS-6WHVNPE + RWD-6.0NWE-(200/300)S	15.00

The maximum heating capacity of this new system for an ambient temperature of 2 °C WB and a water inlet/outlet temperature of 30/35 °C is 12.8 kW. The result of applying the heating piping length correction factor of 0.988, just like in point a.i), is:

$$Q_H = 12.8 \text{ kW} \times 0.988 = \mathbf{12.64 \text{ kW}}$$

The heating capacity of the new system for the conditions of the coldest days (-7 °C WB) has to be calculated with the help of the Maximum heating capacity tables.

The maximum heating capacity for an ambient temperature of -7 °C WB and a water inlet/outlet temperature of 30/35 °C is 10.62 kW.

• Step 2: Heating capacity correction for piping length

The actual heating capacity of the selected system for the coldest days of the year is calculated by applying the correction factors for piping length, following the previously used method.

$$Q_H = Q_{MH} \times f_{LH}$$

Q_H : Actual heating capacity (kW)

Q_{MH} : Maximum heating capacity (kW)

f_{LH} : Heating piping length correction factor

- Calculation of f_{LH} :

The resulting piping length correction factor is **0.988**.

- Calculation of Q_H :

Once the corresponding correction factors have been determined, the formula for actual heating capacity of the RAS-4WHVNPE + RWD-4.0NWE-(200/300)S system can be applied:

$$Q_H = 10.62 \times 0.988 = 10.49 \text{ kW}$$

• Step 3: Calculation for the heating capacity of the combination (YUTAKI S COMBI with electric heater)

Once the corresponding correction factors are applied, the actual heating capacity provided by the RAS-4WHVNPE + RWD-4.0NWE-(200/300)S system on the coldest days is 9.84 kW. This heating capacity does not cover the required heating load for the coldest days (10.49 kW).

In these cases, the built-in electric heater in the YUTAKI S COMBI indoor unit is to provide the auxiliary capacity required to cover exceptional heating needs.

This electric heater provides a maximum power of 6.0 kW for this unit, which must be added to the heating capacity provided by the preselected unit. The result is:

$$Q_H = 10.49 \text{ kW} + 6 \text{ kW} = 16.49 \text{ kW}$$

In this example, the resulting heating capacity is higher than the heating demand of 11.0 kW estimated for the coldest days of the year, so the preselection of the RAS-4WHVNPE + RWD-4.0NWE-(200/300)S system is considered valid.

The resulting energy system is as follows:

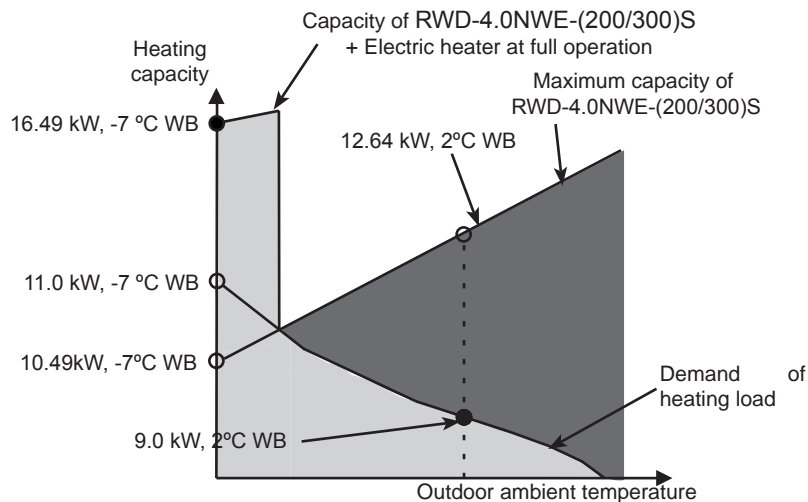

Three-step electric heater control

The heating capacity supplied by the electric heater can be more precisely adjusted by means of the three-step electric heater control. When the electric heater operates in steps 1 or 2, the power input is reduced in comparison with the total power input of the electric heater.

In this example, this option can be applied. The electric heater can operate in step 1 (2.0 kW), covering the required heating load for the coldest days with a reduction of power input. The result is:

$$Q_H = 10.49 \text{ kW} + 2.0 \text{ kW} = 12.49 \text{ kW}$$

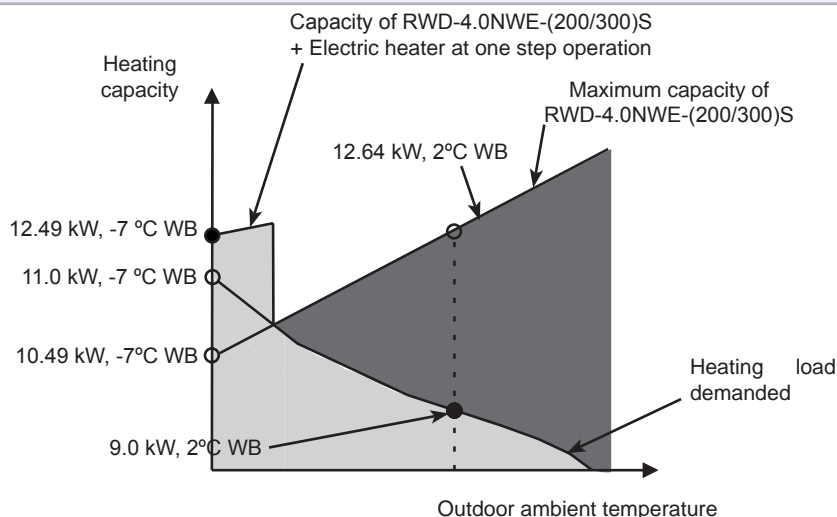

b) Selection of the domestic hot water tank

Two different DHW tank models, with respective capacities of 200 and 260 litres, can be selected according to the water demand. In order to determine the suitable tank size it is necessary to estimate the daily water demand, using the following calculation formula for consumption:

$$D_i(T) = D_i(60^\circ\text{C}) \times (60 - T_i / T - T_i)$$

Where:

- $D_i(T)$: Water demand at T temperature
- $D_i(60^\circ\text{C})$: Domestic hot water demand at 60°C
- T : Temperature of the domestic hot water tank
- T_i : Temperature of the inlet cold water

- Calculation of $D_i(60^\circ\text{C})$:

The standard consumption, expressed in daily litres per person and determined by technical installation regulations of each country, is used to calculate the domestic hot water demand at 60°C , $D_i(60^\circ\text{C})$. This quantity is then multiplied by the expected number of users of the installation. In the following example, the domestic hot water demand at 60°C has been considered as 30 litres per person, in a detached house with 4 residents (3 bedrooms).

- Calculation of T :

The temperature of the domestic hot water tank is an estimation referred to the temperature of the accumulated water inside the tank, prior to operation. This temperature is usually between 45°C and 65°C . It has been considered as 45°C in this example.

- Calculation of T_i :

The temperature of the inlet cold water refers to the temperature of the water being supplied to the tank. Since this temperature is usually between 10°C and 15°C , $T_i = 12^\circ\text{C}$ is used in this example to calculate an approximate water demand.

- Example:

$$D_i(T) = 120 \times (60 - 12 / 45 - 12) = 174.6 \text{ litres/day (*)}$$



NOTE

(*): Different strategies of accumulation can be applied, depending on the electric tariff, the installation space and the cost/efficiency relation. In case that a low-cost electric tariff strategy is selected (accumulation strategy), the daily water demand could double that of the normal case (semi accumulation strategy).

The election of the water tank depends on the following table:

Daily water demand	Size of domestic hot water tank
Less than 185 litres	RWD-(2.0-6.0)NWE-200S
More than 185 litres	RWD-(2.0-6.0)NWE-260S



NOTE

- The storage capacity of the tank has to be adjusted to daily consumption in order to avoid stagnation of water.
- This procedure for selection of a domestic hot water tank is merely illustrative; please refer to the applicable local regulations in order to ensure a proper water demand value.

◆ Cooling mode (as an option, adding the cooling kit accessory and the setting for cooling mode)

Description of the procedure

Upon verification that the selected system (monoenergy) is able to cover all the heating needs, it is necessary to perform the same check for cooling mode, in order to obtain the cooling capacity of the system.

• Step 1: Initial preselection

Inlet/outlet water temperature	23/18 °C
Ambient temperature DB	30 °C
Required cooling load	14.5 kW

Installation restrictions	
Installation type	Refreshing floor

These conditions determine the position in the Maximum cooling capacity tables (See section [“4.4.2 Maximum cooling capacity table \(kW\)”](#)), where it can be confirmed whether the unit preselected for heating mode has enough can provide the cooling load required by the installation (14.5 kW for an inlet/outlet water temperature of 23/18 °C and an ambient temperature of 30 °C DB).

YUTAKI S COMBI system	Maximum cooling capacity (kW)
RAS-4WHVNPE + RWD-4.0NWE-200S	15.1

The RAS-4WHVNPE + RWD-4.0NWE-200S system provides a theoretical cooling capacity (15.1 kW) greater than the cooling load required by the installation (14.5 kW). Therefore, the calculation process can continue.



NOTE

If the unit being preselected for heating mode does not provide the cooling load required by the installation, the preselection should be changed by choosing the immediately higher unit.

- **Step 2: Cooling capacity correction for defrost and piping length**

The actual cooling capacity of the preselected unit is calculated by applying the necessary correction factors:

$$Q_c = Q_{MC} \times f_{LC}$$

Q_c : **Actual cooling capacity (kW)**

Q_{MC} : **Maximum cooling capacity (kW)**

f_{LC} : **Cooling piping length correction factor**

The maximum cooling capacity (Q_{MC}) of the RAS-4WHVNPE + RWD-4.0NWE-200S system is 15.1 kW.

- Calculation of f_{LC} :

To determine this value, it is necessary to refer to section “*Cooling piping length correction factor*”. In the example shown in this chapter (equivalent piping length of 20 metres, with the indoor unit placed 15 metres lower than the outdoor unit), the resulting piping length correction factor is **0.978** approximately.

- Calculation of Q_c :

Once the correction factors to be applied have been determined, the formula for actual cooling capacity of the RAS-4WHVNPE + RWD-4.0NWE-200S system can be applied:

$$Q_c = 15.1 \text{ kW} \times 0.978 = \mathbf{14.76 \text{ kW}}$$

The preselection is valid both for heating and cooling, since the actual cooling capacity of the RAS-4WHVNPE + RWD-4.0NWE-200S system (11.25 kW) is greater than the cooling load required by the installation (14.5 kW).



NOTE

If the calculated actual cooling capacity is lower than that provided by the preselected unit, the calculation must be done again with the immediately higher unit.

4.1.2.3 Description of procedure for YUTAKI S 80

The following selection procedure is described in this chapter:

- c. Selection of system combination (outdoor unit + indoor unit)
 - i. Without heating source (monovalent system)
 - ii. With additional heating source (monoenergy / bivalent system)
- a. Selection of the capacity of the domestic hot water tank accessory (optional).

a.i) Monovalent system (regular selection)

In the case of normal selection of monovalent system (without additional heating sources), the YUTAKI S80 is selected depending on the required heating load.



NOTE

The example given in this chapter is the regular selection as the YUTAKI S80 has been designed to cover all the heating requirements, even on the coldest days of the year.

• **Step 1: Initial preselection**

Proposed energy system	Monovalent
Inlet/outlet water temperature	47/55°C
Ambient temperature WB/DB in the coldest day of the year (RH = 85%)	-7/-6°C
Heating load required on the coldest day of the year	13.5 kW

Installation restrictions	
Installation type	Radiant floor
Power supply	1~ 230V 50Hz
Height difference of indoor unit with respect to outdoor unit	15 m or lower
Equivalent piping length between outdoor and indoor unit	20 m

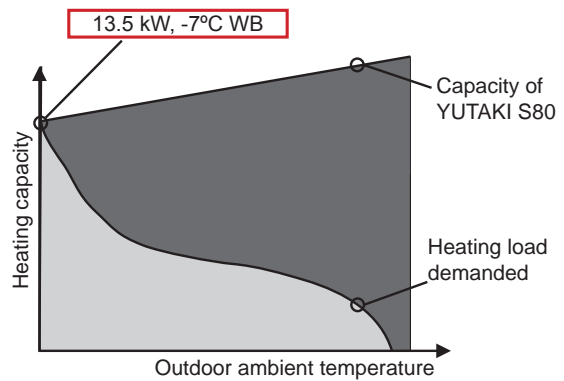

These conditions determine the position in the Maximum heating capacity tables (see section “4.5.1 Maximum heating capacity table (kW) (Integrated)”), where it can be confirmed whether the unit has enough heating capacity to cover the heating load required by the installation on the coldest day of the year (13.5 kW for an inlet/outlet water temperature of 47/55 °C and an ambient temperature of -7 °C WB).

YUTAKI S80	Maximum heating capacity (kW)
RAS-4WHVNPE + RWH-4.0VNF(W)E	12.50
RAS-5WHVNPE + RWH-5.0VNF(W)E	14.50
RAS-6WHVNPE + RWH-6.0VNF(W)E	16.10



NOTE

Even though the RAS-4WHVNPE + RWH-4.0VNF(W)E combination has a slightly higher maximum heating capacity than the required heating load, it is necessary to select the immediately higher combination since heating capacity becomes lower after applying the correction factors in step 2.

According to the table, the YUTAKI S80 system that covers the heating requirements of the installation is the combination of RAS-5WHVNPE + RWH-5.0VNF(W)E. Therefore, this becomes the preselected YUTAKI S80 system.

**NOTE**

In case of working with an ambient temperature value not included in the Maximum heating capacity tables in the “4.5.1 Maximum heating capacity table (kW) (Integrated)” section (for example, -3°C), interpolation is required using the values above and below the ambient temperature.

- **Step 2: Correction of heating capacity for piping length**

The actual heating capacity of the preselected unit must be calculated applying the necessary correction factors:

$$Q_H = Q_{MH} \times f_{LH}$$

Q_H : Actual heating capacity (kW)

Q_{MH} : Maximum heating capacity (kW)

f_{LH} : Correction factor for heating piping length

The maximum heating capacity (Q_{MH}) of the RAS-5WHVNPE + RWH-5.0VNF(W)E system is 14.50 kW.

- Calculation of f_{LH} :

Both the length of the refrigerant piping used and the height difference between the outdoor unit and the indoor unit directly affect the performance of the unit. This concept is quantified by means of the correction factor for piping length.

To determine this value, it is necessary to refer to section “Heating piping length correction factor”. In the example shown in this chapter (equivalent piping length of 20 metres, with the indoor unit placed 15 metres lower than the outdoor unit), the resulting piping length correction factor is **0.988**.

- Calculation of Q_H :

Once the correction factors to be applied have been determined, the formula for actual heating capacity of the RAS-5WHVNPE + RWH-5.0VNF(W)E system can be applied:

$$Q_H = 14.50 \text{ kW} \times 0.988 = \mathbf{14.33 \text{ kW}}$$

The preselection is valid, since the actual heating capacity of the RAS-5WHVNPE + RWH-5.0VNF(W)E system (14.33 kW) is greater than the heating load required by the installation (13.5 kW).

**NOTE**

If the calculated actual heating capacity is lower than the required heating load, the calculation must be done again with the immediately higher unit. If there is no unit higher than the preselected one, some other system (such as combination with boiler or electric heater accessory) should be considered.

a.ii) Use of auxiliary heating source (combination with electric heater or boiler)

When there is already a conventional boiler (gas/oil) in the installation, it can be used for alternate operation with the YUTAKI S80 (bivalent system). This helps to increase the overall performance of the whole installation significantly.

An electric heater can also be installed as an accessory for the monoenergy system, if an additional heat load is required.

In any case, the previous description of procedure can be applied to all the aforementioned energy systems, but including a heat load check when using an auxiliary heating source (monoenergy or bivalent systems) and recalculating the new heating points.

It is verified whether the combination (YUTAKI S80 + electric heater / boiler) covers the exceptional needs on the coldest days of the year.

Monoenergy and bivalent systems are useful when there is a constant regular heating load with short periods of heating load peaks occurring on the coldest days of the year.

**NOTE**

The following check can be used equally for both of the combinations.

• **Step 1: Initial preselection**

Proposed energy system	Monoenergy
Inlet/outlet water temperature	47/55 °C
Regular ambient temperature WB/DB (RH = 85%)	2/3 °C
Required regular heating load	10.0 kW
Ambient temperature WB/DB on the coldest day of the year (RH = 85%)	-7/-6 °C
Heating load required on the coldest day of the year	13.5 kW

Installation restrictions	
Installation type	Radiant floor
Power supply	1~ 230V 50Hz
Height difference of Indoor unit with respect to outdoor unit	15 m lower
Equivalent piping length between outdoor and indoor unit	20 m

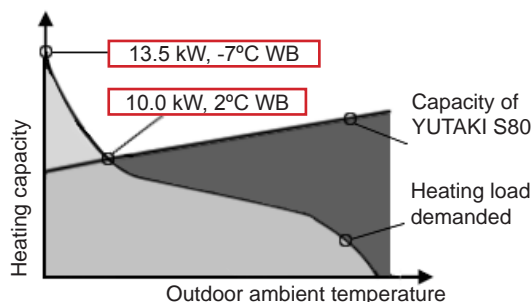

In this new system, the heat pump meets the regular heating load. The electric heater can provide the auxiliary heating capacity required to cover the peak heating load of 13.5 kW (-7 °C WB) on the coldest days of the year.

As the heating load has been lowered to 10.0 kW, with this point being taken as the regular heating load, it is possible to reselect the required unit. The RAS-5WHVNPE + RWH-5.0VNF(W)E system would provide too much heating capacity, while the RAS-4WHVNPE + RWH-4.0VNF(W)E system is suited for these new conditions.

YUTAKI S80	Maximum heating capacity (kW)
RAS-4WHVNPE + RWH-4.0VNF(W)E	13.54
RAS-5WHVNPE + RWH-5.0VNF(W)E	15.70
RAS-6WHVNPE + RWH-6.0VNF(W)E	16.30

The maximum heating capacity of this new system for an ambient temperature of 2 °C WB and a water inlet/outlet temperature of 47/55 °C is **13.54 kW**. The result of applying the heating piping correction factor of 0.988, just like in point a.i), is:

$$Q_H = 13.54 \text{ kW} \times 0.988 = 13.38 \text{ kW}$$

The heating capacity of the new system for the conditions of the coldest days (-7 °C) has to be calculated with the help of the Maximum heating capacity tables.

The maximum heating capacity for an ambient temperature of -7°C WB and a water inlet/outlet temperature of 47/55 °C is **12.5 kW**.



• Step 2: Heating capacity correction for piping length

The actual heating capacity of the selected system for the coldest days of the year is calculated by applying the correction factors for piping length, following the previously used method.

$$Q_H = Q_{MH} \times f_{LH}$$

Q_H : Actual heating capacity (kW)

Q_{MH} : Maximum heating capacity (kW)

f_{LH} : Heating piping length correction factor

- Calculation of f_{LH} :

The resulting piping length correction factor is **0.988**.

- Calculation of Q_H :

Once the corresponding correction factors have been determined, the formula for actual heating capacity of the RAS-4WHVNPE + RWH-4.0VNF(W)E system can be applied:

$$Q_H = 12.5 \text{ kW} \times 0.988 = 12.35 \text{ kW}$$

• Step 3: Calculation for the heating capacity of the combination (YUTAKI S80 with electric heater)

Once the corresponding correction factors are applied, the actual heating capacity provided by the RAS-4WHVNPE + RWH-4.0VNF(W)E system is 12.35 kW. This heating capacity does not cover the required heating load for the coldest days (13.5 kW).

In these cases, the electric water heater supplied by HITACHI as an accessory (WEH-6E) is to provide the auxiliary capacity required to cover exceptional heating needs.

The auxiliary electric heater provides a maximum power of 6.0 kW, which must be added to the heating capacity provided by the preselected unit. The result is:

$$Q_H = 12.35 \text{ kW} + 6 \text{ kW} = 18.35 \text{ kW}$$

In this example, the resulting heating capacity is higher than the heating demand of 13.0 kW estimated for the coldest days of the year, so the preselection of the RAS-4WHVNPE + RWH-4.0VNF(W)E system is considered valid.

The resulting energy system is as follows:

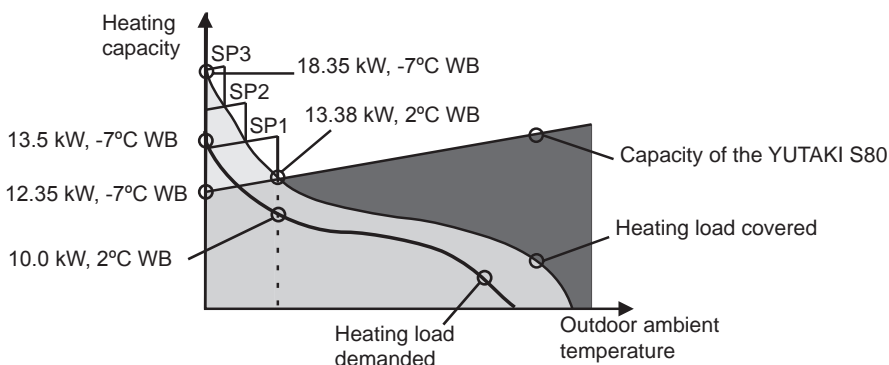

Three-step electric heater control

The desired heating capacity provided by the electric heater can be more precisely adjusted by means of the three-step electric heater control. When the electric heater operates in steps 1 or 2, the power input is reduced in comparison with the total power input of the electric heater.

In this example, this option can be applied. The electric heater can operate in step 1 (2.0 kW), covering the required heating load for the coldest days with a reduction of power input. The result is:

$$Q_H = 12.35 \text{ kW} + 2.0 \text{ kW} = 14.35 \text{ kW}$$

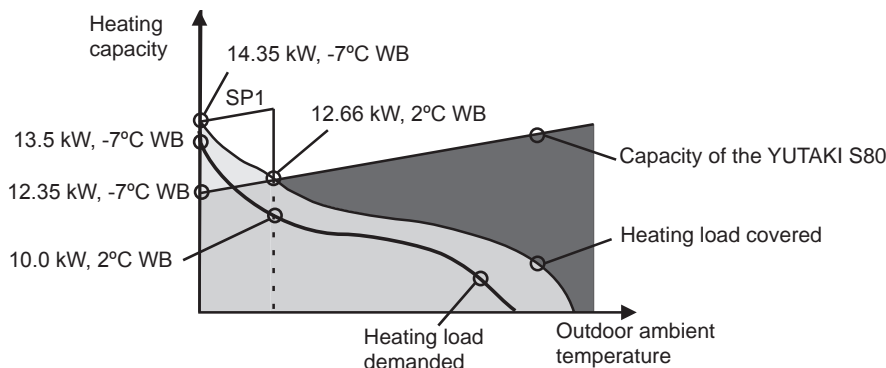

b) Selection of the domestic hot water tank accessory (only for RWH-(4.0-6.0)(V)NFE series)

The domestic hot water tank accessory applicable to the YUTAKI S80 system (RWH-(4.0-6.0)(V)NFE series) is the DH-WS200S-2.7H2E or DHWS260S-2.7H2E, depending on the daily water demand and the combination method. The daily water demand is estimated with the following calculation formula for consumption.

$$D_i(T) = D_i(60^\circ\text{C}) \times (60 - T_i / T - T_i)$$

Where:

- $D_i(T)$: Water demand at T temperature
 $D_i(60^\circ\text{C})$: Domestic hot water demand at 60°C
 T : Domestic hot water tank's temperature
 T_i : Inlet cold water temperature

- Calculation of $D_i(60^\circ\text{C})$:

The standard consumption, expressed in daily litres per person and determined by technical installation regulations of each country, is used to calculate the domestic hot water demand at 60°C , $D_i(60^\circ\text{C})$. This quantity is then multiplied by the expected number of users of the installation. In the following example, the domestic hot water demand at 60°C has been considered as 30 litres per person, in a detached house with 4 residents (3 bedrooms).

- Calculation of T :

The temperature of the domestic hot water tank is an estimation referred to the temperature of the accumulated water inside the tank, prior to operation. This temperature is usually between 45°C and 65°C . It has been considered as 45°C in this example.

- Calculation of T_i :

The temperature of the inlet cold water refers to the temperature of the water being supplied to the tank. The usual range of cold water temperature is between 10°C and 15°C . 12°C is used in this example to calculate an approximate water demand.

- Example:

$$D_i(T) = 120 \times (60 - 12 / 45 - 12) = 174.6 \text{ litres/day (*)}$$



NOTE

(*): Different strategies of accumulation can be applied, depending on the electric tariff, the installation space and the cost/efficiency relation. In case that a low-cost electric tariff strategy is selected (accumulation strategy), the daily water demand could double that of the normal case (semi accumulation strategy).

The election of the water tank depends on the following table:

Daily water demand	Size of domestic hot water tank
Less than 185 litres	DHWS200S-2.7H2E
More than 185 litres	DHWS260S-2.7H2E

YUTAKI S80 system	Domestic hot water tank
RAS-4WH(V)NPE + RWH-4.0(V)NFE RAS-5WH(V)NPE + RWH-5.0(V)NFE RAS-6WH(V)NPE + RWH-6.0(V)NFE	DHWS200S-2.7H2E DHWS260S-2.7H2E



NOTE

- The storage capacity of the tank has to be adjusted to daily consumption in order to avoid stagnation of water.
- The YUTAKI S80 is designed to be used in combination with a HITACHI domestic hot water tank. In case that another tank is being used in combination with YUTAKI S80, HITACHI cannot guarantee the proper operation or reliability of the system.
- This procedure for selection of a domestic hot water tank is merely illustrative; please refer to the applicable local regulations in order to ensure a proper water demand value.

b) Selection of the domestic hot water tank accessory (only for RWH-(4.0-6.0)(V)NFE series)

The domestic hot water tank accessory corresponding to the YUTAKI S80 system (RWH-(4.0-6.0)(V)NFE series) is either DHWT-200S-3.0H2E or DHWT-300S-3.0H2E, depending on the water demand and the combination method. The daily water demand is estimated with the following calculation formula for consumption:

$$D_i(T) = D_i(60^\circ\text{C}) \times (60 - T_i / T - T_i)$$

Where:

- $D_i(T)$:** Water demand at T temperature
 $D_i(60^\circ\text{C})$: Domestic hot water demand at 60°C
 T : Temperature of the domestic hot water tank
 T_i : Temperature of the inlet cold water

- Calculation of **$D_i(60^\circ\text{C})$** :

The standard consumption, expressed in daily litres per person and determined by technical installation regulations of each country, is used to calculate the domestic hot water demand at 60°C , **$D_i(60^\circ\text{C})$** . This quantity is then multiplied by the expected number of users of the installation. In the following example, the domestic hot water demand at 60°C has been considered as 30 litres per person, in a detached house with 4 residents (3 bedrooms).

- Calculation of **T** :

The temperature of the domestic hot water tank is an estimation referred to the temperature of the accumulated water inside the tank, prior to operation. This temperature is usually between 45°C and 65°C . It has been considered as 45°C in this example.

- Calculation of **T_i** :

The temperature of the inlet cold water refers to the temperature of the water being supplied to the tank. The temperature of cold water is in the range between 10°C and 15°C . 12°C is used in this example to calculate an approximate water demand.

- Example:

$$D_i(T) = 120 \times (60 - 12 / 45 - 12) = 174.6 \text{ litres/day}$$

$$174.6 \times 2(*) = 349.2 \text{ litres/day approximate demand of hot water}$$

i NOTE

(*) It is recommended to multiply the calculated consumption by two, in case that the installation is in a detached house. This is done to ensure a steady supply of hot water. In the case of a multifamily installation, it is not necessary to increase the forecast of hot water demand, given the lower simultaneity factor.

Therefore, a 300 litre tank is recommended when the system is a combination of RAS-4WHVNPE + RWH-4.0VNFE or higher, in order to ensure a longer supply of hot water and a better system performance. In case that the conditions of demand are lower than those specifications, a tank with a capacity of 200 litres can be selected, depending on the demand conditions. A table with the selection of domestic hot water (DHW) tanks recommended by HITACHI for the different existing combinations is shown below:

YUTAKI S 80 system	Domestic hot water tank
RAS-4WH(V)NPE + RWH-4.0(V)NFE	DHWT-300S-3.0H2E
RAS-5WH(V)NPE + RWH-5.0(V)NFE	
RAS-6WH(V)NPE + RWH-6.0(V)NFE	

i NOTE

- The YUTAKI S80 system is designed for combination with a HITACHI domestic hot water tank. In case that another tank is being used in combination with a YUTAKI S80 system, HITACHI cannot guarantee the correct operation or reliability of the system.
- This procedure for selection of a domestic hot water tank is merely illustrative; please refer to the applicable local regulations in order to ensure a proper water demand value.

4.1.2.4 Selection procedure for YUTAKI M units

The selection procedure explained in this chapter is a simple example structured into three main blocks:

- a) Choice of the energy system to be used (monoenergy in this case), and selection of a YUTAKI M unit depending on the normal heating load
- b) Check to ensure that the combination (YUTAKI M + electric heater) covers the exceptional needs of the coldest days of the year
- c) Selection of the domestic hot water tank accessory

- a) Selection for a regular heating load

• **Step 1: Initial preselection**

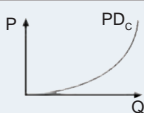
Proposed energy system	Monoenergetic
Regular ambient temperature WB/DB (RH = 85%)	-7/-6 °C
Required regular heating load	10.5 kW
Ambient temperature WB/DB on the coldest day of the year (RH = 85%)	-15 / -14.5 °C
Heating load required on the coldest day of the year	13.5 kW
Inlet/outlet water temperature	40 / 45 °C
Power supply	1~ 230V 50Hz
Type of glycol to use	Ethylene
Pressure loss on the client's hydraulic installation (PD _C)	

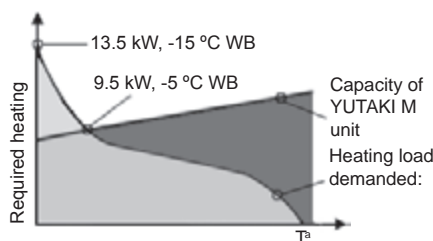

These conditions determine the position in the table of “4.6.1 Maximum heating capacity table (kW) (Integrated)” section, where it can be confirmed whether the unit has enough heating capacity to cover the regular heating load required by the installation (10.5 kW for an inlet/outlet water temperature of 40/45 °C and an ambient temperature of -7°C WB).

YUTAKI M Unit	Maximum heating capacity (kW)
RASM-3VNE	6.40
RASM-4VNE	10.00
RASM-5VNE	11.60
RASM-6VNE	12.50

According to the table, the YUTAKI M unit that covers the heating requirements of the installation is the RASM-5VNE. Therefore, this becomes the preselected unit.

NOTE

In case of working with an ambient temperature value not included in the tables of “4.6.1 Maximum heating capacity table (kW) (Integrated)” (for example, -3°C), interpolation is required using the values above and below the ambient temperature.

- **Step 2: Heating capacity correction for use of glycol**

The actual heating capacity of the preselected unit must be calculated applying the necessary correction factors:

$$Q_h = Q_{Mh} \times f_{gh}$$

Q_h : Actual heating capacity (kW)

Q_{Mh} : Maximum heating capacity (kW)

f_{gh} : Capacity correction factor owing to use of glycol

The maximum heating capacity (Q_{Mh}) of the RHUE-5AVHN-HM unit is 11.60 kW.

- Calculation of f_{gh} :

The unit may be damaged by water freezing in the pipes during shutdown periods, under low ambient temperatures in winter. An antifreeze mixture with glycol is used to prevent this.

On the other hand, the percentage of glycol used may affect the heating capacity of the unit.

To calculate the capacity correction factor due to the use of glycol, please refer to the [“4.7.2 Correction factor owing to use of glycol \(only for YUTAKI M\)”](#) section, bearing in mind the type of glycol to be used. In this example, ethylene is used.

The ambient temperature value of -4 °C DB does not appear in the table. Therefore, the percentage of ethylene glycol to be used corresponds to the immediately lower ambient temperature in the table. In this case, it is -7 °C.

At this ambient temperature, the necessary percentage of ethylene glycol is 20%, for which the corresponding capacity correction factor owing to the use of ethylene glycol of **1**.

- Calculation of Q_h :

Once the correction factors to be applied have been determined, the formula for actual heating capacity of the unit RHUE-5AVHN-HM can be applied:

$$Q_h = 11.3 \text{ kW} \times 1 = \mathbf{11.3 \text{ kW}}$$

The preselection of the RASM-5VNE unit is valid, since its actual heating capacity (11.3 kW) is greater than the heating load required by the installation (10.5 kW).

i NOTE

If the calculated actual heating capacity is lower than that provided by the preselected unit, the calculation must be done again with the immediately higher unit. If there is no unit higher than the preselected one, some other system or the regular use of an electric heater should be considered.

b) Selection for the coldest days of the year (use of the auxiliary electric heater)

The previous calculation shows that the RASM-5VNE unit provides a heating capacity of 13.3 kW (-7 °C WB), which is greater than the regular heating load necessary of 10.5 kW, but does not reach the peak heating load of 13.5 kW (-15 °C WB) necessary on the coldest days of the year. The auxiliary electric heater is used in these cases.

The aim of this section is to check that the energy system chosen (combination of the YUTAKI M unit + auxiliary electric heater) covers the temporary heating requirements for the coldest days of the year.

- **Step 1: Initial preselection**

As the ambient temperature is lowered to -15 °C, the capacity tables in the [“Maximum heating capacity table”](#) section must be consulted again to determine the maximum heating capacity that the RASM-5VNE unit can provide under these new conditions.

The maximum heating capacity for an ambient temperature of -15 °C WB and a water inlet/outlet temperature of 40/45 °C is **9.43 kW**.

• Step 2: Correction of the heating capacity owing to the use of glycol

The actual heating capacity of the selected unit for the coldest days of the year is calculated by applying correction factors for defrosting and glycol, following the previously used method.

$$Q_h = Q_{Mh} \times f_{gh}$$

Q_h : Actual heating capacity (kW)

Q_{Mh} : Maximum heating capacity (kW)

f_d : Defrosting correction factor

f_{gh} : Capacity correction factor owing to use of glycol

- Calculation of f_{gh} :

The ambient temperature value of -14.5 °C DB does not appear in the tables in “4.7.2 Correction factor owing to use of glycol (only for YUTAKI M)” section. Therefore, the percentage of ethylene glycol to use corresponds to the immediately lower ambient temperature in the table. In this case, it is -22 °C.

At this ambient temperature, the necessary percentage of ethylene glycol is 40%, for which there is a corresponding capacity correction factor, owing to the use of ethylene glycol, of **0.99**.

- Calculation of Q_h :

Once the correction factors to be applied have been determined, the formula for actual heating capacity of the RHUE-5AVHN-HM unit can be applied:

$$Q_h = 9.43 \text{ kW} \times 0.99 = \mathbf{9.33 \text{ kW}}$$

• Step 3: Calculation for the heating capacity of the combination (YUTAKI M unit + electric heater)

Once the corresponding correction factors are applied, the actual heating capacity provided by the RASM-5VNE unit is 9.33 kW. This heating capacity does not cover the required heating load for the coldest days (13.5 kW).

In these cases, the electric water heater supplied by HITACHI as an accessory (WEH-6E) is to provide the auxiliary capacity required to cover exceptional heating needs.

The electric heater offered by HITACHI as an accessory provides a power of 6 kW, which must be added to the heating capacity provided by the preselected unit. The result is:

$$Q_h = 9.33 \text{ kW} + 6 \text{ kW} = 15.33 \text{ kW}$$



NOTE

The heating capacity resulting from the combination (YUTAKI M unit + electric heater) is higher than the heating demand of 13.5 kW estimated in this example for the coldest days of the year, and so the preselection of the RHUE-5AVHN-HM unit is considered valid.

The resulting energy system is as follows:

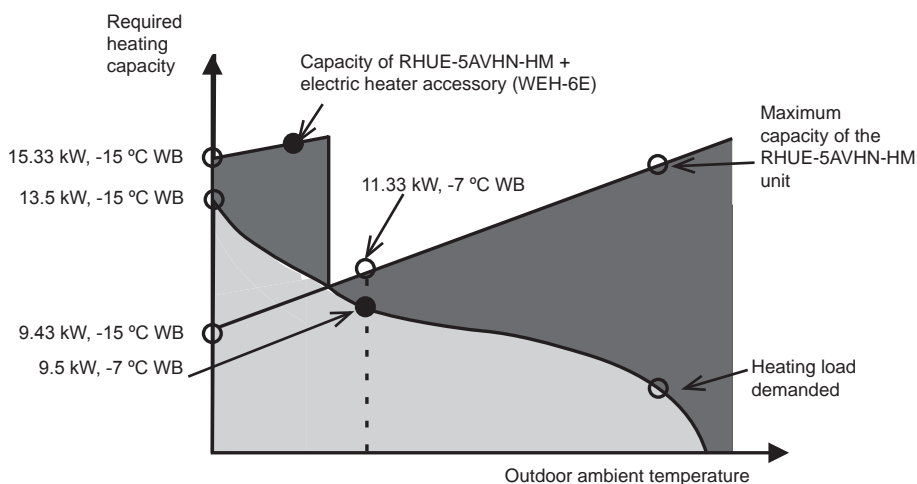

c) Selection of the domestic hot water tank accessory

The domestic hot water tank accessory corresponding to the selected YUTAKI M system is either DHWT-200S-3.0H2E or DHWT-300S-3.0H2E, depending on the water demand and the combination method. The daily water demand is estimated with the following calculation formula for consumption:

$$D_i(T) = D_i(60^{\circ}\text{C}) \times (60 - T_i / T - T_i)$$

Where:

$D_i(T)$: **Water demand at T temperature**

$D_i(60^{\circ}\text{C})$: **Domestic hot water demand at 60 °C**

T : **Temperature of the domestic hot water tank**

T_i : **Temperature of the inlet cold water**

- Calculation of $D_i(60^{\circ}\text{C})$:

The standard consumption, expressed in daily litres per person and determined by technical installation regulations of each country, is used to calculate the domestic hot water demand at 60 °C, $D_i(60^{\circ}\text{C})$. This quantity is then multiplied by the expected number of users in the installation. In the following example, the domestic hot water demand at 60 °C has been considered as 30 litres per person, in a detached house with 4 residents (3 bedrooms).

- Calculation of T :

The temperature of the domestic hot water tank is an estimation referred to the temperature of the accumulated water inside the tank, prior to operation. The temperature is usually in the range between 45 °C and 65 °C. It has been considered as 45 °C in this example.

- Calculation of T_i :

The temperature of the inlet cold water refers to the temperature of the water being supplied to the tank. This temperature is in the range between 10 °C and 15 °C. 12 °C is used in this example to calculate an approximate water demand.

- Example:

$$D_i(T) = 120 \times (60 - 12 / 45 - 12) = 174.6 \text{ litres/day}$$

$$174.6 \times 2 (*) = 349.2 \text{ litres/day approximate demand of hot water}$$

NOTE

(*) It is recommended to multiply the calculated consumption by two, in case that the installation is in a detached house. This is done to ensure a steady supply of hot water. In the case of a multifamily installation, it is not necessary to increase the forecast of hot water demand, given the lower simultaneity factor.

Therefore, a 300 litre tank is recommended when the system is a combination with RASM-4VNE or higher, in order to ensure a longer supply of hot water and a better system performance. In case that the conditions of demand are lower than those specifications, a tank with a capacity 200 litres can be selected, depending on the demand conditions. A table with the selection of domestic hot water (DHW) tanks recommended by HITACHI for the different existing combinations is shown below:

YUTAKI M system	Domestic hot water tank
RASM-3VNE	DHWT-200S-3.0H2E DHWT-300S-3.0H2E
RASM-4(V)NE	DHWT-300S-3.0H2E
RASM-5(V)NE	
RASM-6(V)NE	

NOTE

- The YUTAKI S80 system is designed for combination with a HITACHI domestic hot water tank. In case that another tank is being used in combination with a YUTAKI S80 system, HITACHI cannot guarantee the proper operation or reliability of the system.
- This procedure for selection of a domestic hot water tank is merely illustrative; please refer to the applicable local regulations in order to ensure a proper water demand value.

- ◆ Cooling mode (as an option, adding the cooling kit accessory and the setting for cooling mode)

Procedure description

Upon verification that the selected system (monoenergy) is able to cover all the heating needs, it is necessary to perform the same check for cooling mode, in order to obtain the cooling capacity of the system.

- **Step 1: Initial preselection**

Inlet/outlet water temperature	23/18 °C
Ambient temperature DB	35 °C
Required cooling load	14.5 kW

Installation restrictions	
Installation type	Refreshing floor

These conditions determine the position in the Maximum cooling capacity tables, (See section “4.6.2 Maximum cooling capacity table (kW)”), where it can be confirmed whether the preselected unit for heating mode can provide the cooling load required by the installation (10.5 kW for an inlet/outlet water temperature of 23/18 °C and an ambient temperature of 30 °C DB).

YUTAKI S COMBI system	Maximum cooling capacity (kW)
RASM-5VNE	16.0

The RASM-5VNE system provides a theoretical cooling capacity (16.0 kW) greater than the cooling load required by the installation (10.5 kW). Therefore, the calculation process can continue.



NOTE

If the unit being preselected for heating mode does not provide the cooling load required by the installation, then preselection shall be changed by choosing the immediately higher unit.

- **Step 2: Correction of cooling capacity for defrost and piping length**

The actual cooling capacity of the preselected unit must be calculated applying the necessary correction factors:

$$Q_c = Q_{MC} \times f_{LC}$$

Q_c : Actual cooling capacity (kW)

Q_{MC} : Maximum cooling capacity (kW)

f_{LC} : Correction factor for cooling piping length

The maximum cooling capacity (Q_{MC}) of the RASM-5VNE system is 16.0 kW.

- Calculation of f_{LC} :

To determine this value, it is necessary to refer to section “Cooling piping length correction factor”. In the example shown in this chapter (equivalent piping length of 20 metres, with the indoor unit placed 15 metres lower than the outdoor unit), the resulting correction factor for cooling piping length becomes **0.976**, approximately.

- Calculation of Q_c :

Once the correction factors to be applied have been determined, the formula for actual cooling capacity of the RAS-4WHVNPE + RWD-4.0NWE-200S system can be applied:

$$Q_c = 16.0 \text{ kW} \times 0.976 = \mathbf{15.62 \text{ kW}}$$

The actual cooling capacity of the RAS-4WHVNPE + RWD-4.0NWE-200S system (15.62 kW) is greater than the cooling load required by the installation (14.5 kW). Therefore, the preselection is considered valid for both heating and cooling.

**NOTE**

If the calculated actual cooling capacity is lower than that provided by the preselected unit, the calculation must be done again with the immediately higher unit.

4.1.3 Flow rate and pressure drop check

Step 1: Calculation of the flow rate required for the circulation pump

The following formula is used to calculate the required pumping flow in order to provide a heating capacity, producing an increase in the difference of temperature between water inlet and water outlet, depending on the requested heating capacity.

$$CFR = \frac{Q_h \times f_{gf} \times 860}{1000 \times (T_S - T_E)}$$

CFR: Calculated flow rate (m³/h)

Q_h: Actual heating capacity (kW)

f_{gf}: Correction factor of flow rate owing to use of glycol

(T_S - T_E): Difference in temperature between water inlet and water outlet (°C)

**NOTE**

Calculation of f_{gf}: Once the actual heating capacity and the difference between the water inlet and water outlet temperatures are known, the value required to calculate the pump flow rate is the flow correction factor due to the use of glycol f_{gf}. The use of glycol affects the actual heating capacity, since the density of glycol is higher than that of water. Therefore, a higher flow rate is necessary for the same conditions. To calculate the flow rate correction factor owing to the use of glycol, please see the table in section "4.7.2 Correction factor owing to use of glycol (only for YUTAKI M)", bearing in mind the type of glycol used.

- **Step 2: Verification of the working limits of the flow on the water circulating pump**

Once the flow needed for the pump has been determined, it must be verified whether it lies within the working limits of the unit. Refer to the "6. Working range" chapter, where the maximum and minimum flow for each YUTAKI unit can be found.

- **Step 3: Calculation of the necessary pressure to be provided by the circulating pump**

The circulating pump must be able to provide the pressure required to make up for the pressure loss in the hydraulic unit installation at the client's side, working with the previously calculated flow.

The section "Pump performance curves" contains operation details of the YUTAKI models. The data needed are the pressure losses from the hydraulic unit installation at the client's side and have been estimated as given by the following formula:

$$P = K \times Q^2$$

P = Loss of pressure on the client's hydraulic installation (mH₂O)

Q = Pump flow rate of circulating water (m³/h)

K = Coefficient depending on the characteristics of the hydraulic installation (diameter and length of pipes, roughness, etc.).

Check whether the selected units cover the pressure drop for the circulating flow rate in the "Pump performance curves" section, and install an additional pump in the client's hydraulic installation if necessary.

**CAUTION**

The use of glycol affects the reading of some parameters like "water flow level" and "capacity" shown through the unit controller menu. When glycol is used, these data are not correct and must be not used.

4.2 System selection procedure (by Selection Software)

4.2.1 Introduction

Hi-ToolKit for Home is a HITACHI software product that has been especially designed for professionals working in the field of individual home heating.

More than just a software product used for selecting air-to-water heat pumps, Hi-ToolKit for Home is a genuine technical and financial tool. In just a few clicks, Hi-ToolKit for Home allows the creation of a general technical and financial proposal for an end-user customer, which can be used as a complement to a quote issued by a professional.

Hi-ToolKit for Home software guarantees the selection that best fits the customer's needs, among HITACHI heat pumps.

It is already available in all hardware platforms (PC, Smartphone, Tablets).



4.2.2 How to use the Selection Software

The following is a brief explanation on the usage of the Hi-ToolKit software. The contents are common for the entire range of YUTAKI units from HITACHI (YUTAKI S, YUTAKI S COMBI, YUTAKI S80 and YUTAKI M).

The Hi-ToolKit software is an online web application, which can be used in all major computer platforms (Windows, MacOS, Linux), without the need to install any piece of software. The most popular web browsers are supported on their latest versions.

The Selection Software can be accessed from any of the following URLs:

<http://hitachi-hitoolkit.com/heating/users/login>

<http://www.hi-toolkit.com/forhome/>

◆ Main screen

<p>The first time that Hi-ToolKit for Home software is used, it is necessary to register by entering an e-mail and password.</p>	<p>The screenshot shows the main screen of the Hi-ToolKit software. At the top, there is a navigation bar with 'Hi-ToolKit' and 'HITACHI' logos. Below the navigation bar is a large image of a modern interior with a staircase. Underneath the image is a 'Sign in' section with input fields for 'Email' and 'Password', a 'Remember me' checkbox, and 'Sign In' and 'Register' buttons. A 'Forgot your password?' link is also present.</p>
--	---

◆ Register

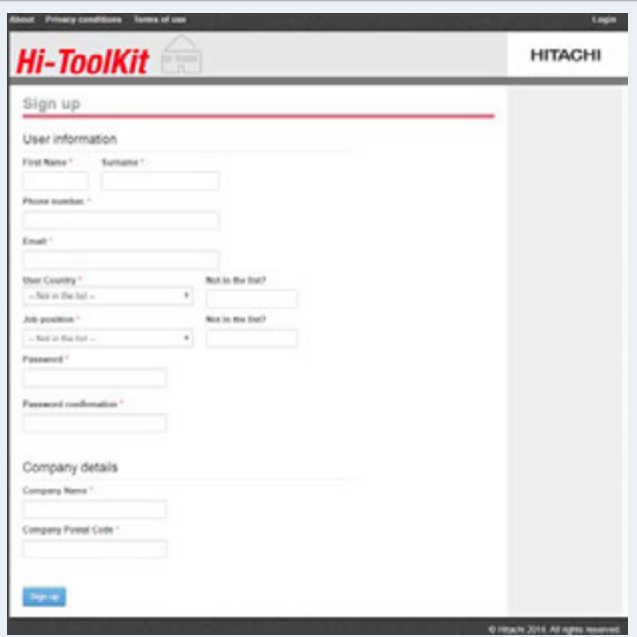
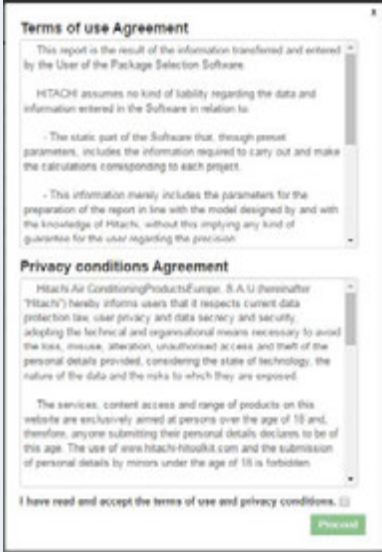
<p>Complete all user information, and after completes, click “Sign up” and you will be prompted to accept the “terms and conditions”.</p>	
<p>The “Terms of Service Agreement” appear when new user has been registered. It shows the general conditions of using the software.</p> <p>Please read and understand prior to accept these conditions.</p> <p>To continue to the following steps, accept the conditions and click Proceed.</p>	
<p>When the conditions are accepted, Hi-toolkit platform sends a confirmation mail to the new user.</p> <p>Click to “Confirm my account”</p>	<p>Welcome no-reply@hitachi-hitoolkit.com</p> <p>Confirm the account email through the received link: Confirm my account</p>



◆ Main tab

After Register & Log-in screens, Hi-tool kit main screen is shown.

In the first starting, it can be selected one of the following list of options:

- Start new project: This will take you to create a completely new project
- Import project: This will open a existing project created out of the user.
- My preferences: This opens the setting preferences for the user (and it will be used for all projects)

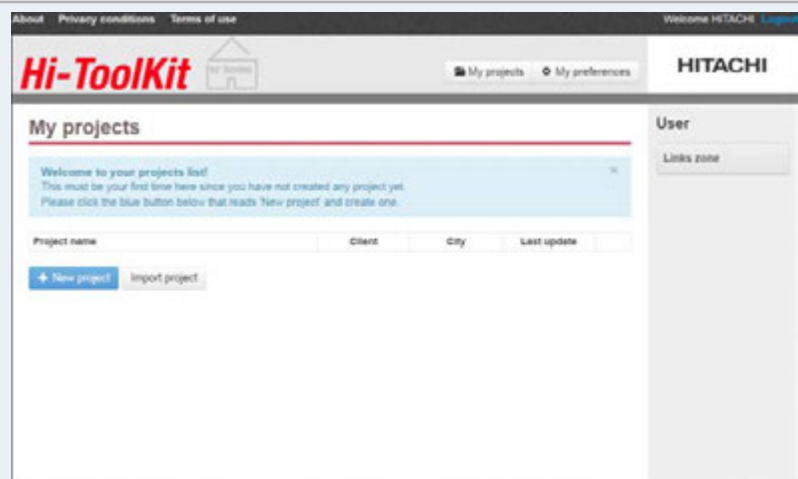

◆ My preferences

The “My Preferences” screen consists of several options, to define various settings that apply to all Hi-toolKit projects. “My Preferences” has been created in two parts:

- 1 Installation preferences: All options related with installations issues. Use of the room thermostat, price of the units, price of electricity, gas, fuel...
- 2 User preferences: All options related with user issues. Different unit measures, change software language, setting of the user...

1. Installation preferences

Room thermostat

Hi-Toolkit selection software assumes that design room temperature is 21°C, however Room thermostat can be selected.

YUTAKI room thermostat has weekly timer function in order to change automatically the setting room temperature. This value is taken into account in the calculation.

Default value is the factory default setting.

Unit prices list

Defines the prices of the all units supplied by HITACHI that are possible to use with HI-toolkit for Home.

Here, the price of the different units can be introduced, and it will be shown after in the final report.

It is possible to enter a price list file by using IMPORT button or export price list file by using EXPORT button.



Energy Configuration - Electricity Price (1)

Connection cost: Corresponding price of electricity connection (is not used for calculation).

CO2 emission factor: Corresponding CO2 emissions factor by using electricity.

Tariff: The electricity price for the projects can be selected between high prices, medium and low price per kWh.

- Low tariff (Price per kWh): Price of electricity by using low tariff application.
- Medium tariff (Price per kWh): Price of electricity by using medium tariff application.
- High tariff (Price per kWh): Price of electricity by using high tariff application.

The "Restore to Default" button returns to the original values for HI-toolKit software.

Energy Configuration - Electricity Price (2)

Electricity tariff schedule: allows to make a schedule to apply a tariff for every hour of every day of the week.

Select the hour/s and day/s and apply the tariff clicking in the appropriate button of tariff (Set low/medium/high Tariff)

If you click on the hour cell, is selected the same hour for all the days of the week.

If you click day, is selected all hours of the selected day.

In the example, the three tariff conditions (low/medium/high) are shown for

- Low tariff:
00h~04h & 22h~23h
- Medium tariff:
05h & 11h~12h & 16h~19h
- High tariff:
06h~10h & 13h~15h & 20h~21h

Energy Configuration - Gas Price

In the final report, HITACHI solution can be compared with other gas, fuel or biomass boiler applications. To make it possible, all fields of the other solutions must be filled with the detailed information.

The "Restore to default" button select the original values for HI-toolKit software.

Energy Configuration - Fuel Price

In the final report, HITACHI solution can be compared with other gas, fuel or biomass boiler applications. To make it possible, all fields of the other solutions must be filled with the detailed information.

The "Restore to default" button select the original values for HI-toolKit software.

Energy Configuration - Biomass Price

In the final report, HITACHI solution can be compared with other gas, fuel or biomass boiler applications. To make it possible, all fields of the other solutions must be filled with the detailed information.

The "Restore to default" button select the original values for HI-toolKit software.

Energy Configuration - Other

In this screen; the direct electric tank losses can be set.

4

Search settings

In this screen, it is possible to select the following options:

- To display all the units.
- To display only those units which are able to cover up to a determined percentage of load without the use of back-up heater.

2. User preferences

Units of measurements

By Default, HI-toolKit uses the International system of measures to express all the data. However, all the units can be set.

The "Restore to default" button select the original values for HI-toolkit software.

Measure	Default			
Temperature	<input checked="" type="radio"/> °C	<input type="radio"/> °K	<input type="radio"/> °F	
Length + Distance	<input checked="" type="radio"/> mm	<input type="radio"/> m	<input type="radio"/> cm	<input type="radio"/> inch
Surface	<input checked="" type="radio"/> m ²	<input type="radio"/> inch ²		
Weight	<input checked="" type="radio"/> kg	<input type="radio"/> g	<input type="radio"/> lbs	
Volume	<input checked="" type="radio"/> l	<input type="radio"/> gal	<input type="radio"/> m ³	
Flow	<input checked="" type="radio"/> m ³ /h	<input type="radio"/> m ³ /s	<input type="radio"/> liter/min	<input type="radio"/> gal/h <input type="radio"/> gal/s
Pressure	<input checked="" type="radio"/> bar	<input type="radio"/> kPa	<input type="radio"/> atm	
Capacity	<input checked="" type="radio"/> kW	<input type="radio"/> kcal/h	<input type="radio"/> kJ/h	
Energy	<input checked="" type="radio"/> kWh	<input type="radio"/> kJ	<input type="radio"/> kcal	<input type="radio"/> Btu
Gas energy	<input checked="" type="radio"/> kWh	<input type="radio"/> tsm		
CO2 emission	<input checked="" type="radio"/> kg/kwh	<input type="radio"/> lb/kwh		
Currency	<input checked="" type="radio"/> €	<input type="radio"/> £	<input type="radio"/> ¥	<input type="radio"/> CHF

Language selection

By using online web tool, default language of the software is automatically selected by user location; however, it is also possible to use other languages available in the list.

User settings

The user setting will appear allowing the edition of the user preferences.

All data except the Email can be changed.

4

Company customization

A company name and logo can also be used and then it will be shown on the final reports.

Hi-ToolKit
My projects | My preferences
HITACHI

Company customization modified.

My preferences / Company customization

Company information

Company name

Company address

Company postal code

Company city Country

Company logo

UPLOAD THE LOGO OF YOUR COMPANY
Recommended logo size of 200x100 pixels
Max file size of 1MB

Ningún archivo

Installation

User

◆ Start new project

A new project can be performed in only 8 steps, then the final report with the selected unit will be shown. Additionally, the progress of the project is visible in any moment in the menu side.

Project progress

Project data

Installation

Design

DHW Design

Available units

Accessories

Results and plots

Reports

STEP 1	Define information of the new project and customer side.
STEP 2	Define installation criteria's, installation application, type of unit, power supply, etc..)
STEP 3	Define design criteria's: Installation location, heating capacity, water temperature range, etc....
STEP 4	If the DHW option has been activated, the daily pattern of hot water consumption and the DHW tank size can be selected
STEP 5	After installation and design configuration, Hi-toolkit find the range of unit available.
STEP 6	The wide range of heating accessories is displayed and these accessories which best fit in the heating system can be selected
STEP 7	When user select his best the unit, Hi-toolkit produce an extra information by different kind of graphs..
STEP 8	User can print a professional report

If no project is created, click the “New Project” button.

In the “link zone”, accessible clicking in the button “link zone”, there is the available download

STEP 1: Project Data

Complete all the information. This information is used to save the project and to show it in the final report.

- Project name (required field)
- Client name
- Client address
- Client city
- Client postal code
- Comments: Extra comments that could be added.

Once completed, click to “Next – Installation conditions” button.

NOTE
By default, software is using 2016 models only. If older units are needed, uncheck the “Use 2016 models” box.

STEP 2: Installation (1)

In step 2, the installation criteria's (installation application, type of unit, system type, power supply, etc.) must be decided.

HI-tool kit selects those parts into a basic configuration in order to define the best solution, then it shows the proposed hydraulic scheme. An enlarged image of the selected hydraulic circuit will be shown.

- Installation base: By using tick box, the proposed installation can be defined.
 - Heating: The heating of the installation is performed by the heat pump.
 - DHW: Each heat pump system has a water tank, some of which are optional, depending on the solution found. When a water tank is selected, an extra tab appears to fill in the water tank selection.
- Unit Type: There are two type of unit depending on the composition:
 - Monobloc: Units composed by a single outdoor unit, which includes the hydraulic cycle.
 - Split unit are divided in two unit, the internal hydraulic unit and external inverter unit.

(Please note that when Split unit type is selected, the displayed image corresponds always to YUTAKI S system. The purpose is not to show the type of unit, the purpose is to illustrate the difference between monobloc and split systems).

- System Type: System type defines if an auxiliary source to cover the heating demand is selected.
 - Monovalent: The heat pump is sized to cover the 100% of the heating requirements.
 - Mono-Energy: The heat pump is sized to cover the 80% of the heating requirements. An auxiliary electric heater is used to provide the additional heating required on the coldest days of the year.
 - Bivalent: A boiler is configured to alternate with the air to water heat pump on the coldest days of the year.
- Power supply: The power supply defines the available power source at the customer side.
 - Monophasic: One-phase power supply (1~ 230V 50Hz)
 - Three-phase: 3-phases power supply with neutral connection (3N~ 400V 50Hz)
- Space Zone 1: Definition of the installation type of the space heating zone 1.
 - Radiant Floor: Low temperature application.
 - Radiators/Fan coils: Medium/High temperature application.
- Space Zone 2: Definition of the installation type of the space heating zone 2.

Once completed, click to "Next –Design conditions " button.

130

TCGB0098 rev.0 - 04/2016

STEP 2: Installation (2)

If System type selected is Bivalent, one of the following types of boiler shall be selected:

- Gas Boiler
- Oil Fuel Boiler
- Biomass boiler

Remember to set the “Energy configuration” in Installation preferences for the selected boiler.

Once completed, click to “Next – Design conditions” button.

STEP 2: Installation (3)

Each heat pump system has a water tank, some of which are optional, depending on the solution found. When a water tank is selected, an extra tab appears to fill in the water tank selection.

The following types of tank are available to combine with heating systems:

- DHW installation type:
 - Integrated tank
 - External tank
 - Yutempo tank

Once completed, click to “Next –Design conditions” button.

STEP 3: Design (1)

Define design criteria's: Installation location, heating capacity, water temperature range, etc.

- Country and City: When selecting a location, a climate with temperature data for each hour of the year is automatically selected.
- Working period: The heating working period can be selected for different ranges.
- Heating capacity: Required heating capacity to cover all the required load at design temperature.
- Design temperature: Lower outdoor temperature used to design the installation. By default, it is get from the climate data location.
- No load temperature conditions: The heating operation is stopped above this temperature (Min: 12°C, Max: 20°C).
- Maximum water temperature range: Maximum temperature limit of the installation. This value is taken into account for calculation and for the definition of the water rules.
- Minimum water temperature range: Minimum temperature limit of the installation. This value is taken into account for calculation and for the definition of the water rules.

Once completed, click to "Next –Find available units" button.

STEP 3: Design (2)

Example of Working period assignation:

- Heating from: 15th September to 20th December and 10th January to 31 March
- No Heating from: 21th December to 9th January (Christmas Holy-days)

Once completed, click to "Next – Find available units" button.

STEP 3: Design (3)

When the installation conditions selected in "STEP 2: Installation" are Mono-Energy or Bivalent combination, a minimum percentage of the heating capacity covered by the heat pump shall be defined.

Once completed, click to "Next – Find available units" button.

STEP 4: DHW Design

If the DHW option has been activated the daily pattern of hot water consumption and the DHW tank size can be selected.

Hot water consumption on daily pattern:

- Small (Pattern S)
- 2 people (Pattern M)
- Family (Pattern L)
- Big family (Pattern XL)
- Custom

Tanks water volume:

- 200 L
- 260 L

Type of usage	Water temp. at type of usage	Hot water cons. per day	Energy cons. per day	Occurrence per day	Total Energy cons.	Total Volume
Small	40°C	2.11	0.11 kWh	7	0.74 kWh	14.71
Floor	40°C	2.11	0.11 kWh	0	0.0 kWh	0.01
Household cleaning	55°C	2.11	0.11 kWh	1	0.11 kWh	2.11
Small dishwasher	55°C	6.31	0.32 kWh	1	0.32 kWh	6.31
Medium dishwasher	55°C	8.41	0.42 kWh	1	0.42 kWh	8.41
Large dishwasher	55°C	14.72	0.74 kWh	0	0.0 kWh	0.01
Large	40°C	10.52	0.53 kWh	1	0.53 kWh	10.51
Shower	40°C	28.04	1.4 kWh	0	0.0 kWh	0.01
Bath	40°C	7.21	0.36 kWh	0	0.0 kWh	0.01
Total per day at 53°C setting temperature					2.1 kWh	42.11



STEP 5: Available units (1)

After Installation and Design condition have been designed, HI-toolkit start to search the most suitable units.

Note: The process could take 10 to 20 seconds depending on the selected conditions.

STEP 5: Available units (2)

The Hi-toolkit software selects the best YUTAKI systems using an inner simulation to get solutions which cover all installation and design conditions by using a weather database during a year, after that, the Hi-toolkit software shows a wide variety of data:

- Total thermal energy (Capacity)
- Input power (IPT)
- Total energy consumption (by Heat pump and booster heater if available)
- Seasonal coefficient of performance (SCOP)
- Etc.

Once the unit has been selected, click to "Next - Detailed calculations and plots" button.

The screenshot shows the '5. Available units' screen in the Hi-ToolKit software. It features a line graph with 'Capacity' on the y-axis (0 kW to 25 kW) and 'Temperature' on the x-axis (-8 °C to 20 °C). Three lines are plotted: 'Load capacity (kW)' (blue, decreasing), 'Unit maximum capacity (kW)' (yellow, increasing), and 'Heater operation area (kW)' (grey, increasing). Below the graph, 'Design Conditions' are listed: Heating capacity: 12.5 kW, Design Temperature: -7.0 °C, Maximum water temp range: 35.0 °C. 'DRWT Design Conditions' include: DRWT duty pattern: Smart (Pattern 3), Cold water inlet temperature: 12 °C, DRWT construction type: Stainless, Annual heating capacity (estimated): 29055.6 kWh, No load temperature: 20.0 °C, Minimum water temp range: 20.0 °C, Hot water target temperature: 53 °C, and DRWT installation type: Integrated tank. A table at the bottom lists two unit options:

Indoor	Outdoor	Family	HP / PDesign	BP	WPE	SCOP	A. Coverage	Cost
RSD4-DWHE-2005	RAS-GSHNPE	SC	107%	-	5443.15 kWh	5.40	100%	648.37 €
RSD4-DWHE-2005	RAS-GSHNPE	SC	100%	+	5471.36 kWh	5.40	100%	652.29 €

Buttons for 'Next - Accessories >' and '< Back' are visible at the bottom.

STEP 6: Accessories selection

Hi-ToolKit

[About](#) | [Privacy conditions](#) | [Terms of use](#)









Welcome HITACHI | [Logout](#)

[my projects](#) | [my preferences](#)



HITACHI

6. Accessories selection









Control accessories

Image	Reference	Description	Selection
	PC-ARPHE	Wired Room Thermostat (ENES/DEFRIT/3V)	<input type="text" value="0"/>
	PC-ARPHE-01	Wired Room Thermostat (ENPT/DANJ/EL)	<input type="text" value="0"/>
	ATW-RTU-04	Wireless ON/OFF Thermostat	<input type="text" value="0"/>
	ATW-RTU-05	Wireless Intelligent Thermostat	<input type="text" value="0"/>
	ATW-RTU-06	Wireless Intelligent Thermostat C2	<input type="text" value="0"/>
	ATW-MBS-02	Modbus Serie 2	<input type="text" value="0"/>
	ATW-KNX-02	KNX Serie 2	<input type="text" value="0"/>
	ATW-TAG-02	Tahoma Gateway Serie 2	<input type="text" value="0"/>

Temperature sensor accessories

Image	Reference	Description	Selection
	ATW-WTS-02Y	Water Temperature Sensor	<input type="text" value="0"/>
	ATW-ITS-01	Indoor temperature sensor	<input type="text" value="0"/>

Water circuit accessories

Image	Reference	Description	Selection
	ATW-HSK-01 (BDHM1)	Hydraulic Separator	<input type="text" value="0"/>
	ATW-3WV-01 (VDSV1)	3-Way Valve	<input type="text" value="0"/>
	ATW-AQT-01 (ASMBH1)	Aquastat	<input type="text" value="0"/>
	ATW-OPOV-01	Differential Pressure Overflow Valve	<input type="text" value="0"/>
	ATW-WEH-06	Water Electrical Heater	<input type="text" value="0"/>
	ATW-CKSC-01	Cooling Kit for SC 2-6HP	<input type="text" value="0"/>
	To be informed later ATW-MAK-01	4.20MA kit	<input type="text" value="0"/>
	ATW-FWP-02	Flex water pipe	<input type="text" value="0"/>
	ATW-AOS-02	Auxiliary Outputs signals	<input type="text" value="0"/>

Project progress

- Project data
- Installation
- Design
- DHW Design
- Available units
- Accessories
- Results and plots
- Report

Next - Download calculations and plots >
← Back

In this screen, the heating accessories which best fit in your system can be selected between 3 main groups:

- Control accessories
- Temperature sensor accessories
- Water circuit accessories

STEP 7: Results and plots

When the best unit has been selected, the Hi-toolkit software produces extra information through different kind of graphs and explanations:

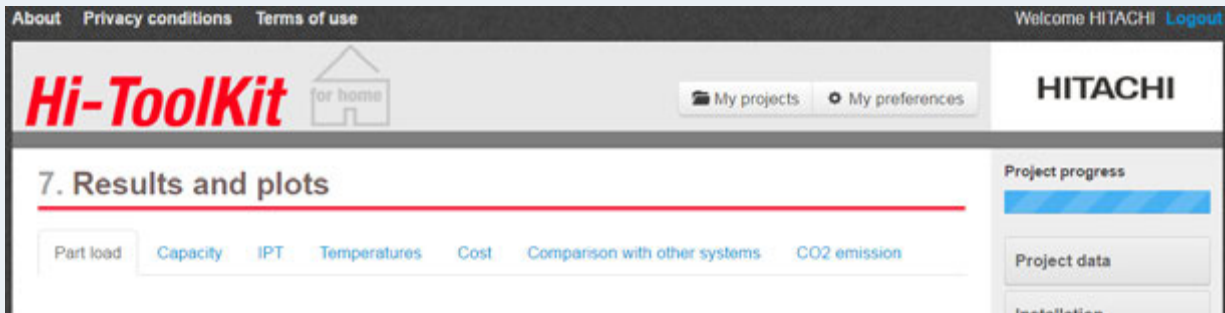

Part load unit regulation (kWh): Heating demand and heating capacity of the unit (in regulation and maximum).

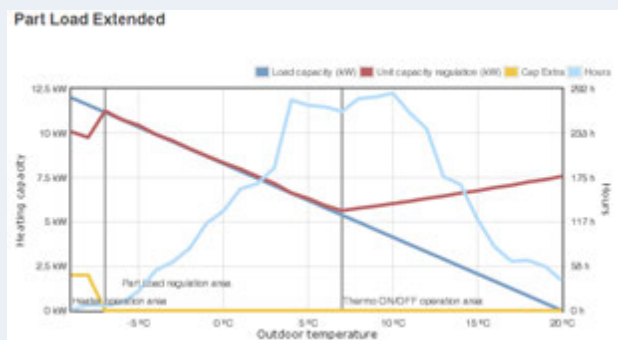
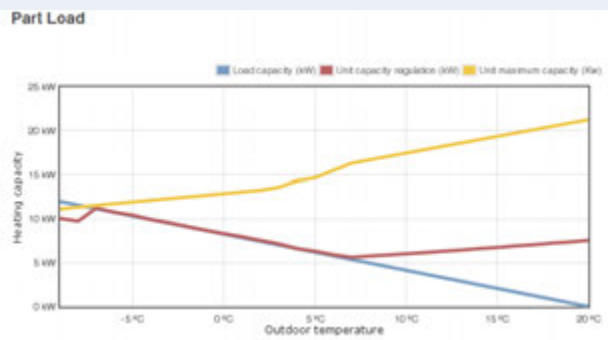

Total Thermal Energy (kWh): Heating total thermal energy of the installation per month.

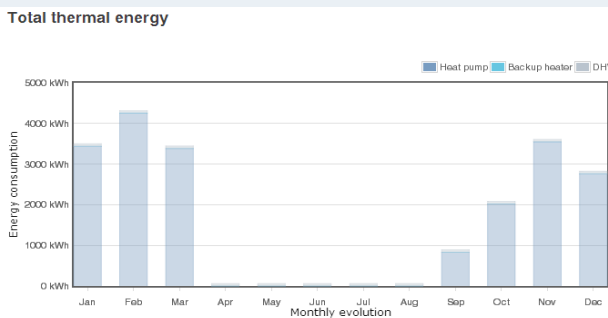

Heating Unit Maximum Capacity (kWh): Heating demand and maximum heating capacity of the unit.

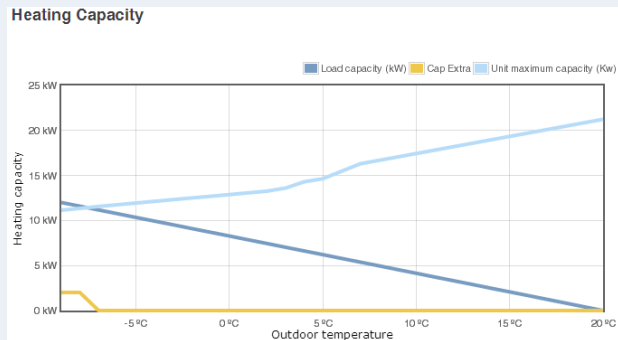

Annual Power consumption (kWh): Annual power electric consumption per month.

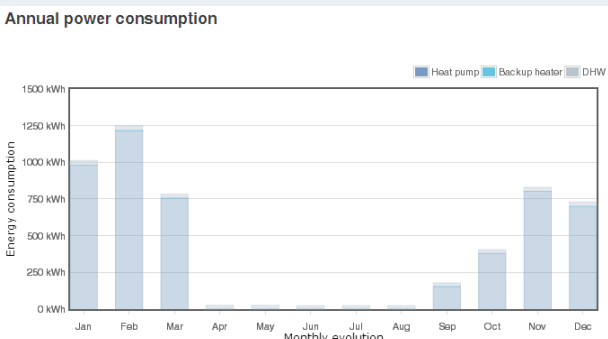

Average outdoor ambient temperature (°C): Ambient average temperature into the selected location.

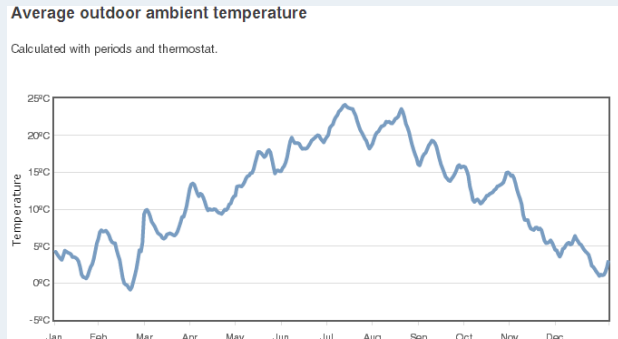

STEP 7: Results and plots

Hourly temperature distribution per year (hours): Number of hours per temperature during the year in the selected location.

Hourly temperature distribution per year

Calculated with periods and thermostat.

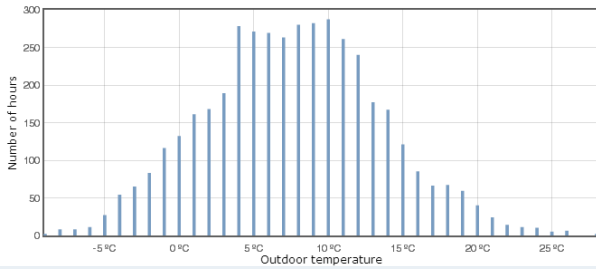

Monthly Energy Cost (€): Total energy cost per month of the YUTAKI unit of the heating installation.

Monthly Energy Cost

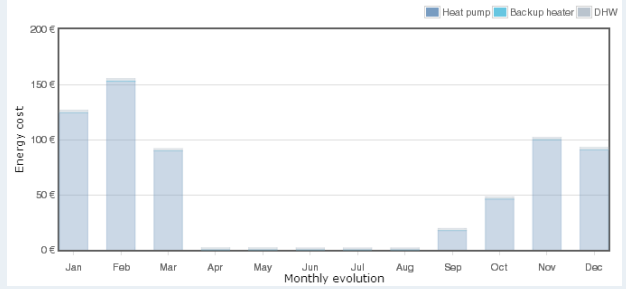

Annual energy cost comparison (€): Simulated annual cost of YUTAKI unit in comparison with Fuel, Gas, Biomass and direct electricity units.

Heating energy cost

Annual cost and comparison with others systems

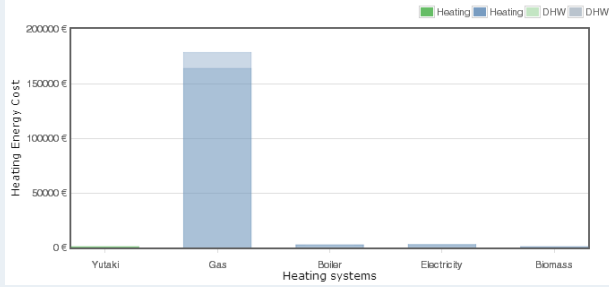

Heating CO2 emission (Ton/year): The CO2 emission of the different energy sources is displayed.

Heating CO2 emission

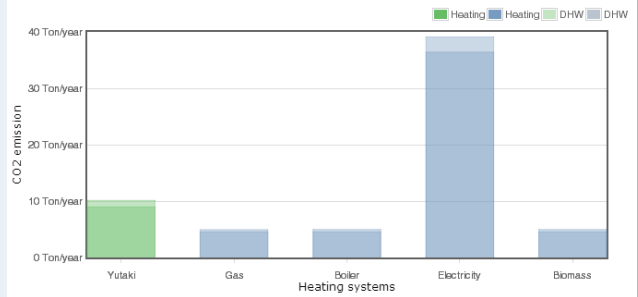

STEP 8: Report (1)

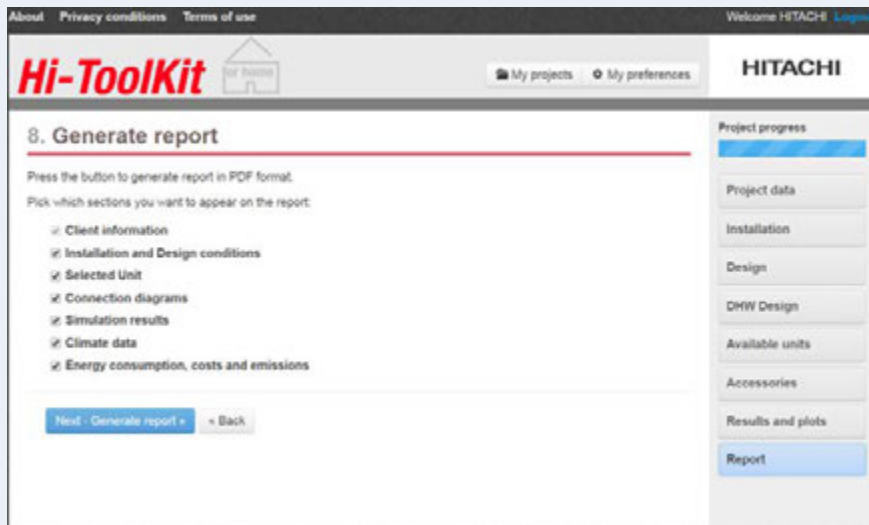

Finally, the information which will be shown in the final report can be decided between the following list:

- Client information: All the information from the customer (It always is shown).
- Installation and design conditions: All the information from installation and design conditions selected.
- Selected units: Technical information of YUTAKI system selected and material list needed for the installation.
- Connections diagrams: Hydraulic and electrical connection schemes.
- Simulation results: All the information of capacity, input, graphics, etc.
- Climate data: All information of climate database for the location selected.
- Energy consumption, cost and emissions: All the information of capacity, input, graphics, etc.
- Field settings: All settings on the YUTAKI system, which needs to be performed in the commissioning by selection criteria.

STEP 8: Report (2)

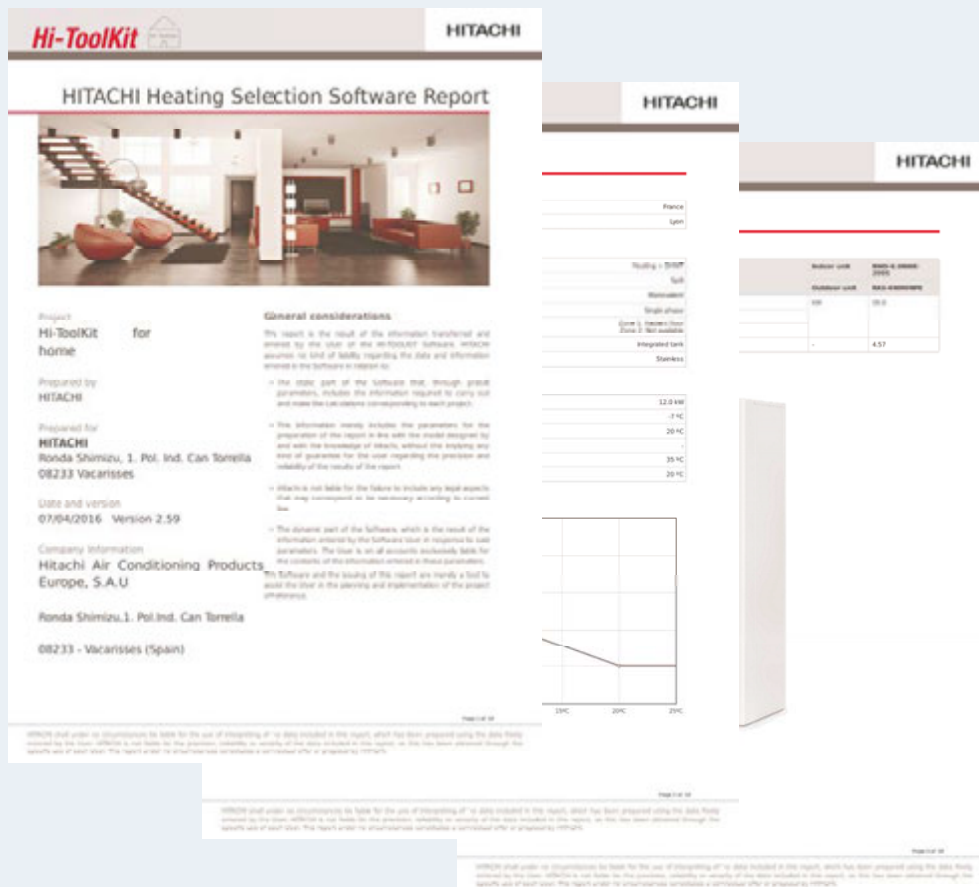

4.3 YUTAKI S

4.3.1 Maximum heating capacity table (kW) (Integrated)

System	Water outlet temp (°C)	Ambient temperature (°C WB)																			
		-20		-15		-10		-7		-2		2		7		12		15		20	
		CAP (kW)	IPT (kW)	CAP (kW)	IPT (kW)	CAP (kW)	IPT (kW)	CAP (kW)	IPT (kW)	CAP (kW)	IPT (kW)	CAP (kW)	IPT (kW)	CAP (kW)	IPT (kW)	CAP (kW)	IPT (kW)	CAP (kW)	IPT (kW)	CAP (kW)	IPT (kW)
RAS-2WHVNP + RWM-2.0NE	60	-	-	-	-	-	-	-	-	-	-	-	-	-	-	-	-	-	-	-	-
	55	-	-	-	-	3.80	2.24	4.20	2.27	4.30	1.98	4.60	1.84	6.00	2.22	6.90	2.16	7.50	1.98	8.50	1.69
	50	-	-	-	-	4.02	2.08	4.41	2.10	4.45	1.88	4.70	1.78	6.10	2.65	7.05	1.94	7.65	1.84	8.70	1.68
	45	-	-	4.00	2.22	4.38	2.08	4.60	1.99	4.70	1.81	4.80	1.71	6.20	1.82	7.10	1.69	7.70	1.68	8.90	1.71
	40	-	-	4.25	2.09	4.51	1.95	4.66	1.87	4.93	1.73	5.15	1.62	6.60	1.69	7.55	1.52	8.16	1.50	9.20	1.46
	35	-	-	4.50	1.96	4.64	1.82	4.70	1.73	5.16	1.62	5.50	1.53	7.00	1.56	8.00	1.36	8.40	1.28	9.70	1.26
	30	-	-	4.70	1.96	5.20	1.92	5.50	1.90	5.77	1.68	5.99	1.51	7.30	1.55	8.10	1.33	8.70	1.31	9.90	1.31
	25	-	-	5.20	1.96	5.64	1.85	5.90	1.79	6.06	1.63	6.19	1.50	7.70	1.54	8.50	1.37	9.10	1.36	10.00	1.33
	20	-	-	5.70	1.97	6.08	1.79	6.30	1.68	6.35	1.57	6.40	1.48	8.10	1.53	8.90	1.41	9.38	1.40	10.18	1.37
RAS-2.5WHVNP + RWM-2.5NE	60	-	-	-	-	-	-	-	-	-	-	-	-	-	-	-	-	-	-	-	-
	55	-	-	-	-	4.00	2.35	5.00	2.87	5.30	2.56	5.50	2.29	8.00	2.97	8.90	2.87	9.44	2.86	10.10	2.77
	50	-	-	-	-	4.40	2.32	5.10	2.62	6.05	2.73	6.59	2.66	8.50	3.05	9.10	2.69	9.91	2.78	10.20	2.62
	45	-	-	4.40	2.38	5.08	2.49	5.50	2.55	5.94	2.41	6.30	2.29	8.90	2.97	9.30	2.27	9.80	2.22	10.40	2.06
	40	-	-	4.55	2.31	5.18	2.36	5.57	2.40	6.17	2.27	6.65	2.17	9.00	2.50	9.50	2.12	10.20	2.13	10.60	1.98
	35	-	-	4.70	2.24	5.29	2.24	5.70	2.27	6.40	2.14	7.00	2.06	9.00	2.00	10.00	2.04	10.60	2.05	10.90	1.93
	30	-	-	4.90	2.09	5.65	2.14	6.10	2.18	6.52	1.95	6.86	1.77	9.50	2.11	10.20	1.73	10.70	1.68	11.00	1.53
	25	-	-	5.50	2.17	6.29	2.15	6.77	2.14	7.11	2.01	7.39	1.91	10.00	1.89	10.50	1.81	10.80	1.80	11.20	1.76
	20	-	-	6.10	2.09	6.94	2.14	7.44	2.18	7.70	1.86	7.91	1.77	10.50	2.11	10.80	1.73	11.00	1.67	11.50	1.61
RAS-3WHVNP + RWM-3.0NE	60	-	-	-	-	-	-	-	-	-	-	-	-	-	-	-	-	-	-	-	-
	55	-	-	-	-	4.50	3.21	5.50	3.55	6.33	3.46	7.00	3.40	9.20	3.83	10.50	3.68	11.00	3.57	11.40	3.28
	50	-	-	-	-	5.46	3.45	6.05	3.58	6.82	3.48	7.44	3.40	9.86	3.61	10.70	3.49	11.20	3.49	11.62	3.37
	45	-	-	5.50	3.33	5.70	2.93	6.40	3.04	7.14	3.01	7.70	2.96	10.00	3.22	11.00	2.89	11.50	2.82	11.70	2.56
	40	-	-	5.62	3.10	6.00	2.82	6.58	2.93	7.53	2.91	8.30	2.89	10.49	2.95	11.50	2.70	11.80	2.59	11.90	2.36
	35	-	-	5.90	2.95	6.40	2.85	6.71	2.80	7.92	2.81	8.90	2.83	11.00	2.68	11.70	2.44	11.90	2.34	12.10	2.16
	30	-	-	6.10	2.84	6.66	2.68	7.00	2.59	8.10	2.61	9.40	2.76	11.10	2.52	12.00	2.11	12.10	1.95	12.30	1.74
	25	-	-	6.50	2.61	6.90	2.43	7.10	2.31	8.30	2.40	10.20	2.71	11.30	2.22	12.10	2.16	12.30	2.11	12.40	2.00
	20	-	-	7.00	2.42	7.10	2.17	7.20	2.03	8.50	2.15	10.30	2.41	11.50	1.91	12.20	2.22	12.40	2.27	12.60	2.32
RAS-4WH(V)NPE + RWM-4.0NE	60	-	-	-	-	6.50	4.33	6.80	4.12	6.91	3.60	7.00	3.18	8.50	3.40	10.20	3.64	11.22	3.79	13.00	4.06
	55	-	-	-	-	7.20	4.30	9.70	5.56	9.90	4.86	10.50	4.47	13.50	4.75	14.36	5.16	14.77	5.37	15.46	3.50
	50	-	-	-	-	7.79	3.95	9.87	4.50	10.00	4.16	10.90	4.19	13.88	4.33	14.83	4.45	15.39	4.51	16.34	4.63
	45	7.20	4.03	8.28	4.05	9.35	4.07	10.00	4.08	10.60	3.95	11.50	3.97	14.10	3.85	15.30	3.73	16.02	3.66	17.00	3.49
	40	8.10	4.16	8.95	4.12	9.80	4.07	10.31	4.05	11.00	3.93	11.80	3.92	14.65	3.56	15.65	3.40	16.25	3.31	17.25	3.15
	35	9.00	4.29	9.62	4.18	10.25	4.08	10.62	4.01	11.83	4.08	12.80	4.13	15.20	3.27	16.00	3.08	16.48	2.96	17.50	2.81
	30	10.00	4.34	10.77	4.22	11.53	4.10	11.99	4.03	12.72	3.90	13.30	3.80	15.90	3.31	16.60	2.81	17.02	2.51	17.72	2.60
	25	11.64	4.44	12.16	4.31	12.68	4.18	13.00	4.10	13.72	3.98	13.58	3.61	16.10	2.82	17.00	2.74	17.54	2.69	18.44	2.55
	20	13.28	4.55	13.56	4.40	13.84	4.26	14.00	4.18	14.72	4.06	13.78	3.46	16.30	2.34	17.40	2.67	18.06	2.87	19.16	2.50
RAS-5WH(V)NPE + RWM-5.0NE	60	-	-	-	-	7.47	5.45	8.19	5.97	8.16	5.27	8.14	4.72	11.20	5.62	11.40	5.33	12.00	5.43	14.00	6.08
	55	-	-	-	-	9.22	6.36	11.20	6.22	12.21	6.24	12.96	6.22	15.20	6.30	16.00	5.71	16.50	5.37	16.70	3.86
	50	-	-	-	-	9.99	5.81	11.42	5.87	12.45	5.64	13.27	5.45	15.46	5.41	16.50	4.93	16.80	4.55	17.10	3.92
	45	8.10	4.54	9.43	4.90	10.76	5.27	11.60	5.50	12.68	5.04	13.59	4.69	15.70	4.53	17.00	4.15	17.50	3.86	18.00	3.51
	40	8.90	4.61	10.02	4.81	11.15	5.00	11.82	5.12	12.89	4.75	13.75	4.45	16.13	4.10	17.15	3.77	17.70	3.56	18.50	3.19
	35	9.70	4.69	10.62	4.71	11.53	4.74	12.00	4.72	13.10	4.46	13.90	4.21	16.70	3.70	17.30	3.39	17.80	3.24	18.80	3.55
	30	10.70	4.74	11.28	4.55	11.85	4.35	12.20	4.24	13.26	4.18	14.10	4.14	17.20	3.58	17.90	3.03	17.96	2.63	19.10	3.38
	25	11.16	4.42	12.25	4.42	13.34	4.42	14.00	4.42	14.70	4.32	15.27	4.24	17.90	3.51	18.50	3.08	18.80	2.82	19.50	3.13
	20	11.61	4.10	13.22	4.30	14.83	4.49	15.80	4.60	16.15	4.46	16.43	4.34	18.10	3.33	18.80	3.08	19.00	2.90	20.00	2.71



System	Water outlet temp (°C)	Ambient temperature (°C WB)																			
		-20		-15		-10		-7		-2		2		7		12		15		20	
		CAP (kW)	IPT (kW)	CAP (kW)	IPT (kW)	CAP (kW)	IPT (kW)	CAP (kW)	IPT (kW)	CAP (kW)	IPT (kW)	CAP (kW)	IPT (kW)	CAP (kW)	IPT (kW)	CAP (kW)	IPT (kW)	CAP (kW)	IPT (kW)	CAP (kW)	IPT (kW)
RAS-6WH(V)NPE + RWM-6.0NE	60	-	-	-	-	7.80	5.57	8.30	5.72	9.02	5.35	9.60	5.05	12.00	5.71	12.10	5.50	13.00	5.75	15.00	6.37
	55	-	-	-	-	10.38	7.39	12.00	7.18	12.96	7.09	13.96	7.16	17.00	7.13	17.20	6.14	17.30	5.56	17.40	4.60
	50	-	-	-	-	10.77	6.39	11.83	6.32	12.98	6.19	13.90	6.09	17.10	6.19	17.30	5.92	17.50	5.77	18.00	5.56
	45	9.00	4.86	10.32	5.34	11.63	5.81	12.50	6.13	13.56	5.68	14.48	5.36	17.30	5.33	17.50	4.49	18.00	4.14	18.60	3.51
	40	9.55	5.12	10.75	5.33	11.95	5.54	12.67	5.66	13.81	5.31	14.73	5.02	17.55	4.69	18.10	4.12	18.30	3.76	19.00	3.24
	35	10.10	5.37	11.18	5.32	12.27	5.26	13.00	5.27	14.06	4.93	15.00	4.69	17.80	4.05	18.20	3.64	18.60	3.54	19.60	3.43
	30	10.71	4.56	12.57	4.84	13.99	4.93	14.83	4.99	15.12	4.72	15.35	4.51	18.10	3.77	18.60	3.15	19.10	3.14	20.00	3.13
	25	11.30	4.48	12.83	4.63	14.02	4.64	14.73	4.65	15.18	4.47	15.54	4.33	18.50	3.78	19.90	3.37	20.50	3.27	21.00	3.05
	20	12.13	4.48	13.09	4.42	14.05	4.36	14.63	4.32	15.24	4.22	15.72	4.15	18.90	3.78	20.90	3.54	21.10	3.31	22.00	3.04
RAS-8WHNPE + RWM-8.0NE	60	-	-	-	-	11.92	9.47	13.14	9.00	14.98	9.45	16.45	9.81	21.15	12.41	22.00	10.61	22.50	8.56	23.50	5.60
	55	-	-	-	-	12.79	8.88	14.50	9.67	15.30	8.15	15.95	6.93	24.00	9.60	24.50	9.07	24.80	8.37	25.10	7.13
	50	-	-	-	-	13.65	8.28	15.70	9.58	16.75	8.97	17.58	8.48	24.01	10.45	24.90	9.31	25.50	7.83	26.10	5.59
	45	10.28	7.73	12.71	8.12	15.14	8.51	16.60	8.74	17.66	7.69	18.50	6.85	25.00	7.94	26.00	7.65	26.50	6.97	26.90	5.85
	40	12.20	8.54	13.31	7.82	15.77	8.04	17.24	8.17	18.36	7.39	19.25	6.76	25.25	7.41	26.30	6.98	26.90	6.76	27.10	6.25
	35	14.00	9.15	14.50	7.84	16.39	7.57	17.90	7.61	19.06	7.08	20.00	6.67	25.50	6.89	26.50	6.31	27.10	6.00	27.90	5.53
	30	14.80	8.60	14.27	7.12	16.97	7.51	18.58	7.74	19.38	6.80	20.02	6.04	26.50	6.97	27.00	6.28	27.60	6.02	28.10	5.53
	25	15.90	7.81	16.20	7.19	17.22	7.12	19.11	7.66	19.96	6.78	20.64	6.07	27.10	6.95	27.50	6.11	28.00	5.78	28.50	5.23
	20	16.00	6.22	16.50	6.38	17.47	6.74	19.64	7.57	20.55	6.76	21.27	6.11	27.70	6.92	28.00	5.95	28.50	5.57	29.00	4.97
RAS-10WHNPE + RWM-10.0NE	60	-	-	-	-	13.90	10.69	14.50	8.06	16.17	8.44	17.50	8.75	22.00	9.57	23.50	11.19	24.30	9.17	25.00	5.79
	55	-	-	-	-	15.76	13.87	17.30	12.36	18.61	10.71	19.50	9.29	25.52	10.65	26.00	10.83	26.50	9.58	27.20	7.42
	50	-	-	-	-	16.37	12.80	18.36	12.84	18.97	10.35	19.46	8.35	28.05	10.64	28.60	10.51	29.00	9.41	29.90	7.63
	45	13.00	8.67	14.81	9.52	17.12	10.71	18.50	11.42	19.89	9.24	21.00	7.50	32.00	10.67	33.00	10.64	33.20	9.78	33.60	8.40
	40	14.20	9.17	15.44	9.10	18.13	9.96	19.74	10.48	20.36	9.04	20.85	7.89	32.00	9.54	33.50	9.47	33.50	9.18	33.80	8.80
	35	15.10	9.44	16.07	8.67	18.50	8.90	21.00	9.55	21.00	8.91	21.70	8.68	32.00	8.42	34.00	8.29	34.70	8.25	34.90	7.97
	30	15.70	8.72	16.01	7.60	18.70	7.91	21.63	8.66	22.95	8.79	24.00	8.89	33.20	8.85	34.30	7.98	35.00	7.99	35.10	7.78
	25	16.40	8.63	16.35	7.41	18.80	7.63	22.03	8.48	23.74	8.90	25.11	9.24	33.50	8.70	34.50	6.90	35.80	7.02	36.20	6.88
	20	17.00	8.47	17.50	7.56	19.00	7.39	22.43	8.30	24.54	9.02	26.00	9.52	33.00	8.35	35.00	6.00	36.10	6.10	37.00	6.14



NOTE

- CAP: Capacity at compressor maximum frequency. Capacity is valid for difference between water inlet and water outlet of 3-8°C.
- IPT: Total input power.

The table above shows the input power (IPT) at maximum capacity (CAP). Most of the time, the unit will run at partial load, so that the actual input power will be lower.

4.3.2 Maximum cooling capacity table (kW)

System	Water outlet temperature (°C)	Ambient temperature (°C DB)							
		10	15	20	25	30	35	40	45
		CAP (kW)	CAP (kW)	CAP (kW)	CAP (kW)	CAP (kW)	CAP (kW)	CAP (kW)	CAP (kW)
RWM-2.0FSN3E + RAS-2WHVNP	20	-	-	-	6.7	6.4	6.0	5.7	5.4
	18	-	-	7.1	6.6	6.3	6.1	5.6	5.0
	15	6.1	6.2	6.2	6.3	5.9	5.5	5.2	4.8
	10	5.8	5.7	5.7	5.7	5.4	5.1	4.8	4.6
	7	5.5	5.6	5.4	5.3	5.1	4.9	4.7	4.4
RAS-2.5WHVNP + RWM-2.5NE	20	-	-	-	7.6	7.2	6.9	6.5	6.1
	18	-	-	8.5	8.0	7.8	7.4	6.6	5.7
	15	8.4	8.1	7.8	7.6	7.1	6.6	6.1	5.6
	10	7.5	7.3	7.0	6.8	6.5	6.1	5.8	5.4
	7	7.0	6.8	6.5	6.4	6.1	5.8	5.6	5.3
RAS-3WHVNP + RWM-3.0NE	20	-	-	-	8.9	8.4	8.0	7.5	7.0
	18	-	-	9.0	8.9	8.7	8.5	7.5	6.5
	15	8.9	8.8	8.6	8.5	7.9	7.4	6.9	6.4
	10	8.6	8.3	8.0	7.8	7.4	6.9	6.5	6.1
	7	8.2	8.1	7.8	7.3	7.2	7.0	6.5	6.0
RAS-4WH(V)NPE + RWM-4.0NE	20	-	-	-	16.1	15.7	15.2	14.8	14.3
	18	-	-	17.0	16.1	15.1	15.0	14.4	13.7
	15	16.0	15.8	15.5	15.3	14.6	14.0	13.3	12.7
	10	15.1	14.7	14.4	14.0	13.2	12.5	11.7	11.0
	7	14.0	13.9	13.4	13.2	12.3	11.8	10.9	9.9
RAS-5WH(V)NPE + RWM-5.0NE	20	-	-	-	18.3	18.0	17.7	17.3	17.0
	18	-	-	18.5	17.6	17.4	16.0	15.0	14.0
	15	17.1	17.1	17.0	17.1	16.1	15.1	14.1	13.0
	10	16.6	16.5	16.4	16.2	15.0	13.8	12.6	11.4
	7	16.1	15.9	15.4	15.7	13.2	12.6	11.5	10.4
RAS-6WH(V)NPE + RWM-6.0NE	20	-	-	-	20.0	19.6	19.3	18.9	18.5
	18	-	-	20.0	19.0	17.8	17.5	17.3	16.8
	15	18.0	18.1	18.2	18.3	17.5	16.8	16.0	15.2
	10	17.5	17.4	17.2	17.1	16.0	14.9	13.7	12.6
	7	17.0	16.8	16.3	16.4	14.9	13.7	12.4	11.0
RAS-8WHNPE + RWM-8.0NE	20	-	-	-	25.8	25.0	24.2	23.4	22.6
	18	-	-	25.1	24.6	24.0	23.5	22.3	21.0
	15	23.2	23.0	22.8	22.6	21.8	21.1	20.4	19.6
	10	21.1	20.4	19.8	19.2	18.7	18.3	17.8	17.4
	7	24.0	19.9	19.2	17.2	16.7	16.4	16.2	16.0
RAS-10WHNPE + RWM-10.0NE	20	-	-	-	28.6	27.7	26.8	25.9	25.0
	18	-	-	28.5	28.0	27.5	27.0	25.0	23.0
	15	26.0	26.1	26.1	26.2	25.1	23.9	22.8	21.6
	10	25.3	24.6	23.9	23.2	22.2	21.3	20.3	19.4
	7	24.0	23.6	22.8	21.4	21.0	20.6	19.3	18.0

**NOTE**

CAP: Capacity at compressor maximum frequency. Capacity is valid for difference between water inlet and water outlet of 3-8°C.

4.4 YUTAKI S COMBI

4.4.1 Maximum heating capacity table (kW) (Integrated)

System	Water outlet temp (°C)	Ambient temperature (°C WB)																			
		-20		-15		-10		-7		-2		2		7		12		15		20	
		CAP (kW)	IPT (kW)	CAP (kW)	IPT (kW)	CAP (kW)	IPT (kW)	CAP (kW)	IPT (kW)	CAP (kW)	IPT (kW)	CAP (kW)	IPT (kW)	CAP (kW)	IPT (kW)	CAP (kW)	IPT (kW)	CAP (kW)	IPT (kW)	CAP (kW)	IPT (kW)
RAS-2WHVNP + RWD-2.0NW(S) E-(200/260)S(-K)	60	-	-	-	-	-	-	-	-	-	-	-	-	-	-	-	-	-	-	-	-
	55	-	-	-	-	3.80	2.24	4.20	2.27	4.30	1.98	4.60	1.84	6.00	2.22	6.90	2.16	7.50	1.98	8.50	1.69
	50	-	-	-	-	4.02	2.08	4.41	2.10	4.45	1.88	4.70	1.78	6.10	2.65	7.05	1.94	7.65	1.84	8.70	1.68
	45	-	-	4.00	2.22	4.38	2.08	4.60	1.99	4.70	1.81	4.80	1.71	6.20	1.82	7.10	1.69	7.70	1.68	8.90	1.71
	40	-	-	4.25	2.09	4.51	1.95	4.66	1.87	4.93	1.73	5.15	1.62	6.60	1.69	7.55	1.52	8.16	1.50	9.20	1.46
	35	-	-	4.50	1.96	4.64	1.82	4.70	1.73	5.16	1.62	5.50	1.53	7.00	1.56	8.00	1.36	8.40	1.28	9.70	1.26
	30	-	-	4.70	1.96	5.20	1.92	5.50	1.90	5.77	1.68	5.99	1.51	7.30	1.55	8.10	1.33	8.70	1.31	9.90	1.31
	25	-	-	5.20	1.96	5.64	1.85	5.90	1.79	6.06	1.63	6.19	1.50	7.70	1.54	8.50	1.37	9.10	1.36	10.00	1.33
	20	-	-	5.70	1.97	6.08	1.79	6.30	1.68	6.35	1.57	6.40	1.48	8.10	1.53	8.90	1.41	9.38	1.40	10.18	1.37
RAS-2.5WHVNP + RWD-2.5NW(S) E-(200/260)S(-K)	60	-	-	-	-	-	-	-	-	-	-	-	-	-	-	-	-	-	-	-	-
	55	-	-	-	-	4.00	2.35	5.00	2.87	5.30	2.56	5.50	2.29	8.00	2.97	8.90	2.87	9.44	2.86	10.10	2.77
	50	-	-	-	-	4.40	2.32	5.10	2.62	6.05	2.73	6.59	2.66	8.50	3.05	9.10	2.69	9.91	2.78	10.20	2.62
	45	-	-	4.40	2.38	5.08	2.49	5.50	2.55	5.94	2.41	6.30	2.29	8.90	2.97	9.30	2.27	9.80	2.22	10.40	2.06
	40	-	-	4.55	2.31	5.18	2.36	5.57	2.40	6.17	2.27	6.65	2.17	9.00	2.50	9.50	2.12	10.20	2.13	10.60	1.98
	35	-	-	4.70	2.24	5.29	2.24	5.70	2.27	6.40	2.14	7.00	2.06	9.00	2.00	10.00	2.04	10.60	2.05	10.90	1.93
	30	-	-	4.90	2.09	5.65	2.14	6.10	2.18	6.52	1.95	6.86	1.77	9.50	2.11	10.20	1.73	10.70	1.68	11.00	1.53
	25	-	-	5.50	2.17	6.29	2.15	6.77	2.14	7.11	2.01	7.39	1.91	10.00	1.89	10.50	1.81	10.80	1.80	11.20	1.76
	20	-	-	6.10	2.09	6.94	2.14	7.44	2.18	7.70	1.86	7.91	1.77	10.50	2.11	10.80	1.73	11.00	1.67	11.50	1.61
RAS-3WHVNP + RWD-2.0NW(S) E-(200/260)S(-K)	60	-	-	-	-	-	-	-	-	-	-	-	-	-	-	-	-	-	-	-	-
	55	-	-	-	-	4.50	3.21	5.50	3.55	6.33	3.46	7.00	3.40	9.20	3.83	10.50	3.68	11.00	3.57	11.40	3.28
	50	-	-	-	-	5.46	3.45	6.05	3.58	6.82	3.48	7.44	3.40	9.86	3.61	10.70	3.49	11.20	3.49	11.62	3.37
	45	-	-	5.50	3.33	5.70	2.93	6.40	3.04	7.14	3.01	7.70	2.96	10.00	3.22	11.00	2.89	11.50	2.82	11.70	2.56
	40	-	-	5.62	3.10	6.00	2.82	6.58	2.93	7.53	2.91	8.30	2.89	10.49	2.95	11.50	2.70	11.80	2.59	11.90	2.36
	35	-	-	5.90	2.95	6.40	2.85	6.71	2.80	7.92	2.81	8.90	2.83	11.00	2.68	11.70	2.44	11.90	2.34	12.10	2.16
	30	-	-	6.10	2.84	6.66	2.68	7.00	2.59	8.10	2.61	9.40	2.76	11.10	2.52	12.00	2.11	12.10	1.95	12.30	1.74
	25	-	-	6.50	2.61	6.90	2.43	7.10	2.31	8.30	2.40	10.20	2.71	11.30	2.22	12.10	2.16	12.30	2.11	12.40	2.00
	20	-	-	7.00	2.42	7.10	2.17	7.20	2.03	8.50	2.15	10.30	2.41	11.50	1.91	12.20	2.22	12.40	2.27	12.60	2.32
RAS-4WH(V)NPE + RWD-2.0NW(S) E-(200/260)S(-K)	60	-	-	-	-	6.50	4.33	6.80	4.12	6.91	3.60	7.00	3.18	8.50	3.40	10.20	3.64	11.22	3.79	13.00	4.06
	55	-	-	-	-	7.20	4.30	9.70	5.56	9.90	4.86	10.50	4.47	13.50	4.75	14.36	5.16	14.77	5.37	15.46	3.50
	50	-	-	-	-	7.79	3.95	9.87	4.50	10.00	4.16	10.90	4.19	13.88	4.33	14.83	4.45	15.39	4.51	16.34	4.63
	45	7.20	4.03	8.28	4.05	9.35	4.07	10.00	4.08	10.60	3.95	11.50	3.97	14.10	3.85	15.30	3.73	16.02	3.66	17.00	3.49
	40	8.10	4.16	8.95	4.12	9.80	4.07	10.31	4.05	11.00	3.93	11.80	3.92	14.65	3.56	15.65	3.40	16.25	3.31	17.25	3.15
	35	9.00	4.29	9.62	4.18	10.25	4.08	10.62	4.01	11.83	4.08	12.80	4.13	15.20	3.27	16.00	3.08	16.48	2.96	17.50	2.81
	30	10.00	4.34	10.77	4.22	11.53	4.10	11.99	4.03	12.72	3.90	13.30	3.80	15.90	3.31	16.60	2.81	17.02	2.51	17.72	2.60
	25	11.64	4.44	12.16	4.31	12.68	4.18	13.00	4.10	13.72	3.98	13.58	3.61	16.10	2.82	17.00	2.74	17.54	2.69	18.44	2.55
	20	13.28	4.55	13.56	4.40	13.84	4.26	14.00	4.18	14.72	4.06	13.78	3.46	16.30	2.34	17.40	2.67	18.06	2.87	19.16	2.50

System	Water outlet temp (°C)	Ambient temperature (°C WB)																			
		-20		-15		-10		-7		-2		2		7		12		15		20	
		CAP (kW)	IPT (kW)	CAP (kW)	IPT (kW)	CAP (kW)	IPT (kW)	CAP (kW)	IPT (kW)	CAP (kW)	IPT (kW)	CAP (kW)	IPT (kW)	CAP (kW)	IPT (kW)	CAP (kW)	IPT (kW)	CAP (kW)	IPT (kW)	CAP (kW)	IPT (kW)
RAS-5WH(V)NPE + RWD-2.0NW(S) E-(200/260)S(-K)	60	-	-	-	-	7.47	5.45	8.19	5.97	8.16	5.27	8.14	4.72	11.20	5.62	11.40	5.33	12.00	5.43	14.00	6.08
	55	-	-	-	-	9.22	6.36	11.20	6.22	12.21	6.24	12.96	6.22	15.20	6.30	16.00	5.71	16.50	5.37	16.70	3.86
	50	-	-	-	-	9.99	5.81	11.42	5.87	12.45	5.64	13.27	5.45	15.46	5.41	16.50	4.93	16.80	4.55	17.10	3.92
	45	8.10	4.54	9.43	4.90	10.76	5.27	11.60	5.50	12.68	5.04	13.59	4.69	15.70	4.53	17.00	4.15	17.50	3.86	18.00	3.51
	40	8.90	4.61	10.02	4.81	11.15	5.00	11.82	5.12	12.89	4.75	13.75	4.45	16.13	4.10	17.15	3.77	17.70	3.56	18.50	3.19
	35	9.70	4.69	10.62	4.71	11.53	4.74	12.00	4.72	13.10	4.46	13.90	4.21	16.70	3.70	17.30	3.39	17.80	3.24	18.80	3.55
	30	10.70	4.74	11.28	4.55	11.85	4.35	12.20	4.24	13.26	4.18	14.10	4.14	17.20	3.58	17.90	3.03	17.96	2.63	19.10	3.38
	25	11.16	4.42	12.25	4.42	13.34	4.42	14.00	4.42	14.70	4.32	15.27	4.24	17.90	3.51	18.50	3.08	18.80	2.82	19.50	3.13
	20	11.61	4.10	13.22	4.30	14.83	4.49	15.80	4.60	16.15	4.46	16.43	4.34	18.10	3.33	18.80	3.08	19.00	2.90	20.00	2.71
RAS-6WH(V)NPE + RWD-2.0NW(S) E-(200/260)S(-K)	60	-	-	-	-	7.80	5.57	8.30	5.72	9.02	5.35	9.60	5.05	12.00	5.71	12.10	5.50	13.00	5.75	15.00	6.37
	55	-	-	-	-	10.38	7.39	12.00	7.18	12.96	7.09	13.96	7.16	17.00	7.13	17.20	6.14	17.30	5.56	17.40	4.60
	50	-	-	-	-	10.77	6.39	11.83	6.32	12.98	6.19	13.90	6.09	17.10	6.19	17.30	5.92	17.50	5.77	18.00	5.56
	45	9.00	4.86	10.32	5.34	11.63	5.81	12.50	6.13	13.56	5.68	14.48	5.36	17.30	5.33	17.50	4.49	18.00	4.14	18.60	3.51
	40	9.55	5.12	10.75	5.33	11.95	5.54	12.67	5.66	13.81	5.31	14.73	5.02	17.55	4.69	18.10	4.12	18.30	3.76	19.00	3.24
	35	10.10	5.37	11.18	5.32	12.27	5.26	13.00	5.27	14.06	4.93	15.00	4.69	17.80	4.05	18.20	3.64	18.60	3.54	19.60	3.43
	30	10.71	4.56	12.57	4.84	13.99	4.93	14.83	4.99	15.12	4.72	15.35	4.51	18.10	3.77	18.60	3.15	19.10	3.14	20.00	3.13
	25	11.30	4.48	12.83	4.63	14.02	4.64	14.73	4.65	15.18	4.47	15.54	4.33	18.50	3.78	19.90	3.37	20.50	3.27	21.00	3.05
	20	12.13	4.48	13.09	4.42	14.05	4.36	14.63	4.32	15.24	4.22	15.72	4.15	18.90	3.78	20.90	3.54	21.10	3.31	22.00	3.04



NOTE

- CAP: Capacity at compressor maximum frequency. Capacity is valid for difference between water inlet and water outlet of 3-8°C.
- IPT: Total input power.

The table above shows the input power (IPT) at maximum capacity (CAP). Most of the time, the unit will run at partial load, so that the actual input power will be lower.

4.4.2 Maximum cooling capacity table (kW)

System	Water outlet temperature (°C)	Ambient temperature (°C DB)							
		10	15	20	25	30	35	40	45
		CAP (kW)	CAP (kW)	CAP (kW)	CAP (kW)	CAP (kW)	CAP (kW)	CAP (kW)	CAP (kW)
RAS-2WHVNP + RWD-2.0NW(S) E-(200/260)S(-K)	20	-	-	-	6.7	6.4	6.0	5.7	5.4
	18	-	-	7.1	6.6	6.3	6.1	5.6	5.0
	15	6.1	6.2	6.2	6.3	5.9	5.5	5.2	4.8
	10	5.8	5.7	5.7	5.7	5.4	5.1	4.8	4.6
	7	5.5	5.6	5.4	5.3	5.1	4.9	4.7	4.4
RAS-2.5WHVNP + RWD-2.5NW(S) E-(200/260)S(-K)	20	-	-	-	7.6	7.2	6.9	6.5	6.1
	18	-	-	8.5	8.0	7.8	7.4	6.6	5.7
	15	8.4	8.1	7.8	7.6	7.1	6.6	6.1	5.6
	10	7.5	7.3	7.0	6.8	6.5	6.1	5.8	5.4
	7	7.0	6.8	6.5	6.4	6.1	5.8	5.6	5.3
RAS-3WHVNP + RWD-3.0NW(S) E-(200/260)S(-K)	20	-	-	-	8.9	8.4	8.0	7.5	7.0
	18	-	-	9.0	8.9	8.7	8.5	7.5	6.5
	15	8.9	8.8	8.6	8.5	7.9	7.4	6.9	6.4
	10	8.6	8.3	8.0	7.8	7.4	6.9	6.5	6.1
	7	8.2	8.1	7.8	7.3	7.2	7.0	6.5	6.0
RAS-4WH(V)NPE + RWD-4.0NW(S) E-(200/260)S(-K)	20	-	-	-	16.1	15.7	15.2	14.8	14.3
	18	-	-	17.0	16.1	15.1	15.0	14.4	13.7
	15	16.0	15.8	15.5	15.3	14.6	14.0	13.3	12.7
	10	15.1	14.7	14.4	14.0	13.2	12.5	11.7	11.0
	7	14.0	13.9	13.4	13.2	12.3	11.8	10.9	9.9
RAS-5WH(V)NPE + RWD-5.0NW(S) E-(200/260)S(-K)	20	-	-	-	18.3	18.0	17.7	17.3	17.0
	18	-	-	18.5	17.6	17.4	16.0	15.0	14.0
	15	17.1	17.1	17.0	17.1	16.1	15.1	14.1	13.0
	10	16.6	16.5	16.4	16.2	15.0	13.8	12.6	11.4
	7	16.1	15.9	15.4	15.7	13.2	12.6	11.5	10.4
RAS-6WH(V)NPE + RWD-6.0NW(S) E-(200/260)S(-K)	20	-	-	-	20.0	19.6	19.3	18.9	18.5
	18	-	-	20.0	19.0	17.8	17.5	17.3	16.8
	15	18.0	18.1	18.2	18.3	17.5	16.8	16.0	15.2
	10	17.5	17.4	17.2	17.1	16.0	14.9	13.7	12.6
	7	17.0	16.8	16.3	16.4	14.9	13.7	12.4	11.0

**NOTE**

CAP: Capacity at compressor maximum frequency. Capacity is valid for difference between water inlet and water outlet of 3-8 °C.

4.5 YUTAKI S 80

4.5.1 Maximum heating capacity table (kW) (Integrated)

System	Water outlet temp. (°C)	Ambient temperature (°C WB)																			
		-20		-15		-10		-7		-2		2		7		12		15		20	
		CAP (kW)	IPT (kW)	CAP (kW)	IPT (kW)	CAP (kW)	IPT (kW)	CAP (kW)	IPT (kW)	CAP (kW)	IPT (kW)	CAP (kW)	IPT (kW)	CAP (kW)	IPT (kW)	CAP (kW)	IPT (kW)	CAP (kW)	IPT (kW)	CAP (kW)	IPT (kW)
RAS-4WH(V) NPE + RWH-4.0VNF(W)E	80	10.60	6.42	11.10	6.50	10.80	6.28	11.90	6.61	11.84	6.12	11.79	5.73	13.50	5.87	14.50	5.69	15.10	5.58	16.10	5.39
	75	10.73	6.26	11.26	6.35	11.23	6.29	12.10	6.49	12.14	6.10	12.17	5.78	13.83	5.89	14.67	5.68	15.17	5.55	16.01	5.35
	70	10.91	6.05	11.47	6.16	11.81	6.30	12.37	6.33	12.54	6.06	12.68	5.85	14.27	5.91	14.89	5.67	15.26	5.52	15.88	5.28
	65	11.00	5.95	11.58	6.06	12.10	6.30	12.50	6.25	12.74	6.05	12.94	5.89	14.49	5.92	15.00	5.66	15.31	5.51	15.82	5.25
	60	11.15	5.92	11.67	6.00	12.16	6.15	12.50	6.14	12.90	6.07	13.22	6.01	14.49	5.46	15.00	5.25	15.31	5.13	15.81	4.38
	55	11.30	5.89	11.76	5.94	12.22	6.00	12.50	6.04	13.06	6.09	13.64	6.55	14.49	5.00	15.00	4.84	15.30	4.74	15.81	3.50
	50	11.90	6.07	12.22	6.02	12.39	5.93	12.50	5.84	12.98	5.61	13.66	5.80	14.50	4.84	15.20	4.84	15.62	4.84	16.32	4.84
	45	12.50	6.25	12.50	6.03	12.50	5.81	12.50	5.68	13.02	5.38	13.78	5.49	14.50	4.53	15.30	4.64	15.78	4.70	16.58	4.80
	40	11.14	5.59	11.11	5.24	11.09	4.89	11.08	4.67	12.08	4.69	12.51	4.41	14.85	3.90	15.65	3.86	16.13	3.83	16.93	3.79
	35	9.00	4.29	9.62	4.18	10.25	4.08	10.62	4.01	11.83	4.08	12.80	4.13	15.20	3.27	16.00	3.08	16.48	2.96	17.50	2.81
	30	10.00	4.34	10.77	4.22	11.53	4.10	11.99	4.03	12.72	3.90	13.30	3.80	15.90	3.31	16.60	2.81	17.02	2.51	17.72	2.60
	25	11.64	4.44	12.16	4.31	12.68	4.18	13.00	4.10	13.72	3.98	13.58	3.61	16.10	2.82	17.00	2.74	17.54	2.69	18.44	2.55
20	13.28	4.55	13.56	4.40	13.84	4.26	14.00	4.18	14.72	4.06	13.78	3.46	16.30	2.34	17.40	2.67	18.06	2.87	19.16	2.50	
RAS-5WH(V) NPE + RWH-5.0VNF(W)E	80	11.65	7.28	12.13	7.32	12.70	7.47	12.90	7.37	13.12	7.17	13.30	7.00	15.00	6.82	16.50	6.60	17.40	6.47	18.90	6.25
	75	12.43	7.60	12.82	7.52	13.20	7.58	13.43	7.39	13.62	7.24	13.77	7.12	15.63	6.85	16.83	6.64	17.56	6.52	18.76	6.31
	70	13.48	8.02	13.73	7.79	13.87	7.73	14.14	7.42	14.28	7.34	14.39	7.27	16.46	6.89	17.28	6.70	17.77	6.59	18.58	6.39
	65	14.00	8.24	14.19	7.93	14.20	7.80	14.50	7.44	14.61	7.39	14.70	7.35	16.88	6.92	17.50	6.73	17.87	6.62	18.49	6.44
	60	14.10	7.96	14.25	7.65	14.32	7.44	14.50	7.17	14.89	7.26	15.20	7.33	16.95	6.61	17.50	6.38	17.83	6.25	18.38	6.02
	55	14.20	7.68	14.32	7.38	14.43	7.08	14.50	6.90	15.17	7.13	15.70	7.30	17.02	6.30	17.50	6.03	17.79	5.87	18.27	5.61
	50	14.35	7.56	14.42	7.37	14.44	7.17	14.50	6.99	14.88	6.81	15.19	6.66	16.98	5.98	17.50	5.89	17.81	5.84	18.33	5.75
	45	14.50	7.44	14.50	7.23	14.50	7.03	14.50	6.90	14.88	6.59	15.18	6.33	17.00	5.67	17.50	5.65	17.80	5.63	18.30	5.61
	40	12.10	6.06	12.56	5.97	13.02	5.88	13.29	5.83	13.99	5.52	14.55	5.28	16.76	4.66	17.40	4.52	17.79	4.43	18.43	4.29
	35	9.70	4.69	10.62	4.71	11.53	4.74	12.00	4.72	13.10	4.46	13.90	4.21	16.70	3.70	17.30	3.39	17.80	3.24	18.80	3.55
	30	10.70	4.74	11.28	4.55	11.85	4.35	12.20	4.24	13.26	4.18	14.10	4.14	17.20	3.58	17.90	3.03	17.96	2.63	19.10	3.38
	25	11.16	4.42	12.25	4.42	13.34	4.42	14.00	4.42	14.70	4.32	15.27	4.24	17.90	3.51	18.50	3.08	18.80	2.82	19.50	3.13
20	11.61	4.10	13.22	4.30	14.83	4.49	15.80	4.60	16.15	4.46	16.43	4.34	18.10	3.33	18.80	3.08	19.00	2.90	20.00	2.71	
RAS-6WH(V) NPE + RWH-6.0VNF(W)E	80	12.70	8.47	13.01	8.36	14.70	9.19	13.50	8.18	13.78	7.84	14.00	7.57	16.00	7.62	17.50	7.29	18.40	7.10	19.90	6.77
	75	13.40	8.73	13.76	8.52	14.90	9.12	14.33	8.19	14.70	8.02	15.00	7.88	16.64	7.63	17.77	7.30	18.44	7.11	19.57	6.78
	70	14.33	9.08	14.76	8.74	15.17	9.04	15.44	8.20	15.94	8.25	16.33	8.29	17.50	7.64	18.12	7.31	18.50	7.12	19.13	6.80
	65	14.80	9.25	15.26	8.85	15.30	9.00	16.00	8.21	16.56	8.37	17.00	8.50	17.92	7.64	18.30	7.32	18.53	7.13	18.90	6.81
	60	14.95	8.82	15.37	8.59	15.58	8.64	16.05	8.23	16.38	8.28	16.65	8.33	17.92	6.91	18.65	7.11	19.09	7.24	19.81	7.45
	55	15.10	8.39	15.48	8.34	15.87	8.29	16.10	8.26	16.21	8.20	16.30	8.15	17.92	6.17	19.00	6.91	19.65	7.35	20.72	8.09
	50	15.55	8.64	15.78	8.59	16.01	8.40	16.15	8.14	16.37	7.82	16.54	7.56	17.97	6.67	18.88	6.59	19.43	6.55	20.34	6.48
	45	16.00	8.89	16.08	8.59	16.15	8.28	16.20	8.10	16.36	7.58	16.49	7.17	18.00	6.55	19.00	6.33	19.60	6.21	20.60	5.99
	40	13.05	7.13	13.63	6.95	14.21	6.77	14.56	6.67	15.22	6.26	15.75	5.93	17.88	5.29	18.60	4.99	19.03	4.80	19.76	4.50
	35	10.10	5.37	11.18	5.32	12.27	5.26	13.00	5.27	14.06	4.93	15.00	4.69	17.80	4.05	18.20	3.64	18.60	3.54	19.60	3.43
	30	10.71	4.56	12.57	4.84	13.99	4.93	14.83	4.99	15.12	4.72	15.35	4.51	18.10	3.77	18.60	3.15	19.10	3.14	20.00	3.13
	25	11.30	4.48	12.83	4.63	14.02	4.64	14.73	4.65	15.18	4.47	15.54	4.33	18.50	3.78	19.90	3.37	20.50	3.27	21.00	3.05
20	12.13	4.48	13.09	4.42	14.05	4.36	14.63	4.32	15.24	4.22	15.72	4.15	18.90	3.78	20.90	3.54	21.10	3.31	22.00	3.04	



NOTE

- CAP: Capacity at compressor maximum frequency (kW). Capacity is valid for difference between water inlet and water outlet of 3-10°C.
 - IPT: Total input power (kW).
- The table above shows the input power (IPT) at maximum capacity (CAP). Most of the time, the unit will run at partial load, so that the actual input power will be lower.



4.6 YUTAKI M

4.6.1 Maximum heating capacity table (kW) (Integrated)

System	Water outlet temp (°C)	Ambient temperature (°C WB)																			
		-20		-15		-10		-7		-2		2		7		12		15		20	
		CAP (kW)	IPT (kW)	CAP (kW)	IPT (kW)	CAP (kW)	IPT (kW)	CAP (kW)	IPT (kW)	CAP (kW)	IPT (kW)	CAP (kW)	IPT (kW)	CAP (kW)	IPT (kW)	CAP (kW)	IPT (kW)	CAP (kW)	IPT (kW)	CAP (kW)	IPT (kW)
RASM-3VNE	60	-	-	-	-	-	-	-	-	-	-	-	-	-	-	-	-	-	-	-	-
	55	-	-	-	-	4.50	3.21	5.50	3.55	6.33	3.46	7.00	3.40	9.20	3.83	10.50	3.68	11.00	3.57	11.40	3.28
	50	-	-	-	-	5.46	3.45	6.05	3.58	6.82	3.48	7.44	3.40	9.86	3.61	10.70	3.49	11.20	3.49	11.62	3.37
	45	-	-	5.50	3.33	5.70	2.93	6.40	3.04	7.14	3.01	7.70	2.96	10.00	3.22	11.00	2.89	11.50	2.82	11.70	2.56
	40	-	-	5.62	3.10	6.00	2.82	6.58	2.93	7.53	2.91	8.30	2.89	10.49	2.95	11.50	2.70	11.80	2.59	11.90	2.36
	35	-	-	5.90	2.95	6.40	2.85	6.71	2.80	7.92	2.81	8.90	2.83	11.00	2.68	11.70	2.44	11.90	2.34	12.10	2.16
	30	-	-	6.10	2.84	6.66	2.68	7.00	2.59	8.10	2.61	9.40	2.76	11.10	2.52	12.00	2.11	12.10	1.95	12.30	1.74
	25	-	-	6.50	2.61	6.90	2.43	7.10	2.31	8.30	2.40	10.20	2.71	11.30	2.22	12.10	2.16	12.30	2.11	12.40	2.00
	20	-	-	7.00	2.42	7.10	2.17	7.20	2.03	8.50	2.15	10.30	2.41	11.50	1.91	12.20	2.22	12.40	2.27	12.60	2.32
RASM-4(V)NE	60	-	-	-	-	6.50	4.33	6.80	4.12	6.91	3.60	7.00	3.18	8.50	3.40	10.20	3.64	11.22	3.79	13.00	4.06
	55	-	-	-	-	7.20	4.30	9.70	5.56	9.90	4.86	10.50	4.47	13.50	4.75	14.36	5.16	14.77	5.37	15.46	3.50
	50	-	-	-	-	7.79	3.95	9.87	4.50	10.00	4.16	10.90	4.19	13.88	4.33	14.83	4.45	15.39	4.51	16.34	4.63
	45	7.20	4.03	8.28	4.05	9.35	4.07	10.00	4.08	10.60	3.95	11.50	3.97	14.10	3.85	15.30	3.73	16.02	3.66	17.00	3.49
	40	8.10	4.16	8.95	4.12	9.80	4.07	10.31	4.05	11.00	3.93	11.80	3.92	14.65	3.56	15.65	3.40	16.25	3.31	17.25	3.15
	35	9.00	4.29	9.62	4.18	10.25	4.08	10.62	4.01	11.83	4.08	12.80	4.13	15.20	3.27	16.00	3.08	16.48	2.96	17.50	2.81
	30	10.00	4.34	10.77	4.22	11.53	4.10	11.99	4.03	12.72	3.90	13.30	3.80	15.90	3.31	16.60	2.81	17.02	2.51	17.72	2.60
	25	11.64	4.44	12.16	4.31	12.68	4.18	13.00	4.10	13.72	3.98	13.58	3.61	16.10	2.82	17.00	2.74	17.54	2.69	18.44	2.55
	20	13.28	4.55	13.56	4.40	13.84	4.26	14.00	4.18	14.72	4.06	13.78	3.46	16.30	2.34	17.40	2.67	18.06	2.87	19.16	2.50
RASM-5(V)NE	60	-	-	-	-	7.47	5.45	8.19	5.97	8.16	5.27	8.14	4.72	11.20	5.62	11.40	5.33	12.00	5.43	14.00	6.08
	55	-	-	-	-	9.22	6.36	11.20	6.22	12.21	6.24	12.96	6.22	15.20	6.30	16.00	5.71	16.50	5.37	16.70	3.86
	50	-	-	-	-	9.99	5.81	11.42	5.87	12.45	5.64	13.27	5.45	15.46	5.41	16.50	4.93	16.80	4.55	17.10	3.92
	45	8.10	4.54	9.43	4.90	10.76	5.27	11.60	5.50	12.68	5.04	13.59	4.69	15.70	4.53	17.00	4.15	17.50	3.86	18.00	3.51
	40	8.90	4.61	10.02	4.81	11.15	5.00	11.82	5.12	12.89	4.75	13.75	4.45	16.13	4.10	17.15	3.77	17.70	3.56	18.50	3.19
	35	9.70	4.69	10.62	4.71	11.53	4.74	12.00	4.72	13.10	4.46	13.90	4.21	16.70	3.70	17.30	3.39	17.80	3.24	18.80	3.55
	30	10.70	4.74	11.28	4.55	11.85	4.35	12.20	4.24	13.26	4.18	14.10	4.14	17.20	3.58	17.90	3.03	17.96	2.63	19.10	3.38
	25	11.16	4.42	12.25	4.42	13.34	4.42	14.00	4.42	14.70	4.32	15.27	4.24	17.90	3.51	18.50	3.08	18.80	2.82	19.50	3.13
	20	11.61	4.10	13.22	4.30	14.83	4.49	15.80	4.60	16.15	4.46	16.43	4.34	18.10	3.33	18.80	3.08	19.00	2.90	20.00	2.71
RASM-6(V)NE	60	-	-	-	-	7.80	5.57	8.30	5.72	9.02	5.35	9.60	5.05	12.00	5.71	12.10	5.50	13.00	5.75	15.00	6.37
	55	-	-	-	-	10.38	7.39	12.00	7.18	12.96	7.09	13.96	7.16	17.00	7.13	17.20	6.14	17.30	5.56	17.40	4.60
	50	-	-	-	-	10.77	6.39	11.83	6.32	12.98	6.19	13.90	6.09	17.10	6.19	17.30	5.92	17.50	5.77	18.00	5.56
	45	9.00	4.86	10.32	5.34	11.63	5.81	12.50	6.13	13.56	5.68	14.48	5.36	17.30	5.33	17.50	4.49	18.00	4.14	18.60	3.51
	40	9.55	5.12	10.75	5.33	11.95	5.54	12.67	5.66	13.81	5.31	14.73	5.02	17.55	4.69	18.10	4.12	18.30	3.76	19.00	3.24
	35	10.10	5.37	11.18	5.32	12.27	5.26	13.00	5.27	14.06	4.93	15.00	4.69	17.80	4.05	18.20	3.64	18.60	3.54	19.60	3.43
	30	10.71	4.56	12.57	4.84	13.99	4.93	14.83	4.99	15.12	4.72	15.35	4.51	18.10	3.77	18.60	3.15	19.10	3.14	20.00	3.13
	25	11.30	4.48	12.83	4.63	14.02	4.64	14.73	4.65	15.18	4.47	15.54	4.33	18.50	3.78	19.90	3.37	20.50	3.27	21.00	3.05
	20	12.13	4.48	13.09	4.42	14.05	4.36	14.63	4.32	15.24	4.22	15.72	4.15	18.90	3.78	20.90	3.54	21.10	3.31	22.00	3.04

NOTE

- CAP: Capacity at maximum compressor frequency (kW). Capacity is valid for difference between water inlet and water outlet of 3-8°C.
- IPT: Total input power (kW)

The table above shows the input power (IPT) at maximum capacity (CAP). Most of the time, the unit runs at partial load, so that the actual input is lower.

4.6.2 Maximum cooling capacity table (kW)

System	Water outlet temperature (°C)	Ambient temperature (°C DB)							
		10	15	20	25	30	35	40	45
		CAP (kW)	CAP (kW)	CAP (kW)	CAP (kW)	CAP (kW)	CAP (kW)	CAP (kW)	CAP (kW)
RASM-3VNE)	22	-	-	-	9.8	9.3	8.7	8.2	7.7
	18	-	-	9.9	9.8	9.6	9.4	8.3	7.2
	15	9.8	9.6	9.5	9.3	8.7	8.2	7.6	7.0
	10	9.5	9.2	8.8	8.5	8.1	7.6	7.2	6.8
	7	9.0	8.9	8.5	8.1	7.9	7.7	7.2	6.6
RASM-4(V)NE	22	-	-	-	19.8	18.7	17.6	16.5	15.4
	18	-	-	18.0	17.9	16.8	15.0	14.4	13.7
	15	18.0	17.7	17.4	17.1	16.0	14.9	13.8	12.7
	10	16.1	16.0	15.9	15.8	14.6	13.4	12.2	11.0
	7	15.8	15.1	14.6	15.0	13.3	11.8	10.9	9.9
RASM-5(V)NE)	22	-	-	-	22.3	21.2	20.1	19.1	18.0
	18	-	-	20.9	19.6	18.3	16.0	15.4	14.7
	15	20.8	20.1	19.3	18.7	17.4	16.2	14.9	13.7
	10	20.1	19.2	18.2	17.2	15.9	14.5	13.2	11.9
	7	18.8	18.1	17.0	16.4	14.6	12.6	11.7	10.8
RASM-6(V)NE)	22	-	-	-	23.5	22.4	21.2	20.1	19.0
	18	-	-	22.0	21.1	19.8	17.8	17.5	17.0
	15	22.1	21.4	20.7	20.1	19.0	18.0	17.0	16.0
	10	21.5	20.4	19.4	18.3	17.0	15.8	14.5	13.2
	7	20.0	19.3	18.1	17.3	15.5	13.7	12.6	11.5

**NOTE**

CAP: Capacity at compressor maximum frequency. Capacity is valid for difference between water inlet and water outlet of 3-8 °C.

4.7 Correction factors

4.7.1 Piping length correction factor

The correction factor is based on the equivalent piping length in metres (EL) and the height difference between outdoor unit and indoor unit in metres (H).

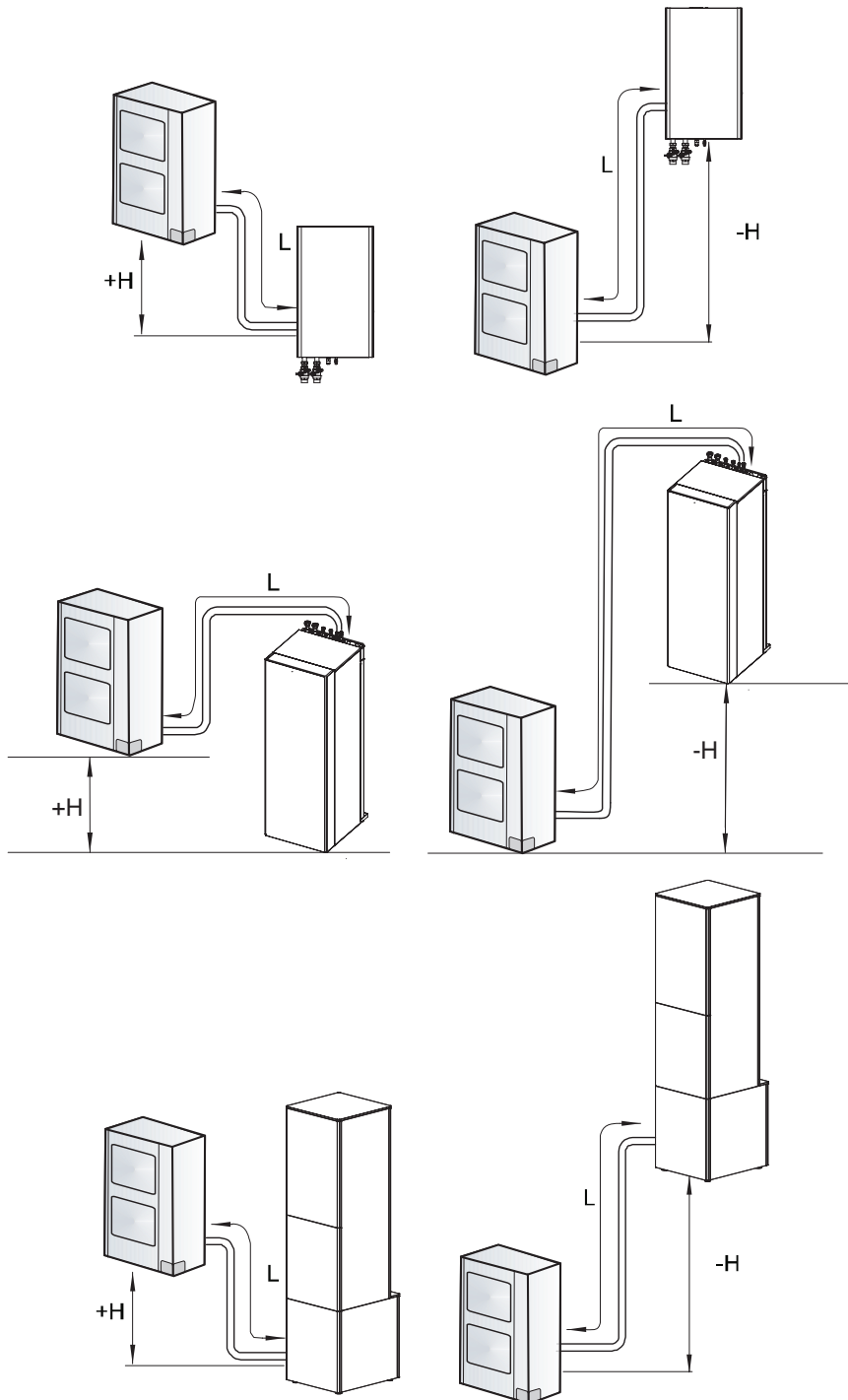

H: Height difference between indoor unit and outdoor unit (m).

- $H > 0$: Outdoor unit is placed higher than indoor unit (m).
- $H < 0$: Outdoor unit is placed lower than indoor unit (m).

L: Actual one-way piping length between indoor unit and outdoor unit (m).

EL: Equivalent one-way piping length between indoor unit and outdoor unit (m).

- One 90° elbow is 0.5 m.
- One 180° bend is 1.5 m.
- One Multi-kit is 0.5 m.

◆ Heating piping length correction factor

Heating

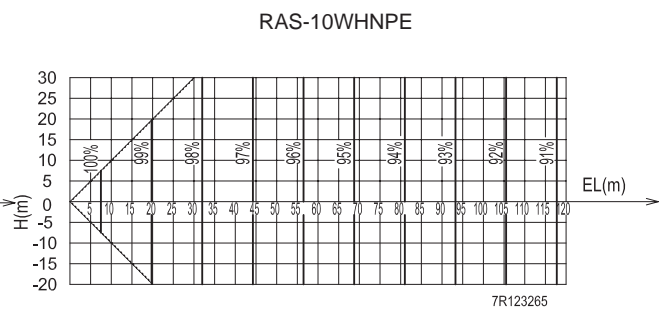
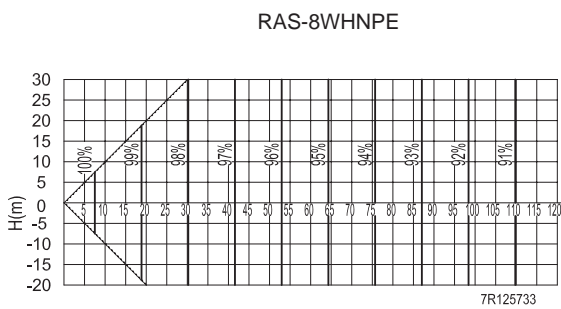
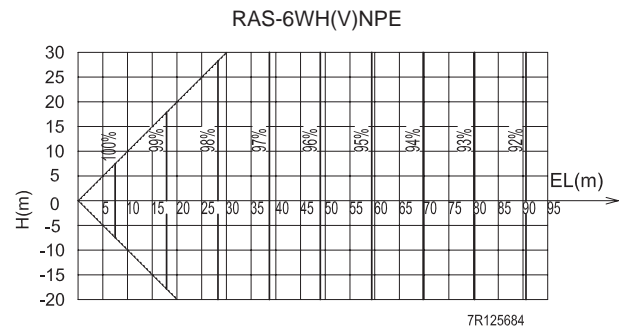
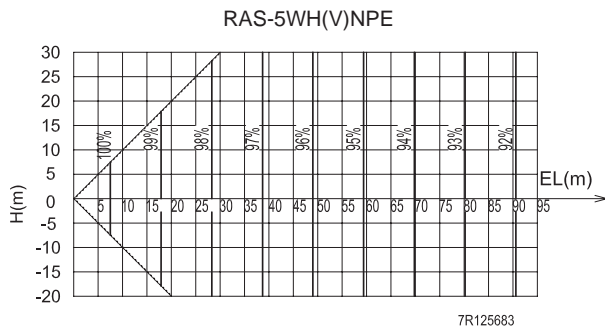
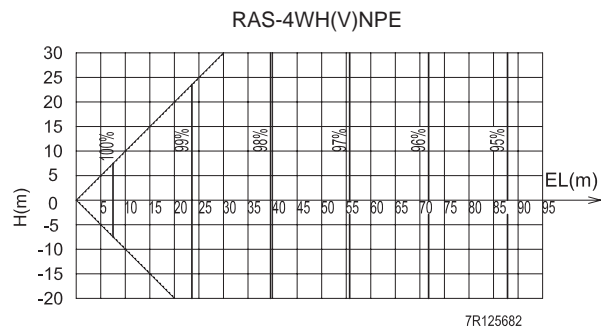
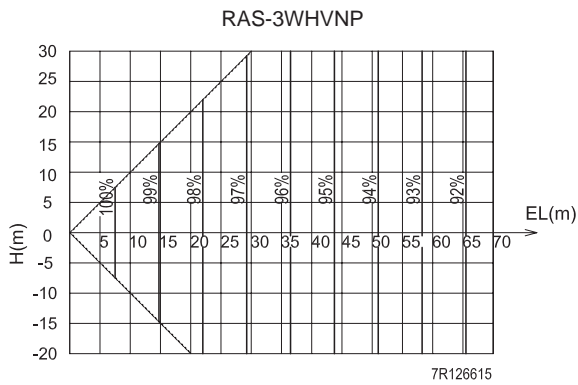
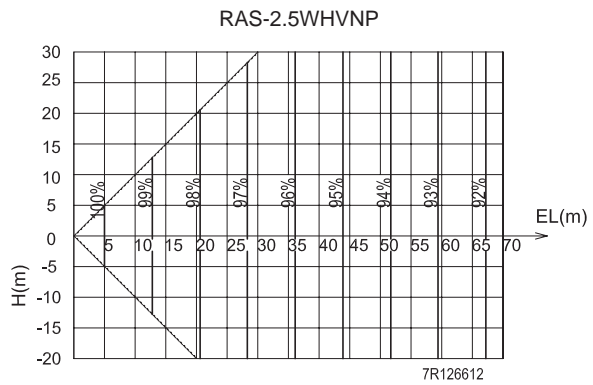
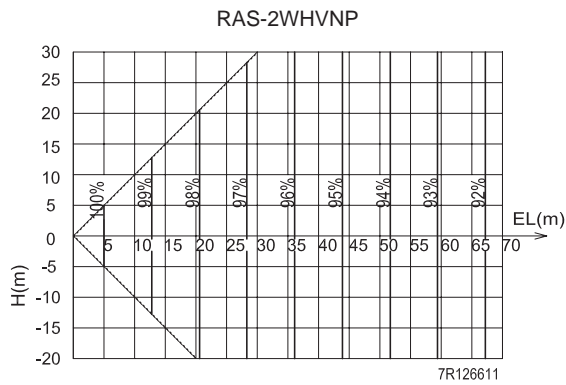

◆ Cooling piping length correction factor

Cooling

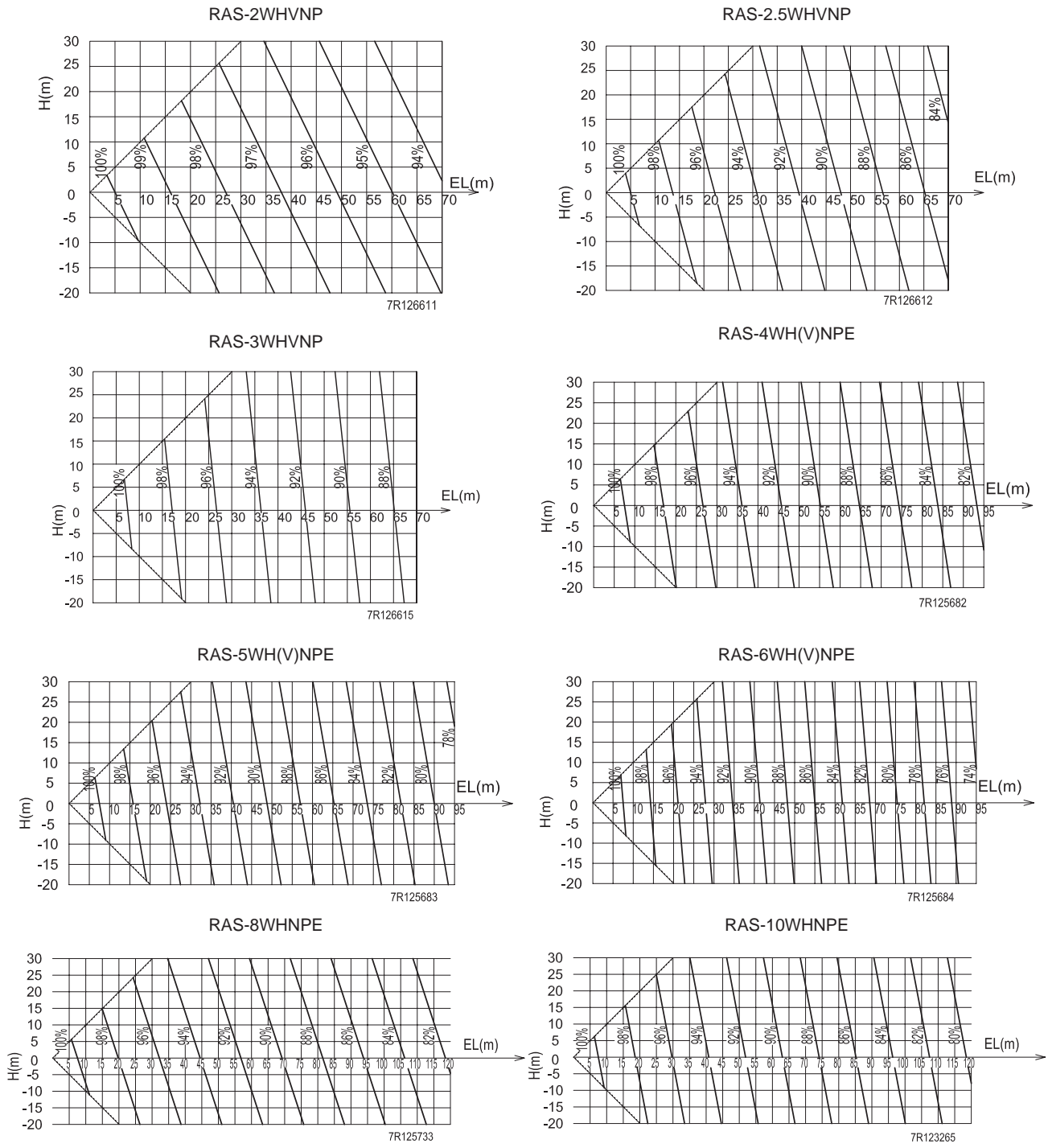

4.7.2 Correction factor owing to use of glycol (only for YUTAKI M)

◆ Application at low ambient temperature

When the ambient temperature is low in winter, the water in the pipes and circulating pump may freeze and damage the pipes and water pumps during shutdown periods.

To prevent this, it is useful to drain the water from the installation or not to cut off the power supply of the installation, as an electrical cable can prevent the water from freezing in the circuit.

In addition, in cases where it is difficult to drain the water, it is advisable to use a mixture with antifreeze glycol (ethylene or propylene at a concentration between 10% and 40%).

Unit performance may be reduced when operating with glycol, depending on the percentage of glycol used, since glycol is denser than water.

Two tables are shown below (one for ethylene glycol and the other for propylene glycol), indicating the percentage of ethylene glycol recommended for diverse values of outdoor air inlet temperature, with their respective correction factors.

Corrected heating capacity = capacity correction factor owing to use of glycol × heating capacity

- Ethylene glycol

Ambient Temperature	DB (°C)	-3	-7	-13	-22
Percentage of glycol required	%	10	20	30	40
Capacity correction factor	f_{gh}	1.00	1.00	0.99	0.99
Consumed power correction factor	f_{gi}	1.01	1.02	1.03	1.04
Flow rate correction factor	f_{gc}	1.01	1.01	1.02	1.04
Pressure loss correction factor	f_{gp}	1.03	1.09	1.16	1.26

- Propylene glycol

Ambient Temperature	DB (°C)	-3	-7	-13	-22
Percentage of glycol required	%	10	20	30	40
Capacity correction factor	f_{gh}	1.00	1.00	0.99	0.99
Consumed power correction factor	f_{gi}	1.01	1.02	1.03	1.04
Flow rate correction factor	f_{gc}	1.02	1.02	1.04	1.07
Pressure loss correction factor	f_{gp}	1.24	1.31	1.39	1.51

 **CAUTION**

The use of glycol affect to the reading of some parameters like "water flow level" and "capacity" shown through the unit controller menu. When glycol is used, these data are not correct and must be not used.

5. Acoustic characteristic curves

Index

5.1	Considerations	154
5.2	Sound pressure level for outdoor unit	155

5.1 Considerations

- 1 Distance of the unit from the measuring point: At 1 meter from the unit's front surface; 1,5 meter from floor level.

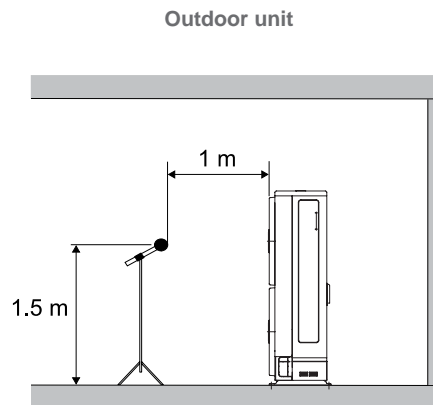

- 2 The data is measured in an anechoic chamber, so reflected sound should be taken into consideration when installing the unit.
- 3 The sound measured with the curve A shown in dB(A) represents the attenuation in function of frequency as perceived by the human ear.
- 4 Reference acoustic pressure 0 dB=20 μ Pa

5.2 Sound pressure level for outdoor unit

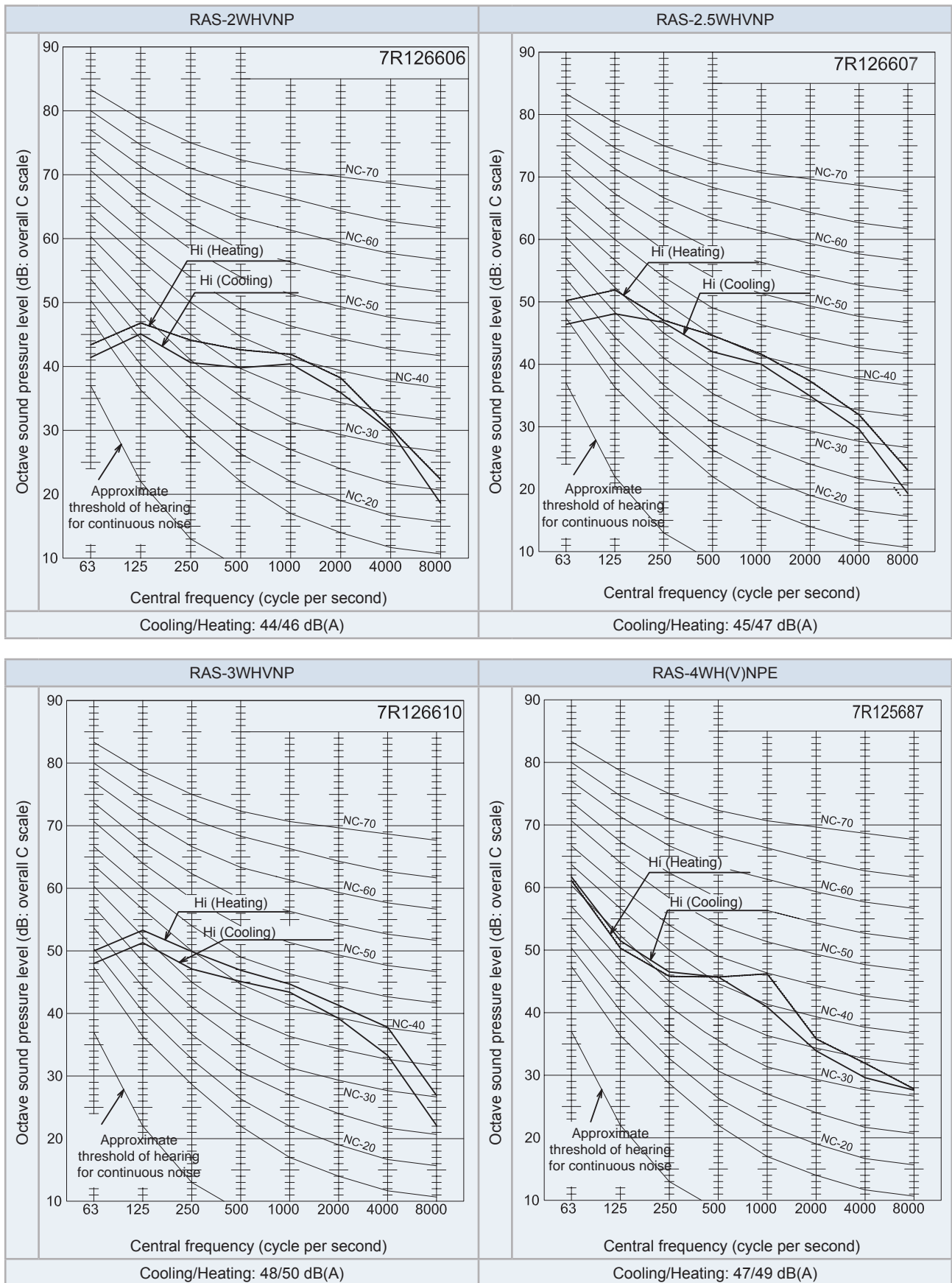

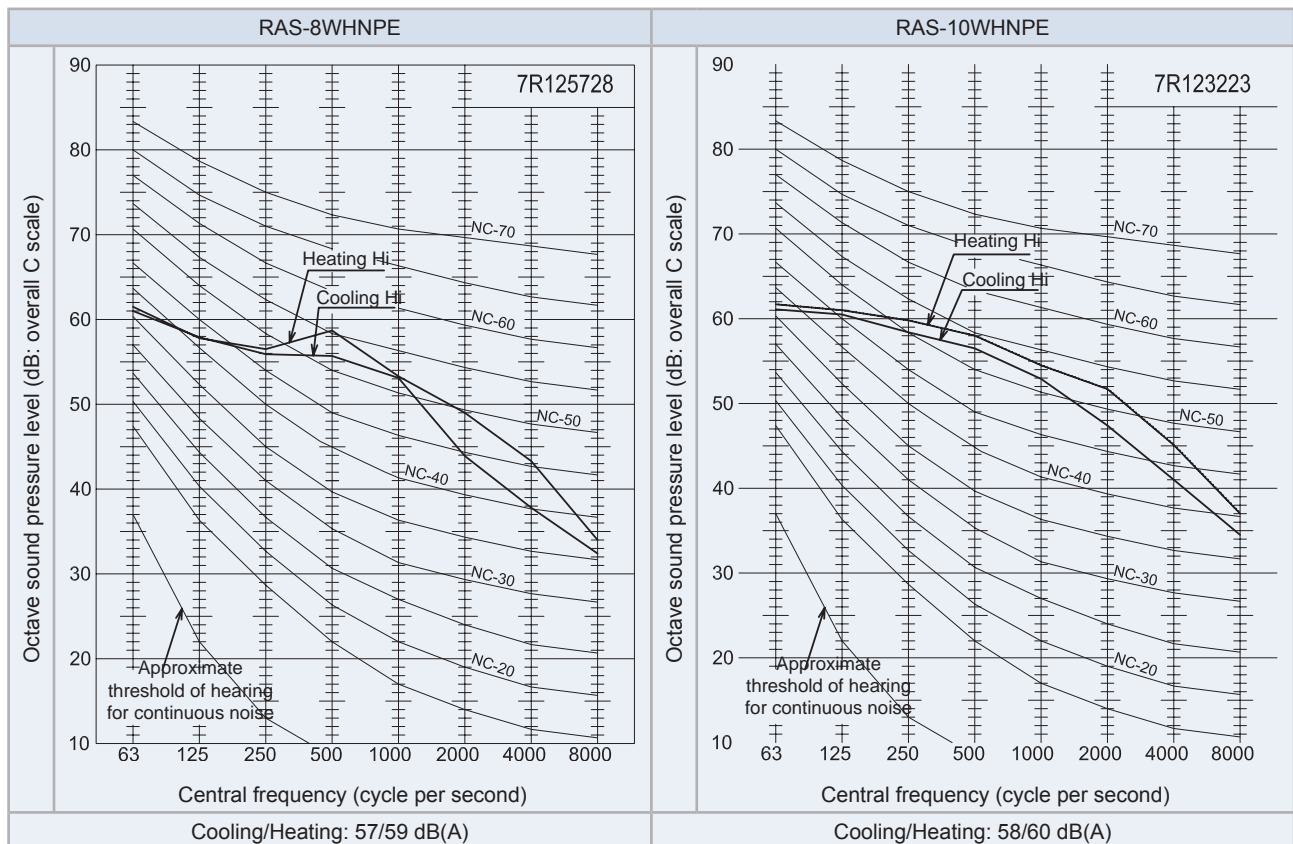
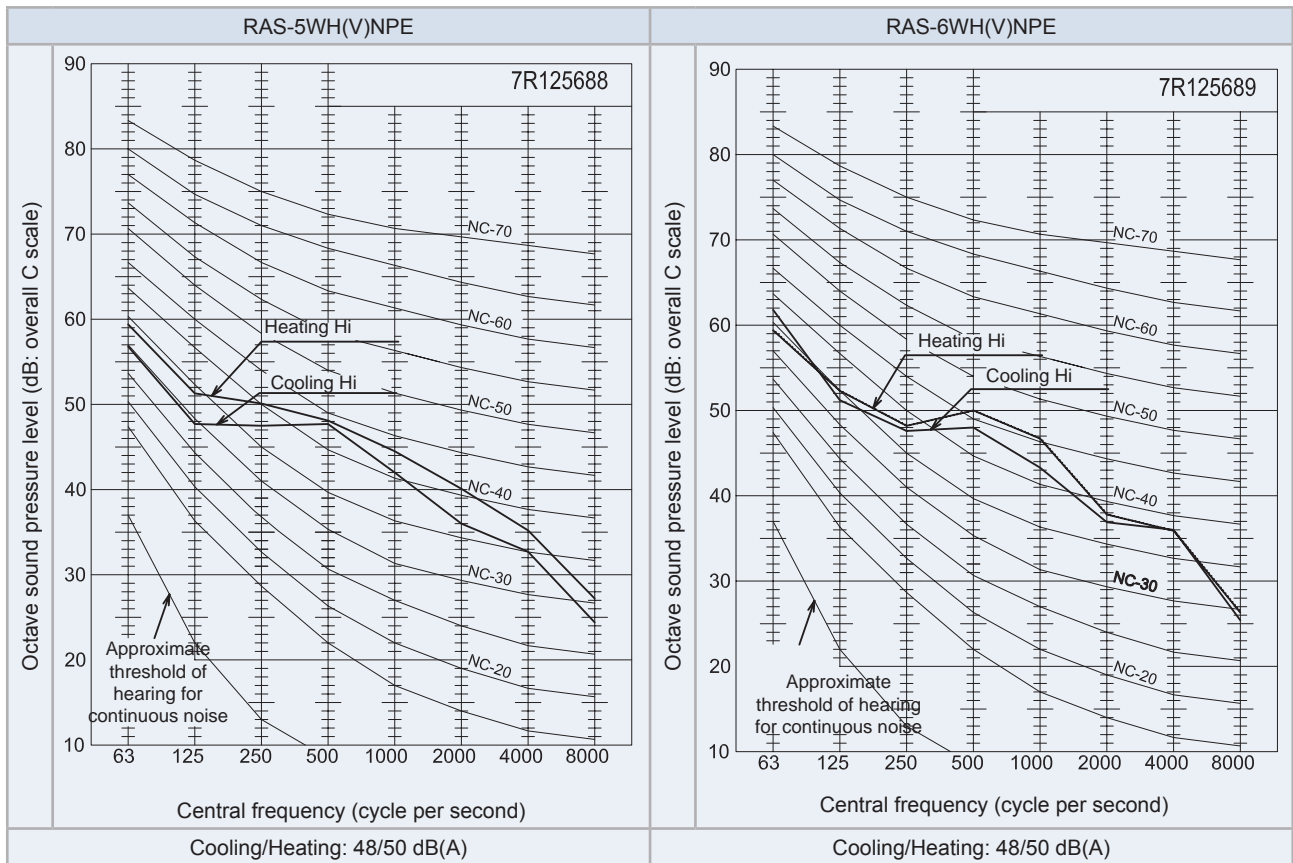

6 . Working range

Index

6.1	Power supply working range	158
6.2	Temperature working range.....	158
6.2.1	Space heating	158
6.2.2	DHW.....	160
6.2.3	Swimming pool heating	161
6.2.4	Space cooling (Necessary cooling kit)	161
6.3	Hydraulic working range.....	162
6.3.1	Hydraulic data	162
6.3.2	Pump performance curves	163

6.1 Power supply working range

- ◆ Nominal power supply
 - Single phase: 1~ 230V 50Hz
 - Three phase: 3N~ 400V 50Hz
- ◆ Operating voltage

Between 90 and 110% of the nominal voltage.

- ◆ Voltage imbalance for nominal power supply 3N~ 400V 50Hz

Up to 3% of each phase, measured at the main terminal of the outdoor unit.

- ◆ Starting voltage

Always higher than 85% of the nominal voltage.

6.2 Temperature working range

MODEL		2.0HP	2.5HP	3.0HP	4.0HP	5.0HP	6.0HP	8.0HP	10.0HP
Water temperature	°C	Refer to the graphics for each case							
Indoor ambient temperature		5~30							

6.2.1 Space heating

- ◆ YUTAKI (S / S COMBI)

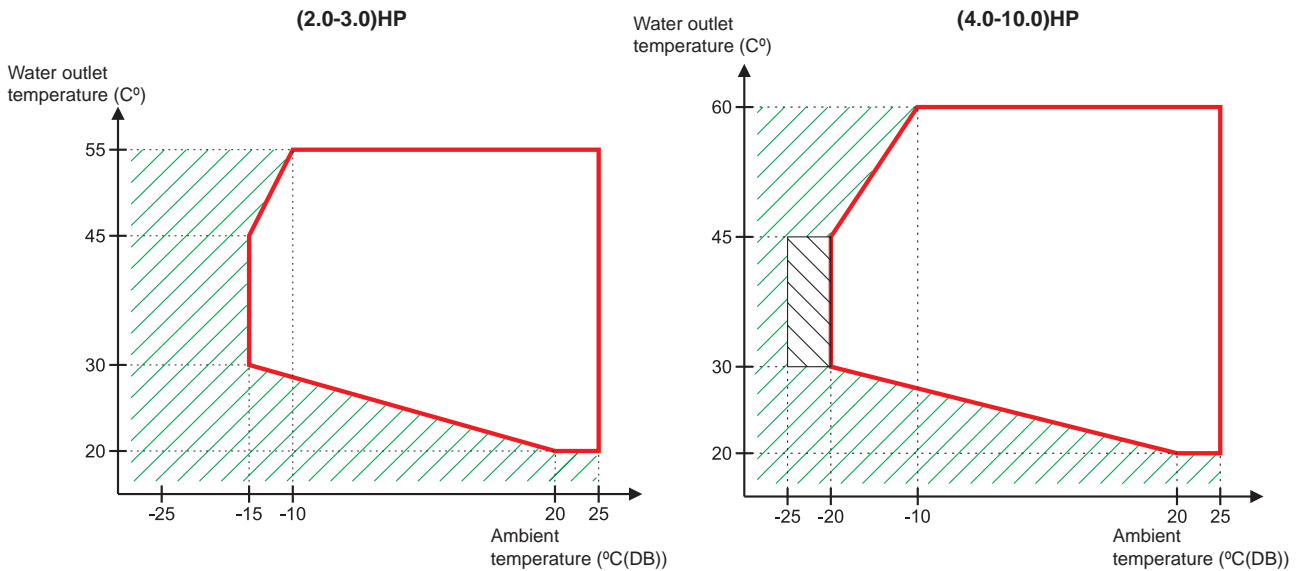

- Continuous working range.
- Outdoor unit operation is possible, but the capacity is not guaranteed. Indoor unit and back-up heater are operating.
- Only back-up heater. (No outdoor unit operation).

Temperature working range

◆ YUTAKI S80

Water outlet temperature (C°)

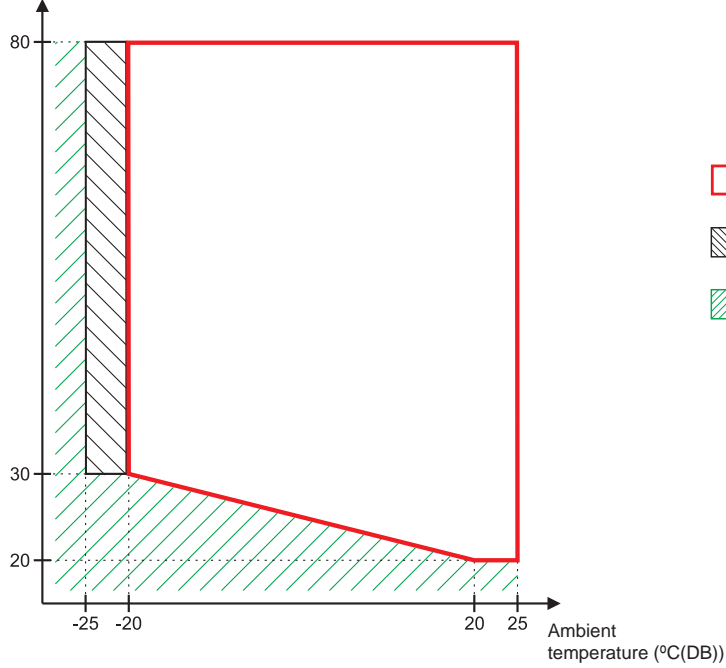

- Continuous working range.
- Outdoor unit operation is possible, but the capacity is not guaranteed. Indoor unit and back-up heater are operating.
- Only back-up heater. (No outdoor unit operation).

◆ YUTAKI M

Water outlet temperature (C°)

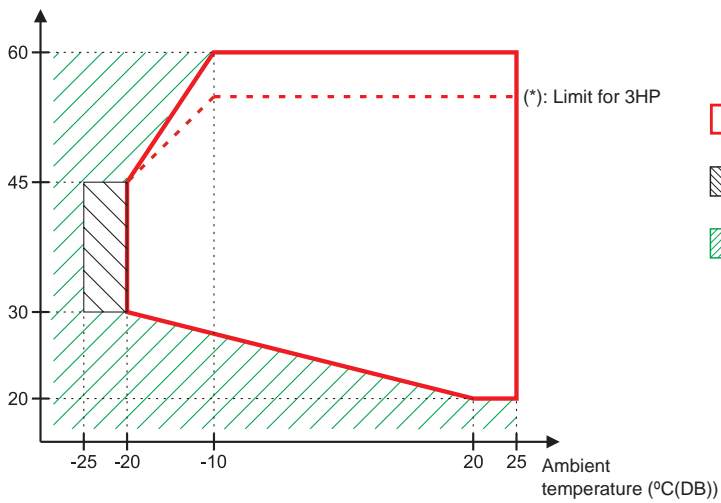

- Continuous working range.
- Outdoor unit operation is possible, but the capacity is not guaranteed. Indoor unit and back-up heater are operating.
- Only back-up heater. (No outdoor unit operation).



6.2.2 DHW

◆ For YUTAKI (S /S COMBI)

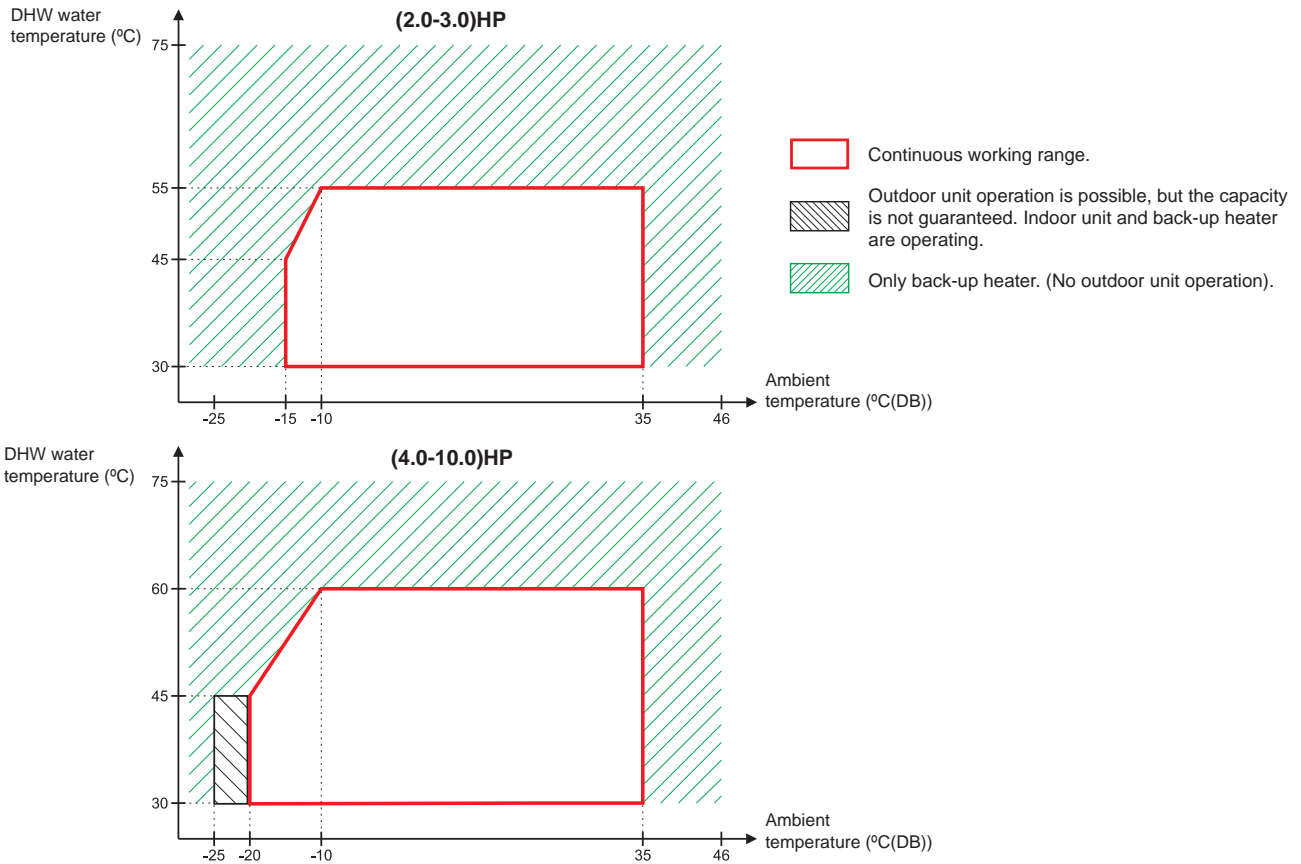

NOTE

- The heat pump can produce domestic hot water at 57° C as a maximum (53° C for 2.0/2.5/3.0HP) by itself, but HITACHI recommends to set the temperature of the tank by heat pump only up to 55° C (50° C for 2.0/2.5/3.0HP) and keep Thpoff default value. In case of higher setting, the tank's heater must be used to reach the setting temperature (enabled by optional function).
- In case of heating up the DHW tank with an outdoor ambient temperature lower than -10 °C and without using the DHW electrical heater, the setting temperature must not exceed the maximum value in the specified continuous working range.

◆ For YUTAKI S80

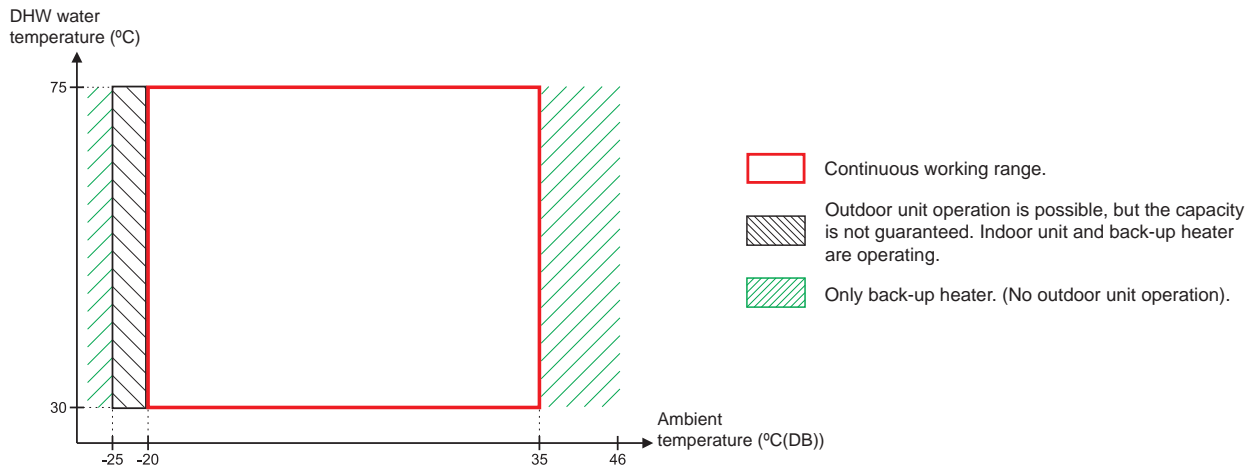

Temperature working range

◆ For YUTAKI M

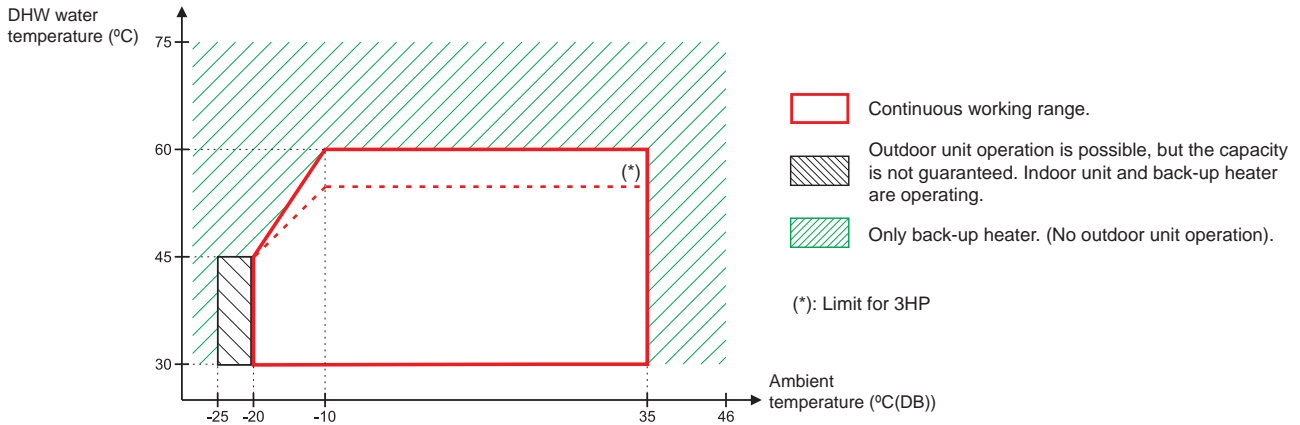

NOTE

- The heat pump can produce domestic hot water at 57° C as a maximum (53° C for 2.0/2.5/3.0HP) by itself, but HITACHI recommends to set the temperature of the tank by heat pump only up to 55° C (50° C for 2.0/2.5/3.0HP) and keep Thpoff default value. In case of higher setting, the tank's heater must be used to reach the setting temperature (enabled by optional function).
- In case of heating up the DHW tank with an outdoor ambient temperature lower than -10 °C and without using the DHW electrical heater, the setting temperature must not exceed the maximum value in the specified continuous working range.

6.2.3 Swimming pool heating

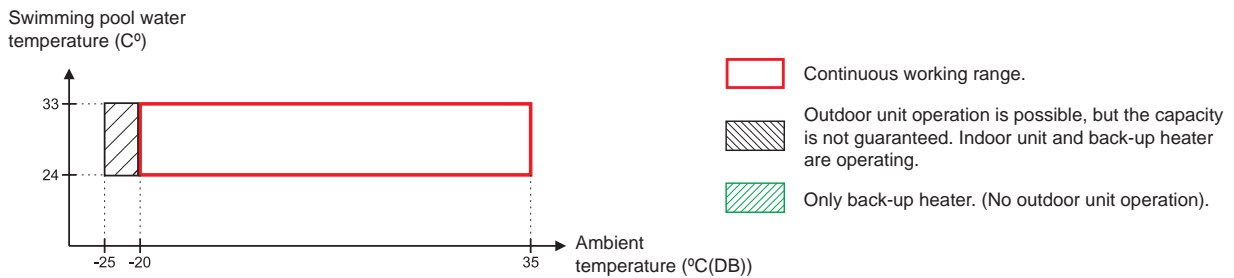

6.2.4 Space cooling (Necessary cooling kit)

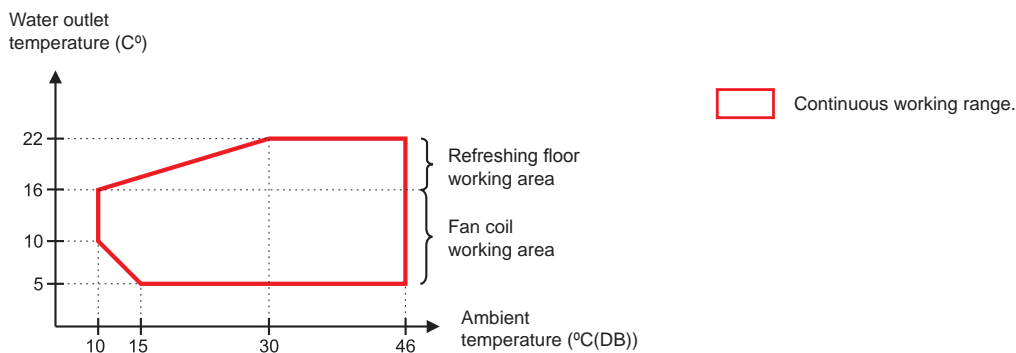

6.3 Hydraulic working range

6.3.1 Hydraulic data

◆ YUTAKI S

MODEL		2.0 HP	2.5 HP	3.0 HP	4.0 HP	5.0 HP	6.0 HP	8.0 HP	10.0 HP
Minimum water flow rate (*1)	m ³ /h	0.5	0.6	0.6	1.0	1.1	1.2	2.0	2.2
Maximum water flow rate (*1)	m ³ /h	1.9	2.0	2.1	2.9	3.0	3.0	4.5	4.6
Minimum installation water volume	l	28	28	28	38	46	55	76	79
Minimum allowable water pressure	MPa	0.1							
Maximum allowable water pressure	MPa	0.3							

◆ YUTAKI S COMBI

MODEL		2.0 HP	2.5 HP	3.0 HP	4.0 HP	5.0 HP	6.0 HP
Minimum water flow rate (*1)	m ³ /h	0.5	0.6	0.6	1.0	1.1	1.2
Maximum water flow rate (*1)	m ³ /h	1.8	1.9	1.9	2.7	2.8	2.8
Minimum installation water volume	l	28	28	28	38	46	55
Minimum allowable water pressure	MPa	0.1					
Maximum allowable water pressure	MPa	0.3					

◆ YUTAKI S80

MODEL		4.0 HP		5.0 HP		6.0 HP	
		Version for indoor unit alone	Version for combination with DHW tank	Version for indoor unit alone	Version for combination with DHW tank	Version for indoor unit alone	Version for combination with DHW tank
Minimum water flow rate (*1)	m ³ /h	1.0		1.1		1.2	
Maximum water flow rate (*1)	m ³ /h	2.8	2.5	3.2	2.7	3.2	2.7
Minimum installation water volume	l	40		50		50	
Minimum allowable water pressure	MPa	0.1					
Maximum allowable water pressure	MPa	0.3					

◆ YUTAKI M

MODEL		3.0 HP	4.0 HP	5.0 HP	6.0 HP
Minimum water flow rate (*1)	m ³ /h	0.6	1.0	1.1	1.2
Maximum water flow rate (*1)	m ³ /h	2.1	2.8	3.0	3.0
Minimum installation water volume	l	28	38	46	55
Minimum allowable water pressure	MPa	0.1			
Maximum allowable water pressure	MPa	0.3			



NOTE

- (*1): Values calculated based on a ΔT (inlet/outlet): 3~8 °C

6.3.2 Pump performance curves

i NOTE

If a water flow rate is selected out of the working range of the unit, it can cause malfunction on the unit. Please, try to operate the pump within the minimum and maximum water flow of the indoor unit.

◆ YUTAKI S

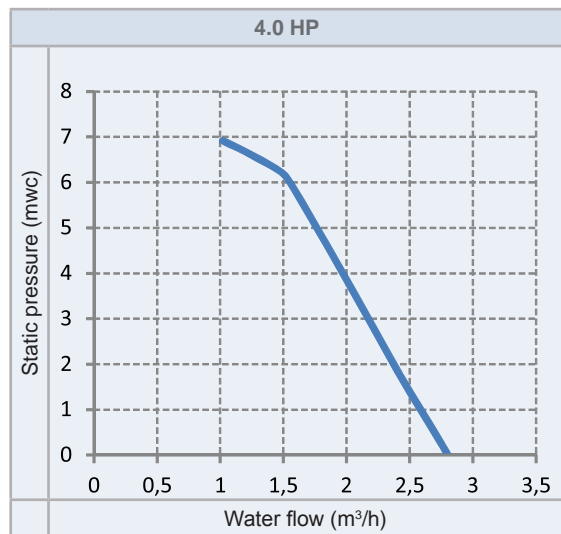
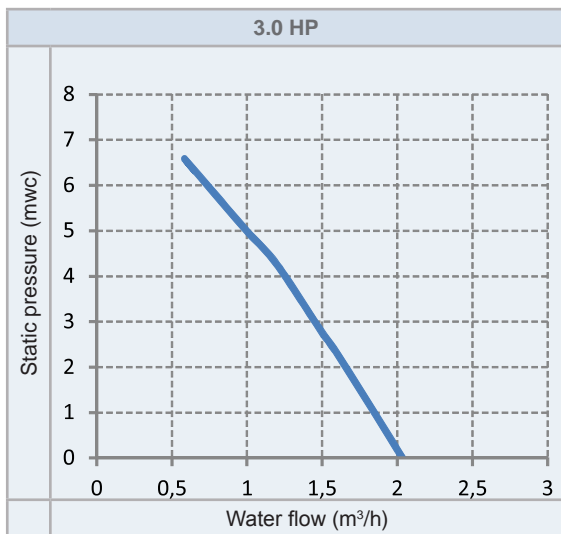
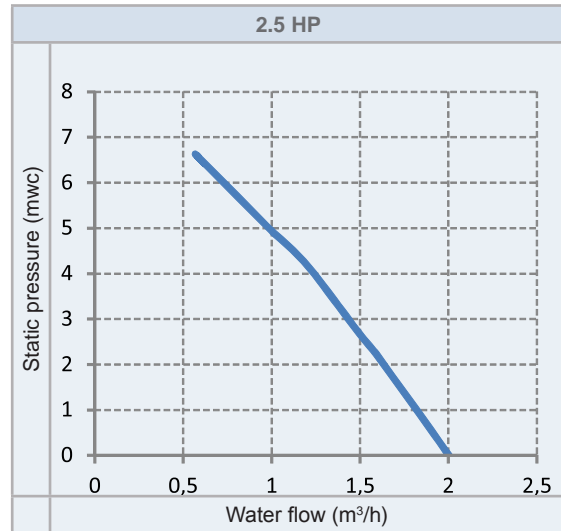
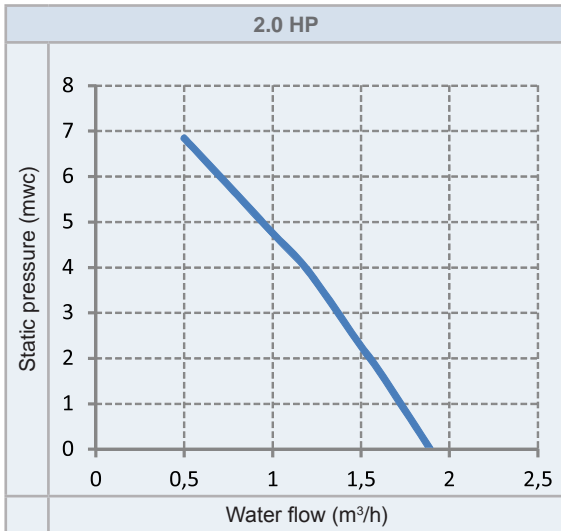

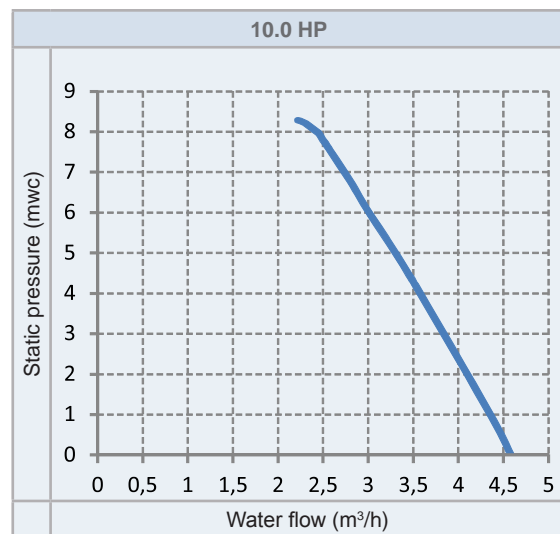
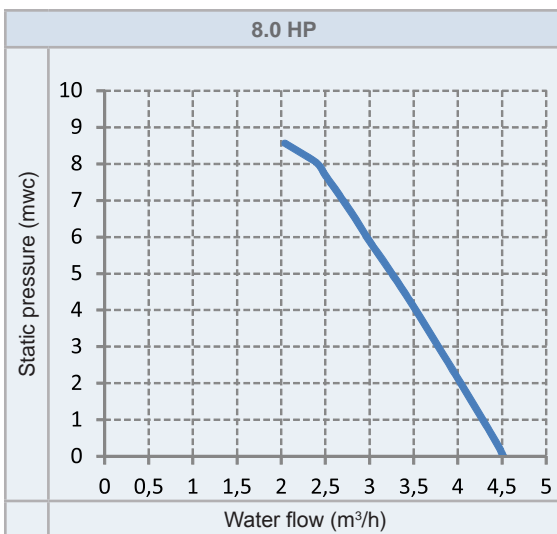
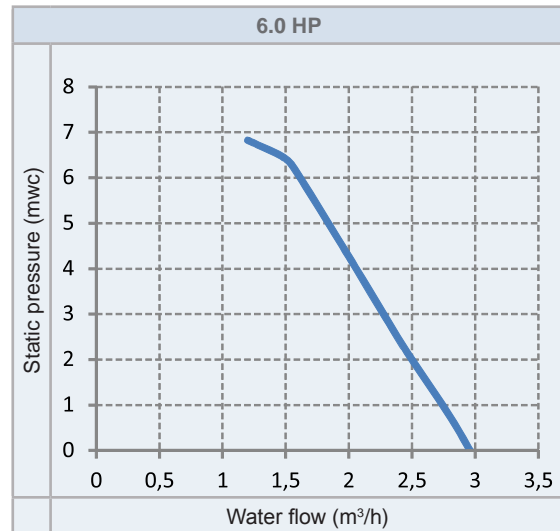
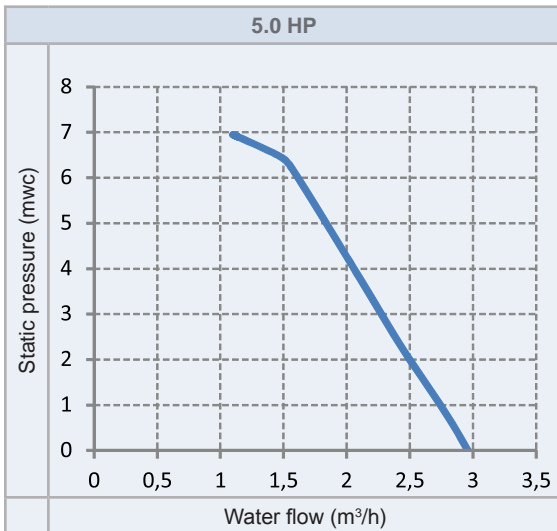

◆ YUTAKI S COMBI

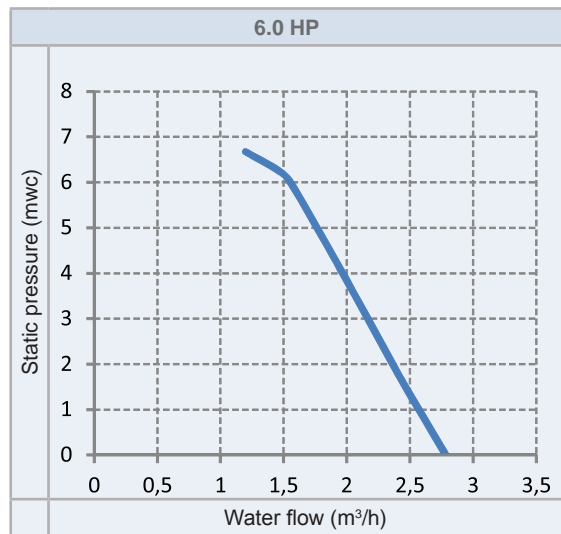
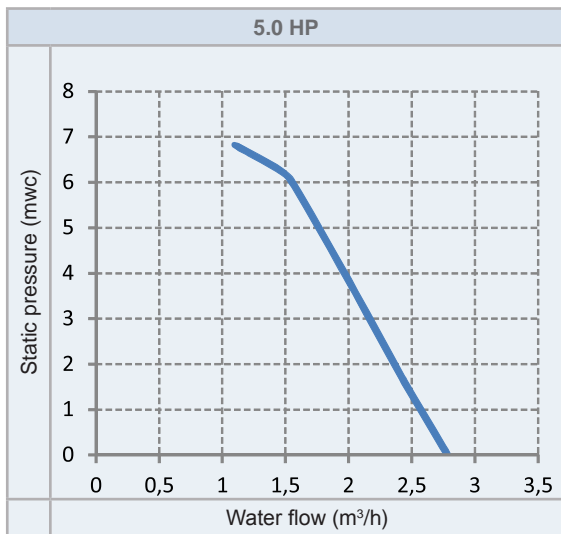
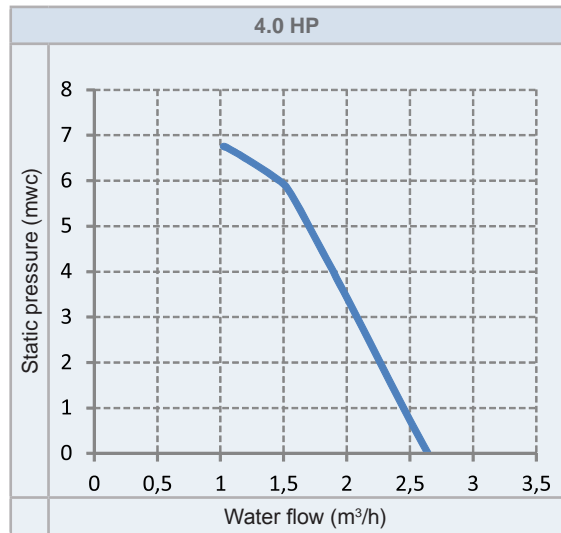
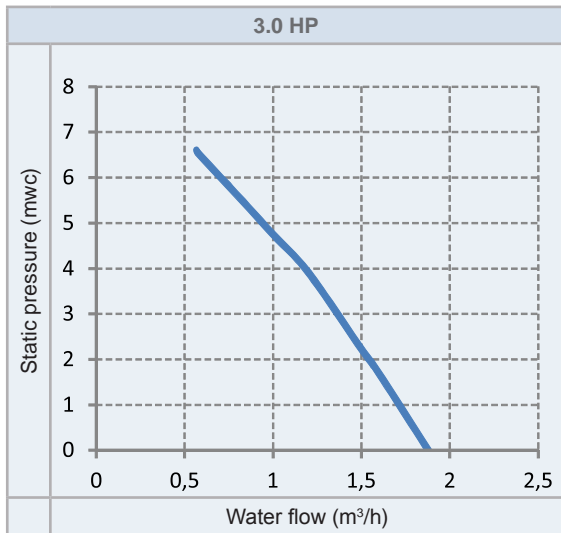
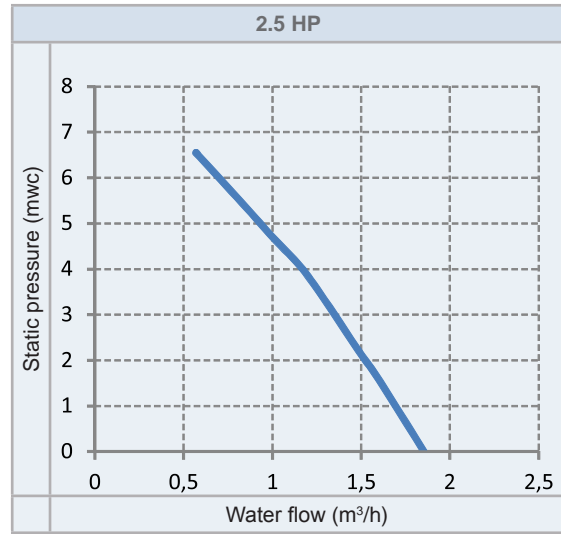
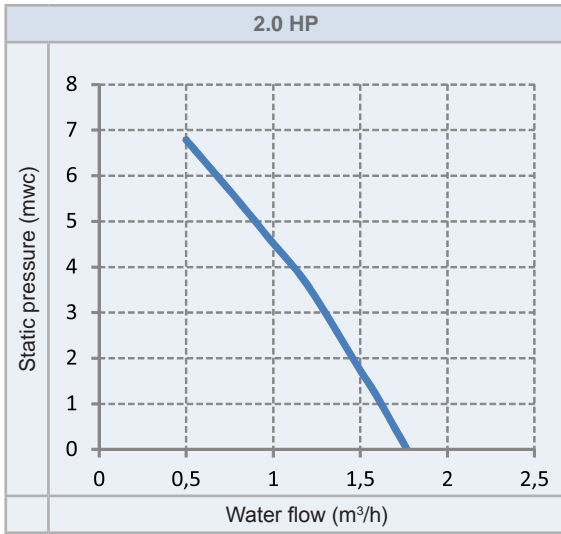

◆ YUTAKI S80

Version for indoor unit alone

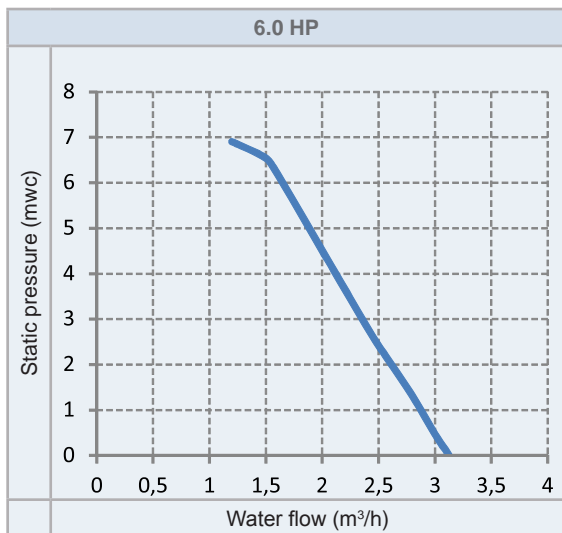
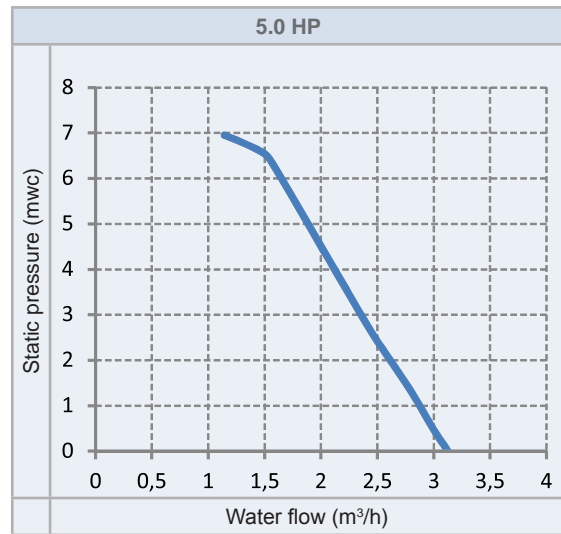
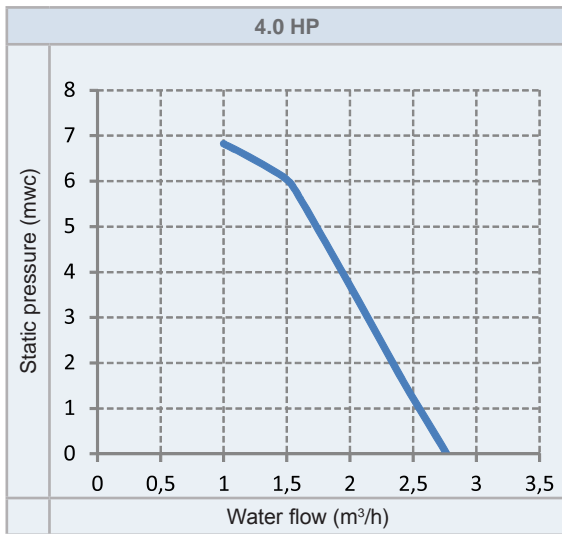

Version for combination with DHW tank

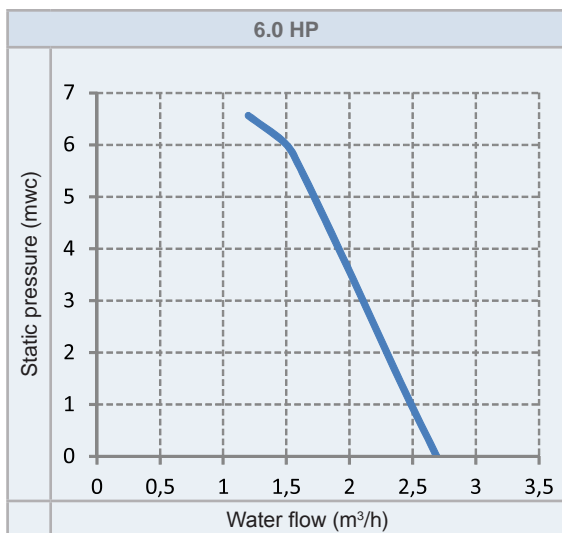
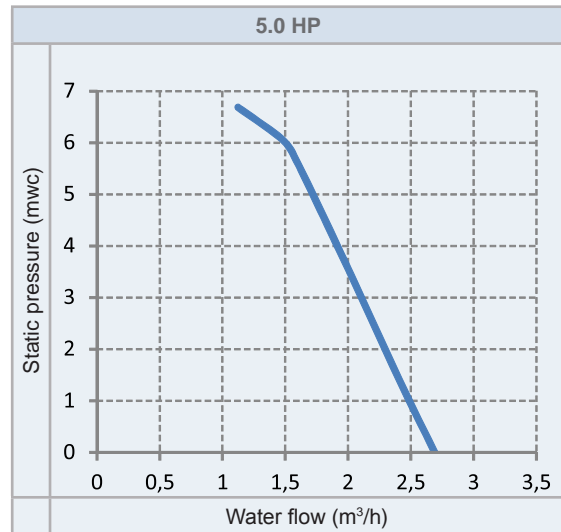
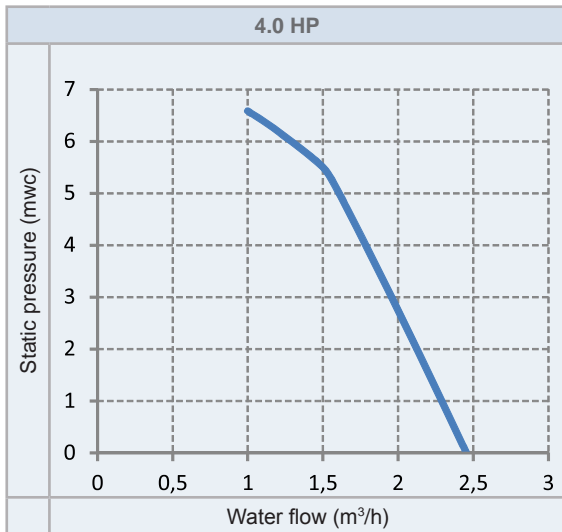

◆ YUTAKI M

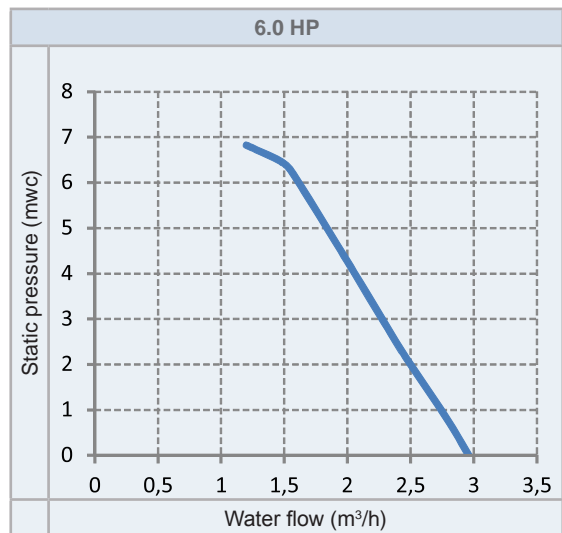
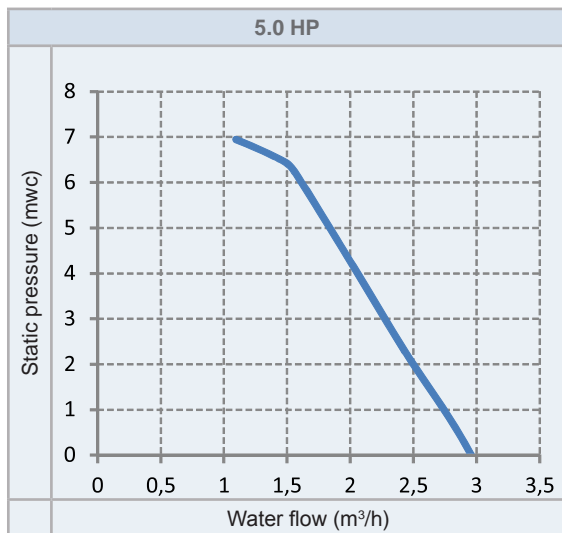
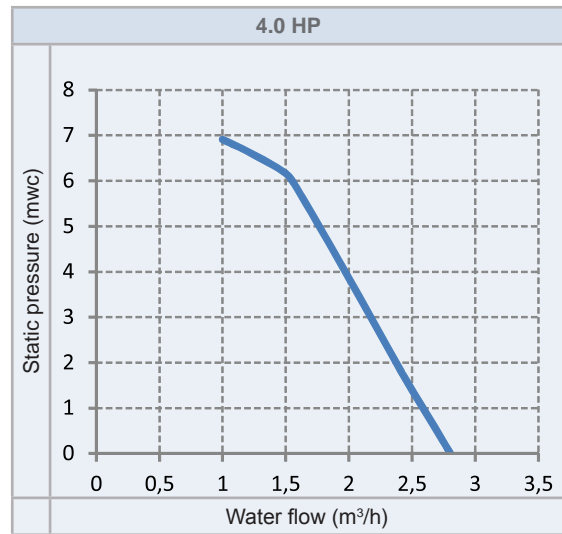
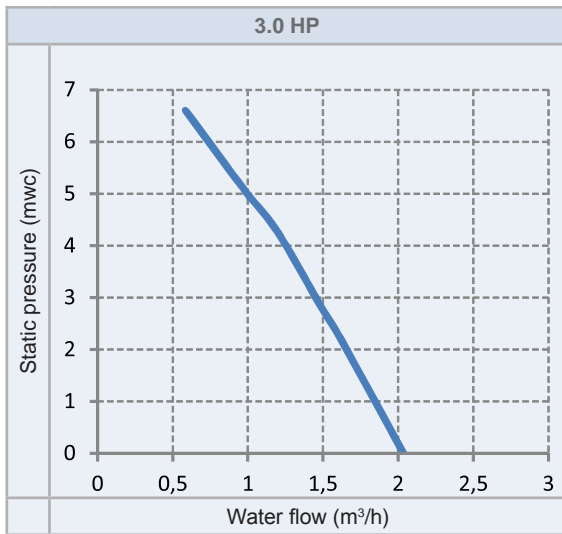

7 . General dimensions

Index

7.1	Name of parts and Dimensional data	170
7.1.1	Split system - Outdoor unit	170
7.1.2	Split system - Indoor unit	172
7.1.2.1	YUTAKI S	172
7.1.2.2	YUTAKI S COMBI	175
7.1.2.3	YUTAKI S80	180
7.1.3	Monobloc system - YUTAKI M	183
7.2	Service space	185
7.2.1	Split system - Outdoor unit	185
7.2.2	Split system - Indoor unit	186
7.2.2.1	YUTAKI S	186
7.2.2.2	YUTAKI S COMBI	186
7.2.3	Monobloc system - YUTAKI M	190

7.1 Name of parts and Dimensional data

7.1.1 Split system - Outdoor unit

◆ RAS-(2-3)WHVNP

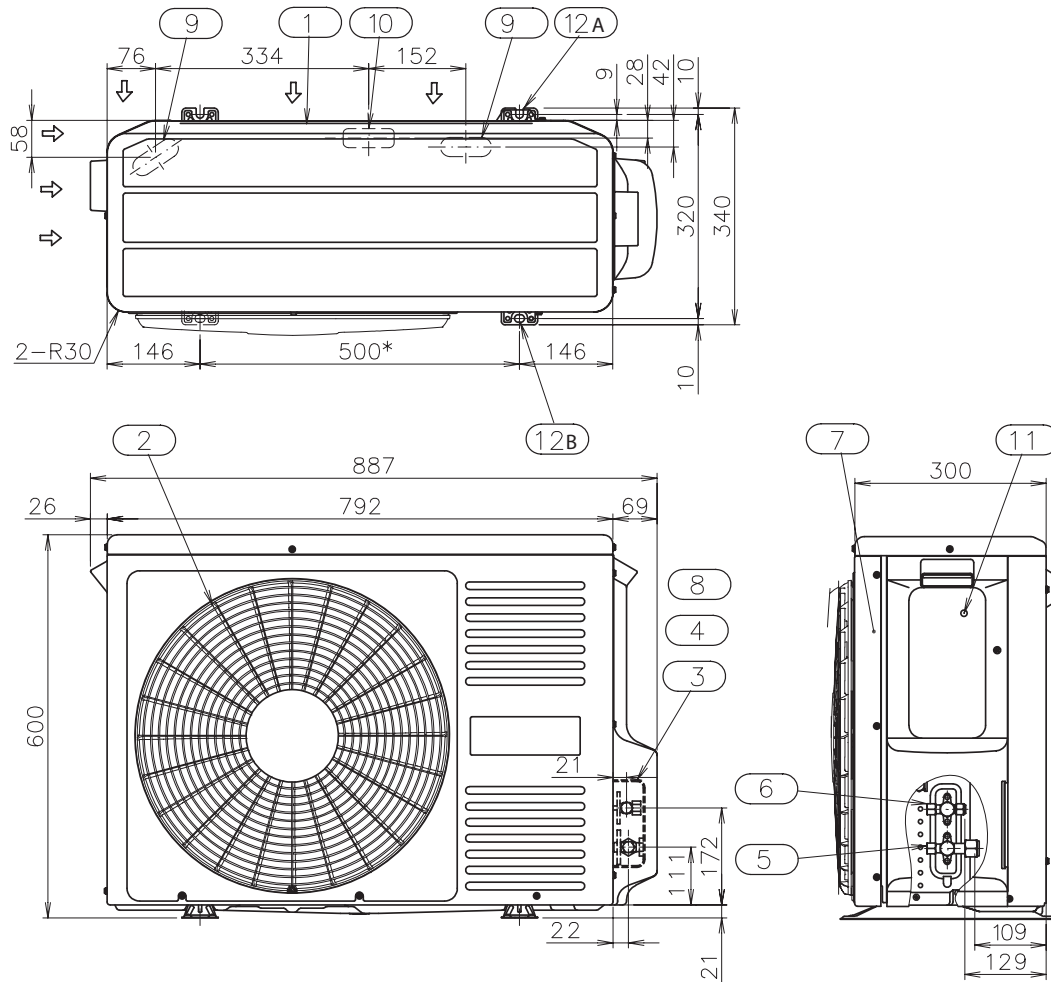

Units: mm

Number	Description	Remarks
1	Air inlet	—
2	Air outlet	—
3	Holes for power supply wiring	—
4	Holes for control line wiring	—
5	Gas piping connection	—
6	Liquid piping connection	—
7	Service panel	—
8	Refrigerant piping hole	—
9	Drain hole	—
10	Drain hole	—
11	Earth terminal wiring	(M5)
12	Holes for fixing machine to wall	A: 2-U cut holes / B: 2 - holes

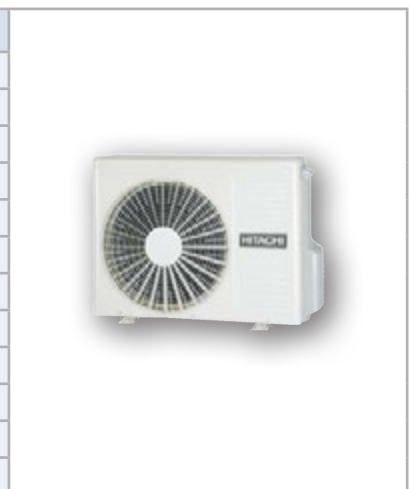

◆ RAS-(4-6)WH(V)NPE/ RAS-(8/10)WHNPE

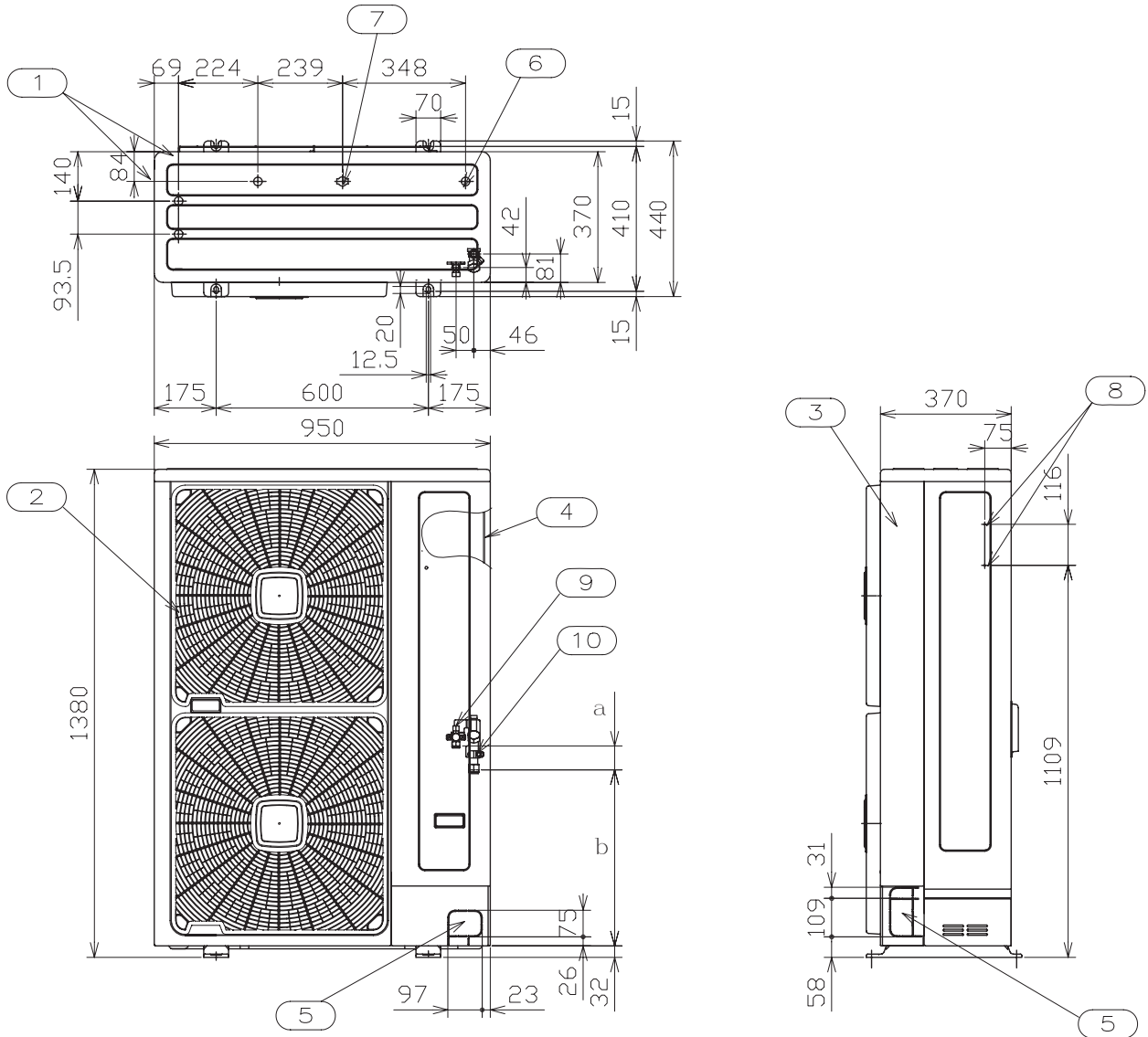

Units in: mm

Number	Description	Remarks
1	Air inlet	—
2	Air outlet	—
3	Service cover	—
4	Electrical switch box	—
5	Holes for refrigerant piping and electrical wiring piping	—
6	Drain holes	3-Ø24
7	Drain holes	2-Ø26
8	Holes for fixing machine to wall	4-(M5)
9	Refrigerant liquid pipe	—
10	Refrigerant gas pipe	—



	4-6 HP	8 HP	10 HP
a	90	81	99
b	459	465	465



7.1.2 Split system - Indoor unit

7.1.2.1 YUTAKI S

◆ RWM-(2.0-3.0)NE

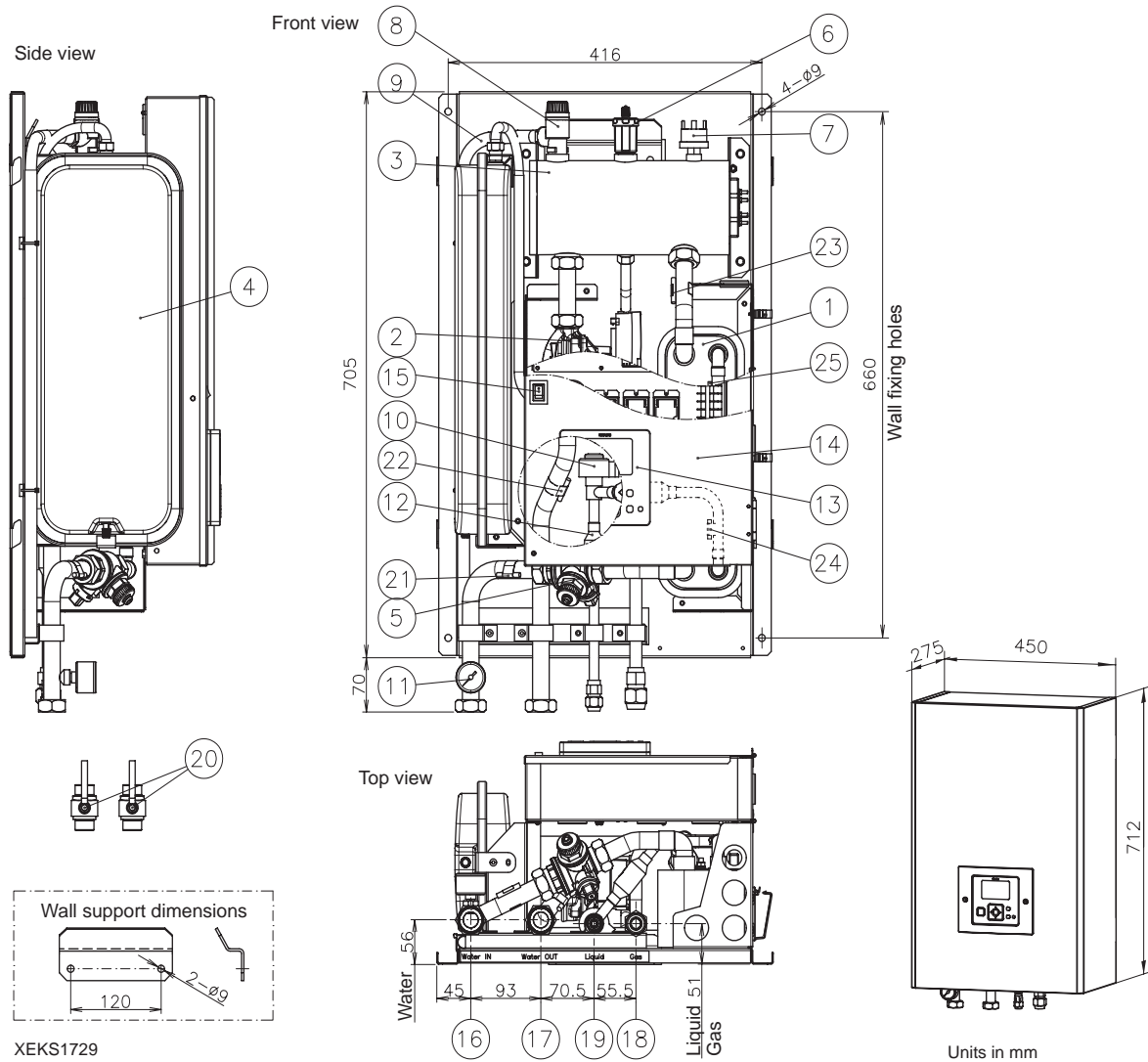

XEKS1729

Numb.	Part name	Numb.	Part name
1	Plate heat exchanger	13	Unit controller
2	Water pump	14	Electrical box
3	Electric water heater	15	Switch for DHW emergency operation
4	Expansion vessel 6L	16	Water inlet pipe connection - G 1" Female
5	Water strainer	17	Water outlet pipe connection - G 1" Female
6	Air purger	18	Refrigerant gas pipe connection - Ø15.88 (5/8")
7	Water low pressure switch	19	Refrigerant liquid pipe connection 2.0HP: Ø6.35 (1/4") 2.5/3.0HP: Ø9.52 (3/8")
8	Safety valve	20	Shut-off valve (Factory-supplied accessory)
9	Drain pipe for safety valve	21	Thermistor (Water inlet pipe)
10	Expansion valve	22	Thermistor (Water outlet pipe)
11	Manometer	23	Thermistor (Water outlet PHEX)
12	Refrigerant strainer (x2)	24	Thermistor (Liquid refrigerant pipe)
		25	Thermistor (Gas refrigerant pipe)



◆ RWM-(4.0-6.0)NE

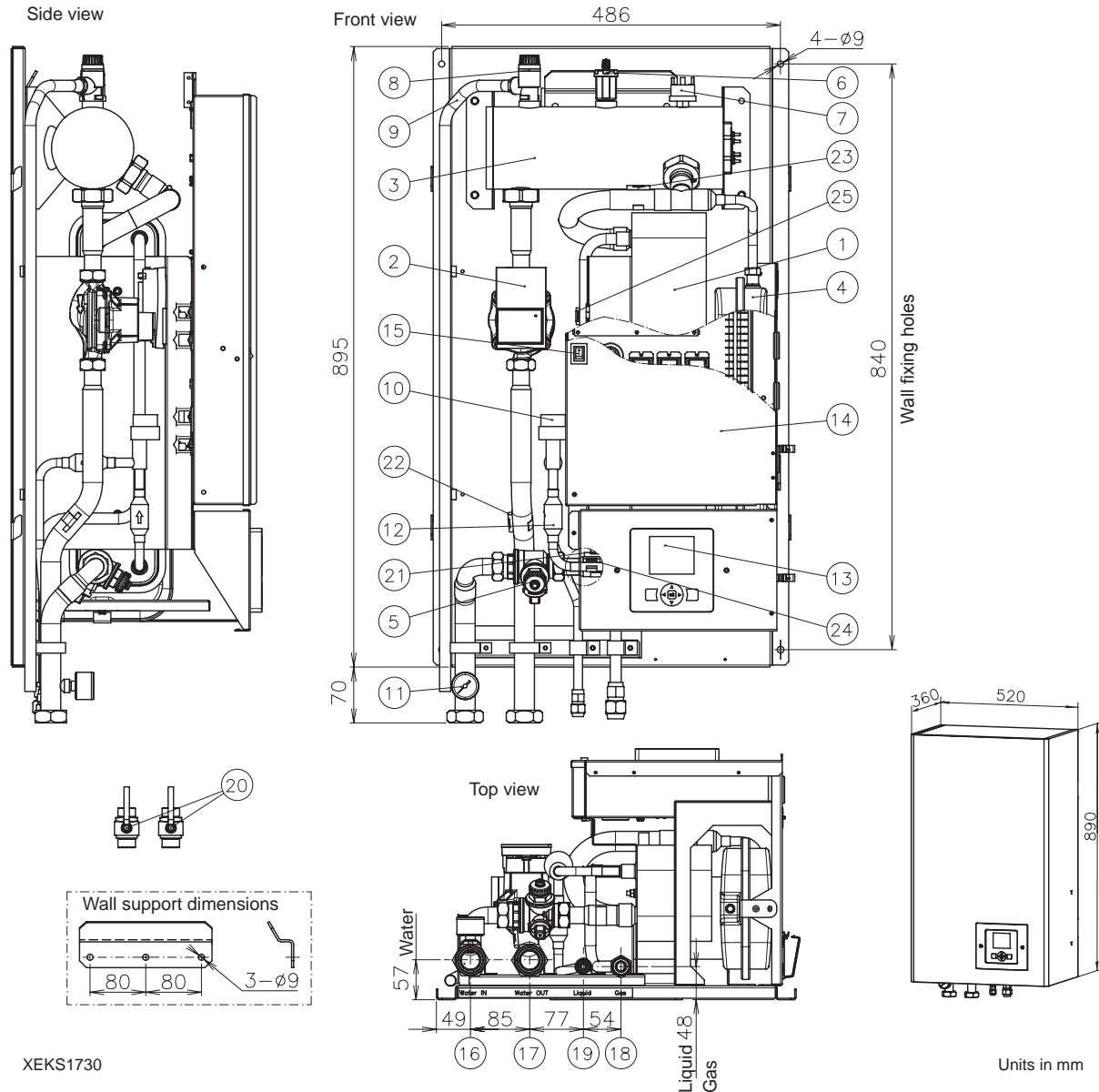

XEKS1730

Units in mm

Number	Part name	Number	Part name
1	Plate heat exchanger	13	Unit controller
2	Water pump	14	Electrical box
3	Electric water heater	15	Switch for DHW emergency operation
4	Expansion vessel 6L	16	Water inlet pipe connection - G 1 1/4" female
5	Water strainer	17	Water outlet pipe connection - G 1 1/4" female
6	Air purger	18	Refrigerant gas pipe connection - \varnothing 15.88 (5/8")
7	Water low pressure switch	19	Refrigerant liquid pipe - \varnothing 9.52 (3/8")
8	Safety valve	20	Shut-off valve (Factory supplied accessory)
9	Drain pipe for safety valve	21	Thermistor (Water inlet pipe)
10	Expansion valve (x2)	22	Thermistor (Water outlet pipe)
11	Manometer	23	Thermistor (Water outlet PHEX)
12	Refrigerant strainer	24	Thermistor (Liquid refrigerant pipe)
		25	Thermistor (Gas refrigerant pipe)



◆ RWM-(8.0/10.0)NE

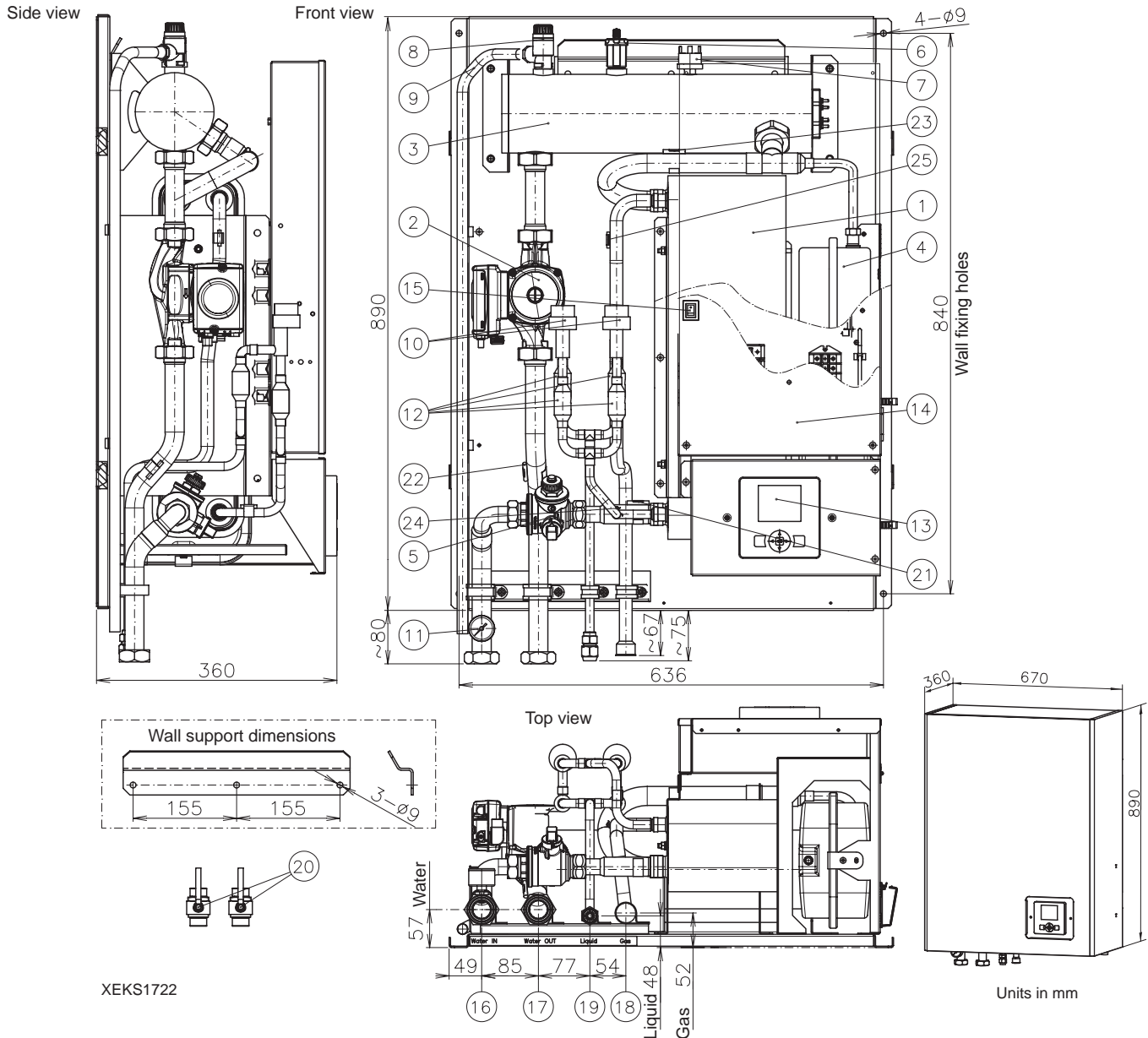

XEKS1722

Number	Part name	Number	Part name
1	Plate heat exchanger	13	Unit controller
2	Water pump	14	Electrical box
3	Electric water heater	15	Switch for DHW emergency operation
4	Expansion vessel 10L	16	Water inlet pipe connection - G 1 1/4" Female
5	Water strainer	17	Water outlet pipe connection - G 1 1/4" Female
6	Air purger	18	Refrigerant gas pipe connection - Ø25.4 (1")
7	Water low pressure switch	19	Refrigerant liquid pipe connection 8HP: Ø9.52 (3/8") 10HP: Ø12.7 (1/2")
8	Safety valve	20	Shut-off valve (factory-supplied accessory)
9	Drain pipe for safety valve	21	Thermistor (Water inlet pipe)
10	Expansion valve (x2)	22	Thermistor (Water outlet pipe)
11	Manometer	23	Thermistor (Water outlet PHEX)
12	Refrigerant strainer (x4)	24	Thermistor (Liquid refrigerant pipe)
		25	Thermistor (Gas refrigerant pipe)



7.1.2.2 YUTAKI S COMBI

◆ Standard model

RWD-(2.0-6.0)NWE-200S

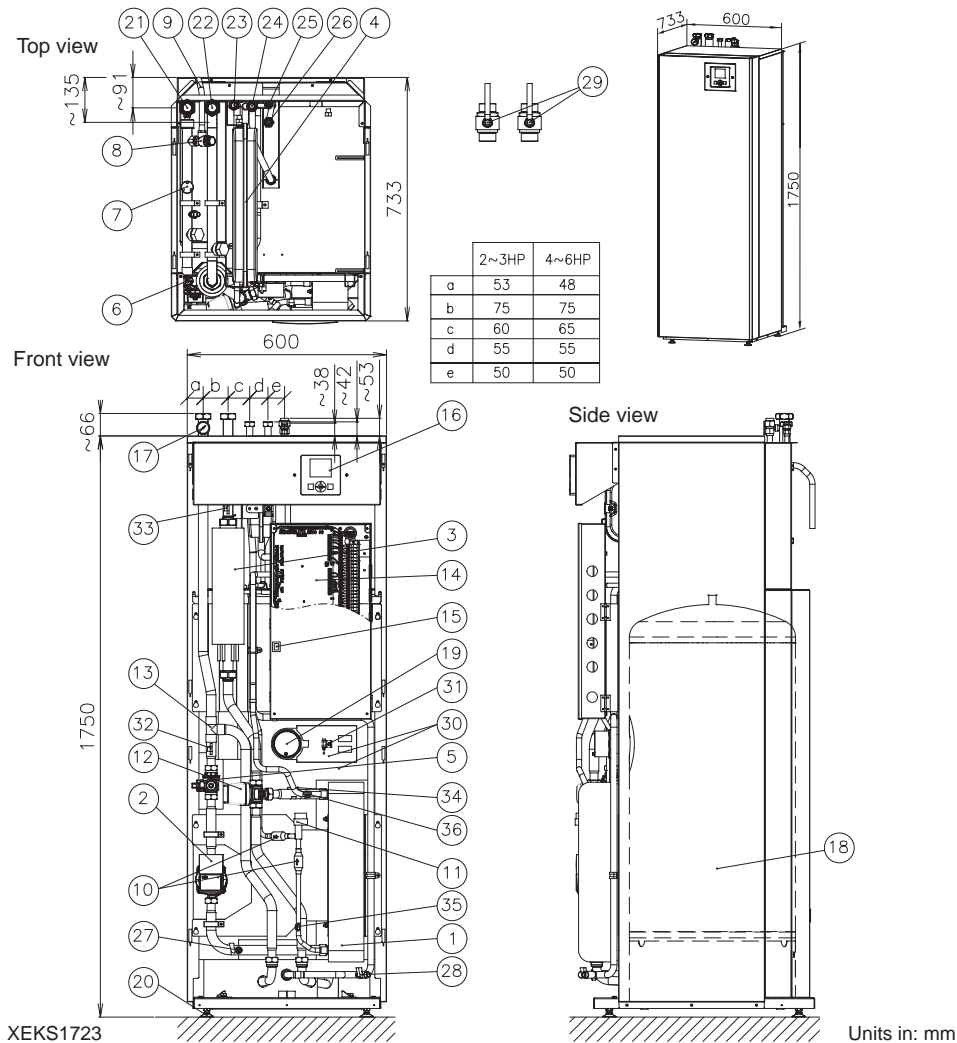

Number	Part name	Number	Part name
1	Plate heat exchanger	19	DHW tank heater+thermostat
2	Water pump	20	Mounting foot (x4)
3	Electric water heater	21	Water inlet connection 2.0-3.0HP: G 1" female / 4.0-6.0HP: G1 1/4" female
4	Expansion vessel 6L	22	Water outlet connection 2.0-3.0HP: G 1" female / 4.0-6.0HP: G1 1/4" female
5	Water strainer	23	DHW inlet connection - G 3/4" female
6	Air purger	24	DHW outlet connection - G 3/4" female
7	Low water pressure switch	25	Refrigerant liquid connection 2.0HP: \varnothing 6.35 (1/4") / 2.5-6HP: \varnothing 9.52 (3/8")
8	Safety valve	26	Refrigerant gas connection - \varnothing 15.88 (G 3/8")
9	Drain pipe for safety valve	27	Drain port (For indoor unit water) - G 3/8"
10	Refrigerant strainer (x2)	28	Drain port (For DHW) - G 3/8"
11	Expansion valve	29	Shut-off valve (Factory supplied accessory)
12	3-way valve (for space heating and DHW)	30	Tank insulation
13	T-branch (for space heating and DHW)	31	DHW thermistor
14	Electrical box	32	Water inlet thermistor
15	Switch for DHW emergency operation	33	Water outlet thermistor
16	Unit controller	34	Water outlet PHEX thermistor
17	Manometer	35	Refrigerant liquid pipe thermistor
18	DHW tank (200L)	36	Refrigerant gas pipe thermistor



RWD-(2.0-6.0)NWE-260S

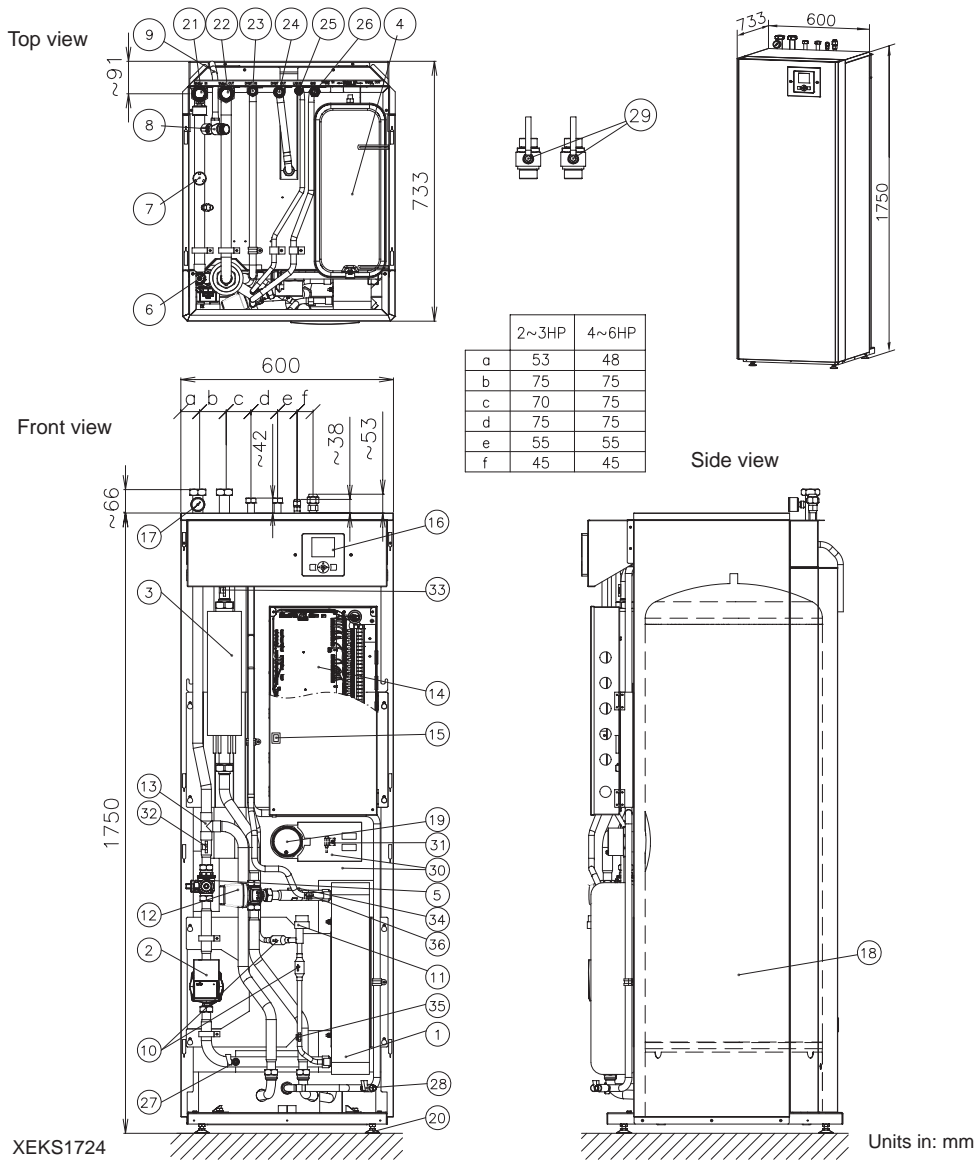

Number	Part name	Number	Part name
1	Plate heat exchanger	19	DHW tank heater+thermostat
2	Water pump	20	Mounting foot (x4)
3	Electric water heater	21	Water inlet connection 2.0-3.0HP: G 1" female / 4.0-6.0HP: G1 1/4" female
4	Expansion vessel 6L	22	Water outlet connection 2.0-3.0HP: G 1" female / 4.0-6.0HP: G1 1/4" female
5	Water strainer	23	DHW inlet connection - G 3/4" female
6	Air purger	24	DHW outlet connection - G 3/4" female
7	Low water pressure switch	25	Refrigerant liquid connection 2HP: \varnothing 6.35 (1/4")/2.5~6HP: \varnothing 9.52 (3/8")
8	Safety valve	26	Refrigerant gas connection - \varnothing 15.88 (G 3/8")
9	Drain pipe for safety valve	27	Drain port (For indoor unit water) - G 3/8"
10	Refrigerant strainer	28	Drain port (For DHW) - G 3/8"
11	Expansion valve	29	Shut-off valve (Factory supplied accessory)
12	3-way valve (for space heating and DHW)	30	Tank insulation
13	T-branch (for space heating and DHW)	31	DHW thermistor
14	Electrical box	32	Water inlet thermistor
15	Switch for DHW emergency operation	33	Water outlet thermistor
16	Unit controller	34	Water outlet PHEX thermistor
17	Manometer	35	Refrigerant liquid pipe thermistor
18	DHW tank (260L)	36	Refrigerant gas pipe thermistor



◆ Model for solar combination

RWD-(2.0-6.0)NWSE-260S

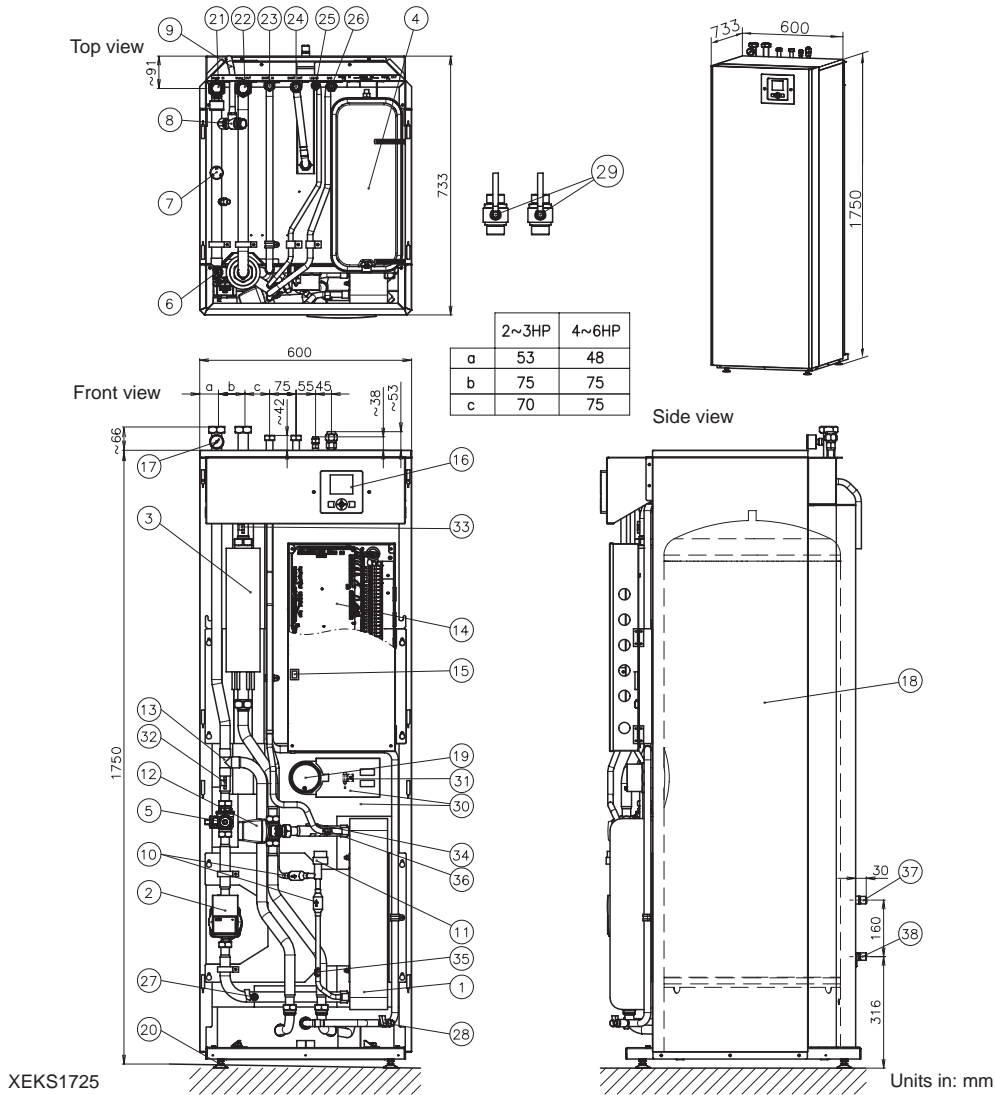

Number	Part name	Number	Part name
1	Plate heat exchanger	20	Mounting foot (x4)
2	Water pump	21	Water inlet connection 2.0-3.0HP: G 1" female / 4.0-6.0HP: G1 1/4" female
3	Electric water heater	22	Water outlet connection 2.0-3.0HP: G 1" female / 4.0-6.0HP: G1 1/4" female
4	Expansion vessel 6L	23	DHW inlet connection - G 1/4" female
5	Water strainer	24	DHW outlet connection - G 1/4" female
6	Air purger	25	Refrigerant liquid connection 2.0HP: $\varnothing 6.35(1/4)$ -2.5~6.0HP: $\varnothing 9.52(1/4)$
7	Low water pressure switch	26	Refrigerant gas connection $\varnothing 15.88(5/8)$
8	Safety valve	27	Drain port (for indoor unit water)- G3/8"
9	Drain pipe for safety valve	28	Drain port (for DHW)- G3/8"
10	Refrigerant strainer (x2)	29	Shut-off valve (Factory supplied)
11	Expansion valve	30	Tank insulation
12	3-way valve (for space heating and DHW)	31	DHW thermistor
13	T-branch (for space heating and DHW)	32	Water inlet thermistor
14	Electrical box	33	Water outlet thermistor
15	Switch for DHW "emergency" operation	34	Water outlet PHEX thermistor
16	Unit controller	35	Refrigerant liquid pipe thermistor
17	Manometer	36	Refrigerant gas pipe thermistor
18	DHW tank (260L)	37	Solar coil inlet connection
19	DHW tank heater + thermostat	38	Solar coil outlet connection



◆ Model for UK market

RWD-(2.0-6.0)NWSE-200S-K

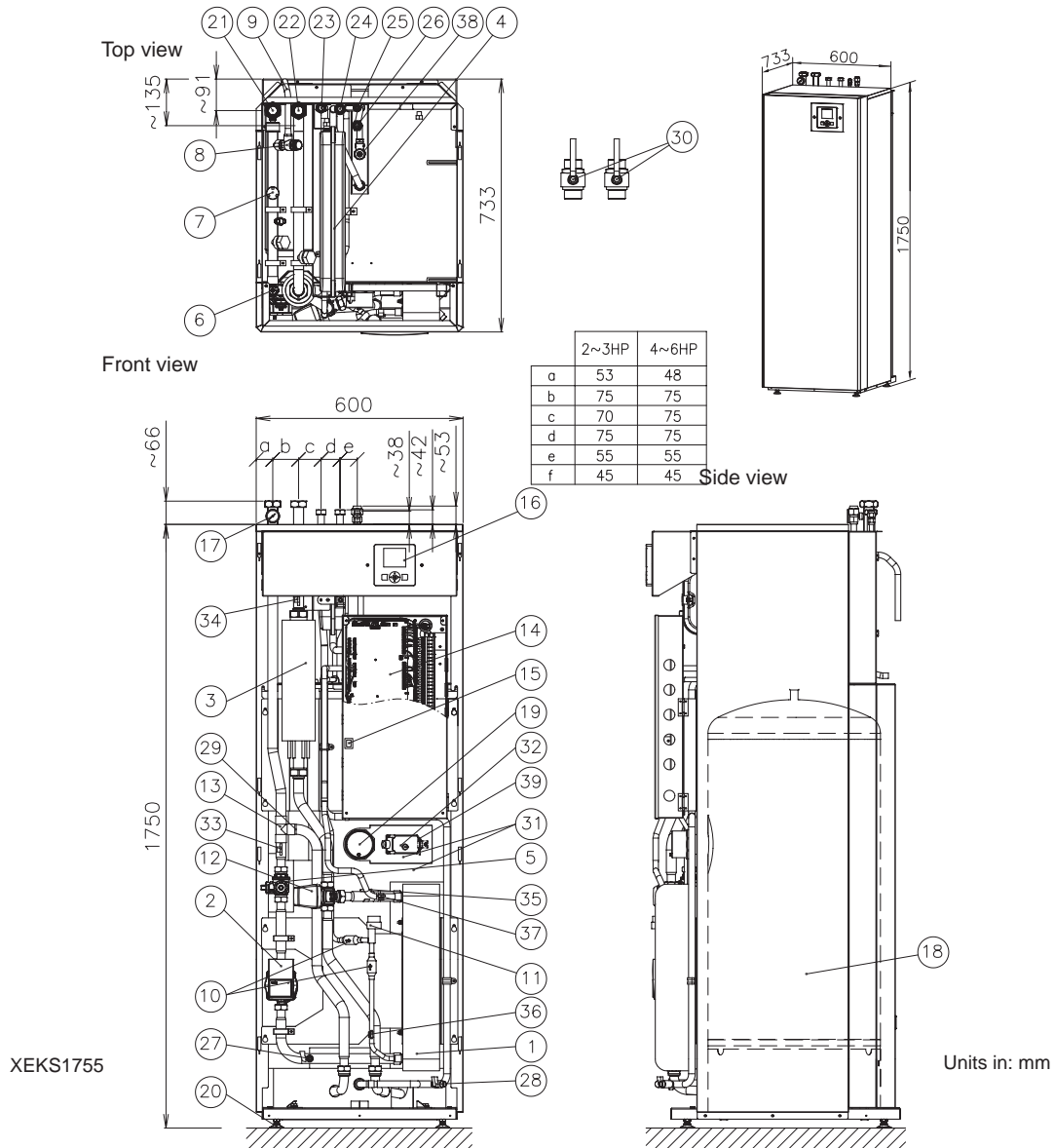

Number	Part name	Number	Part name
1	Plate heat exchanger	21	Water inlet connection 2.0-3.0HP: G 1" female / 4.0-6.0HP: G1 1/4" female
2	Water pump	22	Water outlet connection 2.0-3.0HP: G 1" female / 4.0-6.0HP: G1 1/4" female
3	Electric water heater	23	DHW inlet connection - G 3/4" female
4	Expansion vessel 6L	24	DHW outlet connection - G 3/4" female
5	Water strainer	25	Refrigerant liquid connection 2.0HP: \varnothing 6.35 (1/4") / 2.5-6HP: \varnothing 9.52 (3/8")
6	Air purger	26	Refrigerant gas connection - \varnothing 15.88 (G 3/8")
7	Low water pressure switch	27	Drain port (For indoor unit water) - G 3/8"
8	Safety valve	28	Drain port (For DHW) - G 3/8"
9	Drain pipe for safety valve	29	Manual air purger
10	Refrigerant strainer (x2)	30	Shutdown valve (Factory supplied accessory)
11	Expansion valve	31	Tank insulation
12	3-way valve (for space heating and DHW)	32	DHW thermistor
13	T-branch (for space heating and DHW)	33	Water inlet thermistor
14	Electrical box	34	Water outlet thermistor
15	Switch for DHW emergency operation	35	Water outlet PHEX thermistor
16	Unit controller	36	Refrigerant liquid pipe thermistor
17	Manometer	37	Refrigerant gas pipe thermistor
18	DHW tank (200L)	38	Pressure and Temperature relief valve
19	DHW tank heater+thermostat	39	DHWT Thermostat
20	Mounting foot (x4)		



RWD-(2.0-6.0)NWSE-260S-K

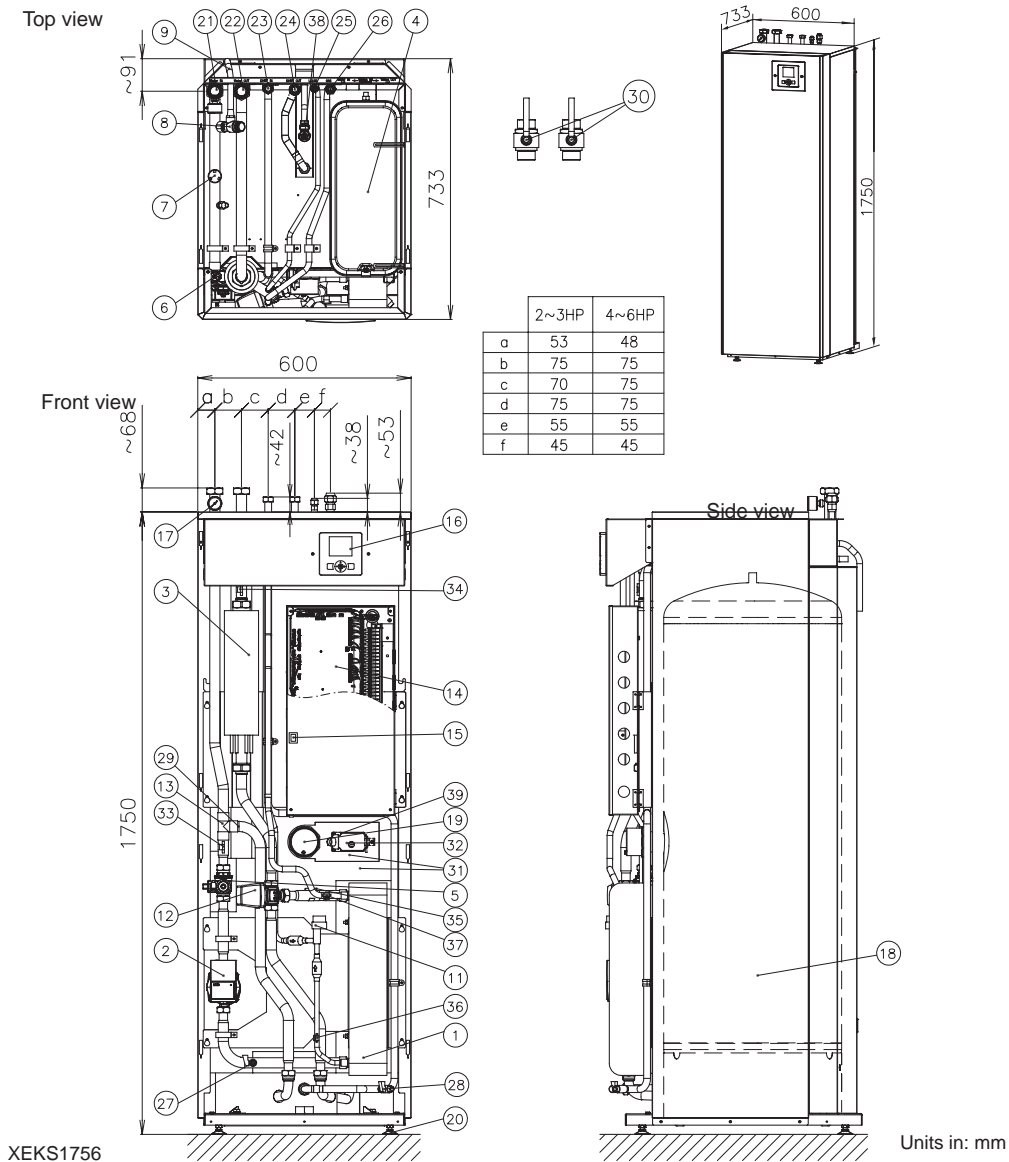

Number	Part name	Number	Part name
1	Plate heat exchanger	21	Water inlet connection 2.0-3.0HP: G 1" female / 4.0-6.0HP: G1 1/4" female
2	Water pump	22	Water outlet connection 2.0-3.0HP: G 1" female / 4.0-6.0HP: G1 1/4" female
3	Electric water heater	23	DHW inlet connection - G 3/4" female
4	Expansion vessel 6L	24	DHW outlet connection - G 3/4" female
5	Water strainer	25	Refrigerant liquid connection 2HP: \varnothing 6.35 (1/4")/2.5-6HP: \varnothing 9.52 (3/8")
6	Air purger		
7	Low water pressure switch	26	Refrigerant gas connection - \varnothing 15.88 (G 3/8")
8	Safety valve	27	Drain port (For indoor unit water) - G 3/8"
9	Drain pipe for safety valve	28	Drain port (For DHW) - G 3/8"
10	Refrigerant strainer	29	Manual air purger
11	Expansion valve	30	Shutdown valve (Factory supplied accessory)
12	3-way valve (for space heating and DHW)	31	Tank insulation
13	T-branch (for space heating and DHW)	32	DHW thermistor
14	Electrical box	33	Water inlet thermistor
15	Switch for DHW emergency operation	34	Water outlet thermistor
16	Unit controller	35	Water outlet PHEX thermistor
17	Manometer	36	Refrigerant liquid pipe thermistor
18	DHW tank (260L)	37	Refrigerant gas pipe thermistor
19	DHW tank heater+thermostat	38	Pressure and Temperature relief valve
20	Mounting foot (x4)	39	DHWT Thermostat



7.1.2.3 YUTAKI S80

◆ TYPE 1: Version for operation in DHW but with a remote tank

RWH-(4.0-6.0)(V)NFE

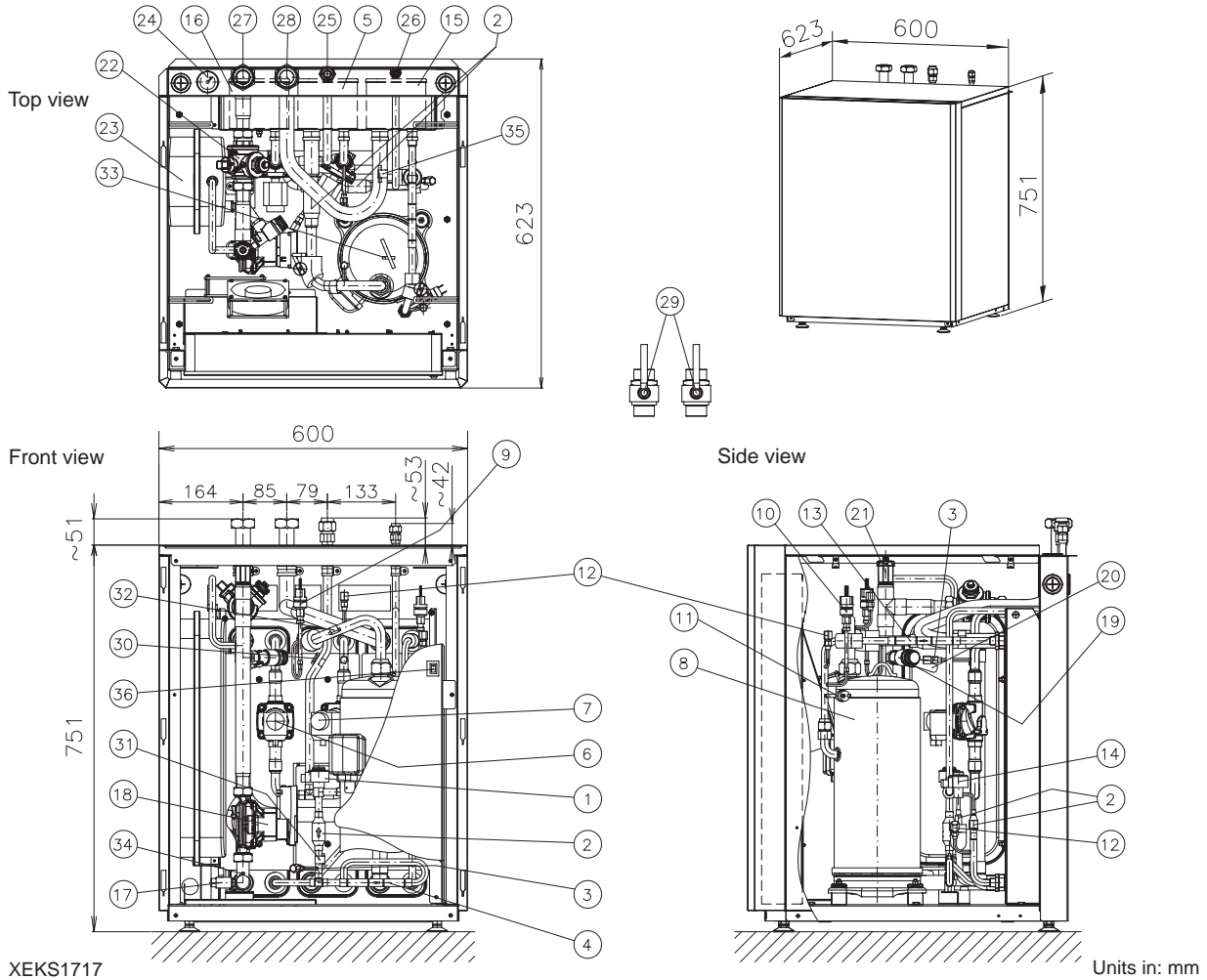

Number	Part name	Number	Part name
1	Electronic expansion valve (R410A)	19	Safety valve
2	Refrigerant strainer (x2)	20	Drain pipe
3	Check joint (R410A)	21	Air purger
4	Check valve (R410A)	22	Water strainer
5	Plate heat exchanger (R410A-R134a)	23	Expansion vessel 12L
6	Solenoid valve (1 cycle)	24	Manometer
7	Solenoid valve (2 cycles)	25	Refrigerant gas pipe - $\varnothing 15.88$ (5/8")
8	Compressor	26	Refrigerant liquid pipe - $\varnothing 9.52$ (3/8")
9	Low pressure sensor (Ps)	27	Water inlet pipe - G 1 1/4" female
10	High pressure sensor (Pd)	28	Water outlet pipe - G 1 1/4" female
11	High pressure switch (PSH)	29	Shut-off valve (Factory supplied)
12	Check joint (R134a)	30	Refrigerant gas pipe thermistor
13	Check valve (R134a)	31	Refrigerant liquid pipe thermistor
14	Electronic expansion valve (R134a)	32	Compressor suction thermistor
15	Plate heat exchanger (R134a-H2O)	33	Compressor discharge thermistor
16	Plate heat exchanger (R410A-H2O)	34	Water inlet thermistor
17	Water pressure port	35	Water outlet thermistor
18	Water pump	36	Switch for DHW "emergency" operation



◆ TYPE 2: Version for operation with HITACHI DHW tank

RWH-(4.0-6.0)(V)NFWE

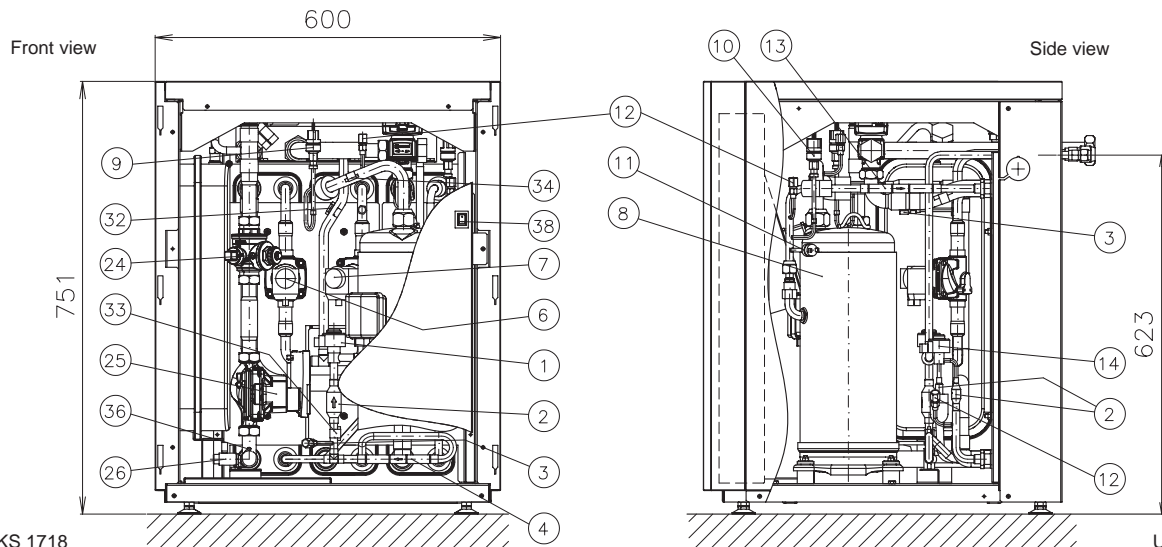
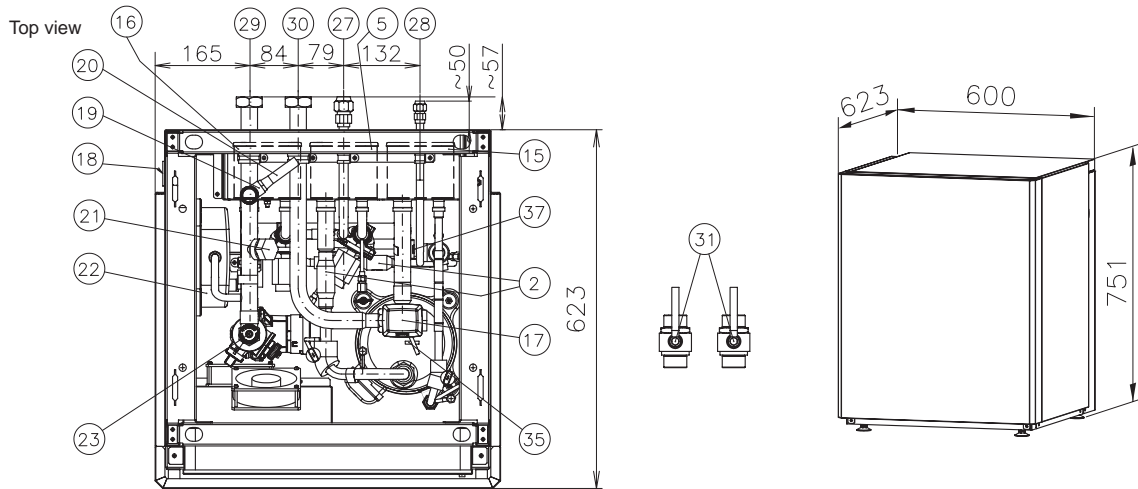

XEKS 1718

Units in: mm

Number	Part name	Number	Part name
1	Electronic expansion valve (R410A)	20	Drain pipe
2	Refrigerant strainer (x2)	21	Connection for DHW tank outlet
3	Check joint (R410A)	22	Expansion vessel 12L
4	Check valve (R410A)	23	Air purger
5	Plate heat exchanger (R410A-R134a)	24	Water strainer
6	Solenoid valve (1 cycle)	25	Water pump
7	Solenoid valve (2 cycles)	26	Drain port
8	Compressor	27	Refrigerant gas pipe - Ø15.88 (5/8")
9	Low pressure sensor (Ps)	28	Refrigerant liquid pipe - Ø9.52 (3/8")
10	High pressure sensor (Pd)	29	Water inlet pipe - G 1 1/4" female
11	High pressure switch (PSH)	30	Water outlet pipe - G 1 1/4" female
12	Check joint (R134a)	31	Shut-off valve (Factory supplied)
13	Check valve (R134a)	32	Refrigerant gas pipe thermistor
14	Electronic expansion valve (R134a)	33	Refrigerant liquid pipe thermistor
15	Plate heat exchanger (R134a-H2O)	34	Compressor suction thermistor
16	Plate heat exchanger (R410A-H2O)	35	Compressor discharge thermistor
17	3 way valve	36	Water inlet thermistor
18	Manometer	37	Water outlet thermistor
19	Safety valve	38	Switch for DHW "emergency" operation



◆ Domestic hot water tank

DHWS(200/260)S-2.0H2E

Front view

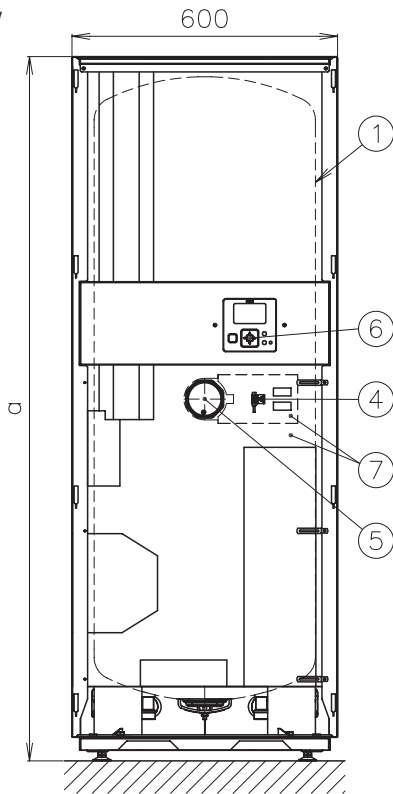

Rear view

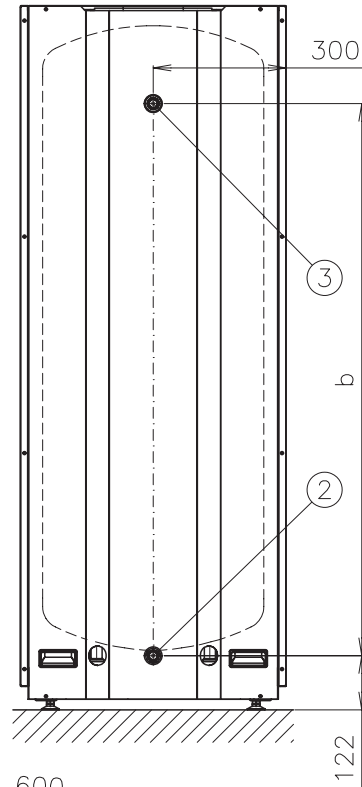

Top view

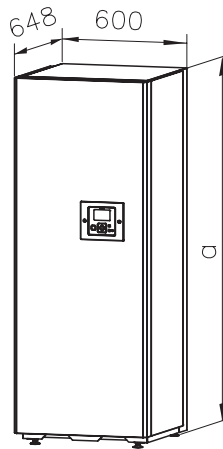
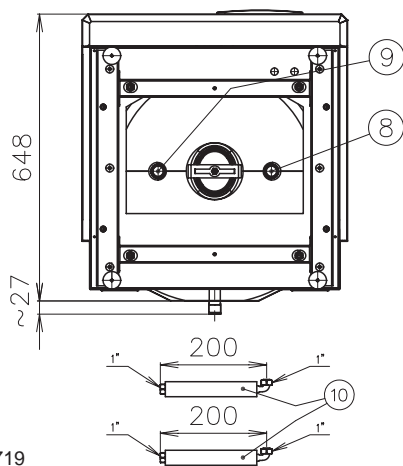

Dimensions according the unit

Unit/Dimension	a	b
DHWS200S-2.0H2E	1282	938.5
DHWS260S-2.0H2E	1591	1247.5

XEKS 1719

Units in mm.

Number	Part name
1	Domestic hot water tank
2	DHW inlet G 3/4" male
3	DHW outlet G 3/4" male
4	DHW tank thermistor
5	Heater+ thermostat
6	Unit Controller
7	Tank insulation
8	Heating coil inlet connection G 1" male
9	Heating coil outlet connection G 1" male
10	Flexible pipe (x2)



7.1.3 Monobloc system - YUTAKI M

RASM-3VNE

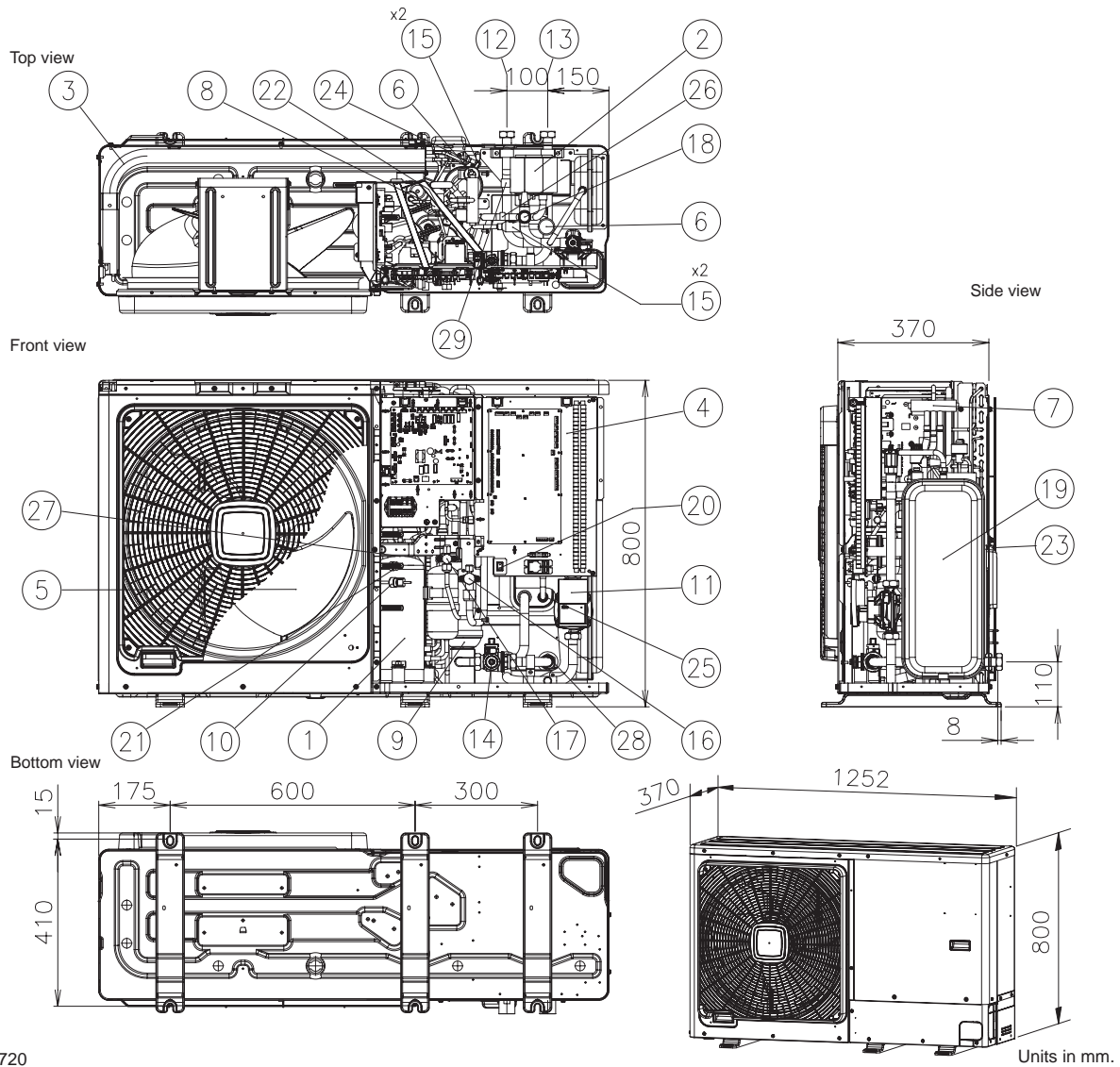

XEKS 1720

Units in mm.

Number	Part name	Number	Part name
1	Compressor	15	Refrigerant strainer (x4)
2	Water side heat exchanger	16	Stop valve for gas line - Ø15.88 (5/8")
3	Air side heat exchanger	17	Stop valve for liquid line - Ø9.52 (3/8")
4	Electrical box	18	Safety valve
5	Fan (x1)	19	Expansion vessel 6L
6	Expansion valve (x2)	20	Switch for DHW "emergency" operation
7	Reversing valve	21	Sensor for refrigerant pressure
8	Solenoid valve	22	Pressure switch for control (Pd)
9	Accumulator	23	Ambient thermistor
10	High pressure switch (PSH)	24	Evaporating temperature thermistor
11	Water pump	25	Refrigerant liquid pipe thermistor
12	Water outlet - G 1"	26	Refrigerant gas pipe thermistor
13	Water inlet - G 1"	27	Compressor discharge thermistor
14	Water strainer	28	Water inlet thermistor
		29	Water outlet thermistor



RASM-(4-6)(V)NE

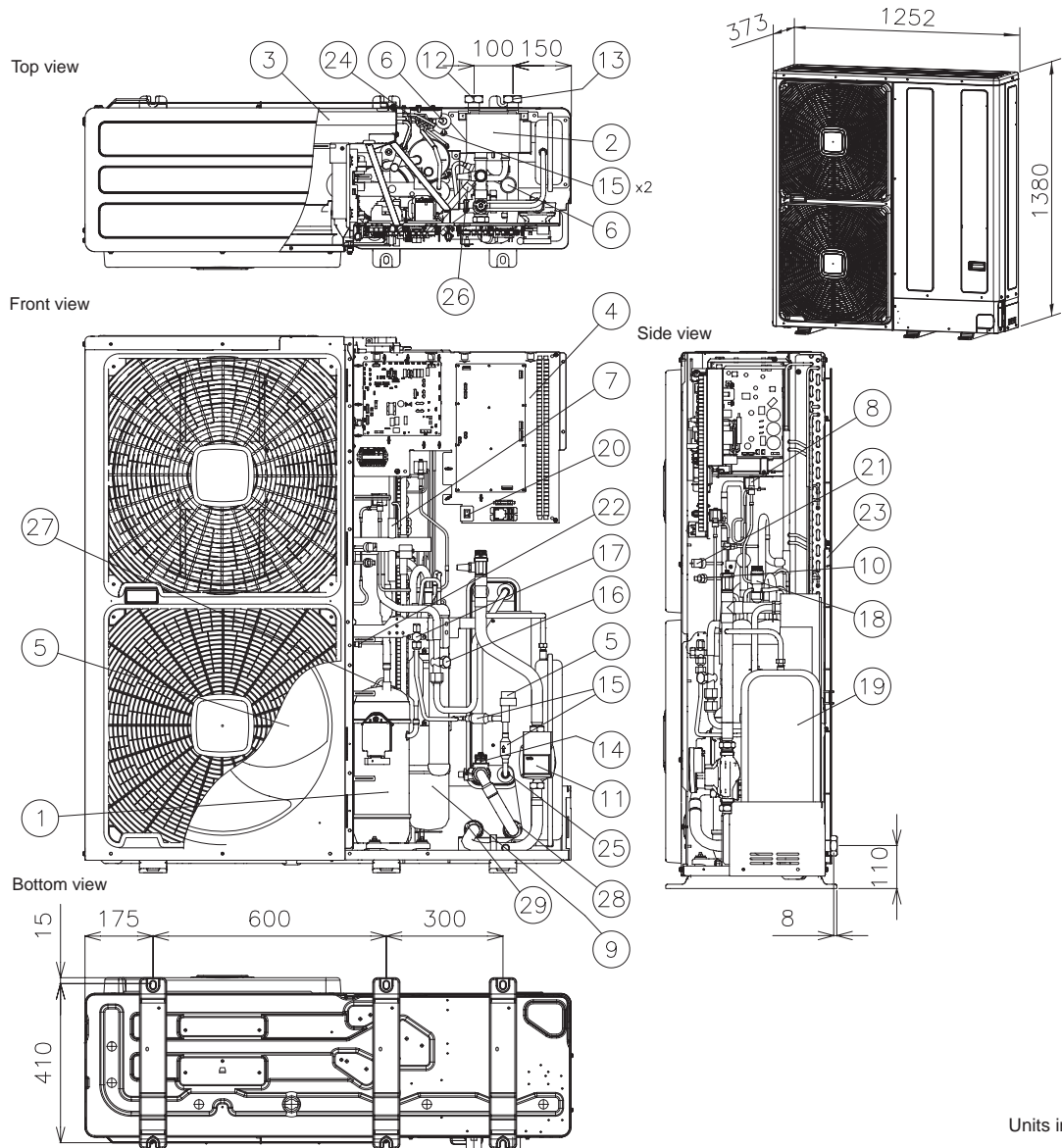

XEKS 1721

Units in mm.

Number	Part name	Number	Part name
1	Compressor	15	Refrigerant strainer (x4)
2	Water side heat exchanger	16	Stop valve for gas line - Ø25.4 (1")
3	Air side heat exchanger	17	Stop valve for liquid line - Ø9.52 (3/8")
4	Electrical box	18	Safety valve
5	Fan (x2)	19	Expansion vessel 6L
6	Expansion valve (x2)	20	Switch for DHW "emergency" operation
7	Reversing valve	21	Sensor for refrigerant pressure
8	Solenoid valve	22	Pressure switch for control (Pd)
9	Accumulator	23	Ambient thermistor
10	High pressure switch (PSH)	24	Evaporating temperature thermistor
11	Water pump	25	Refrigerant liquid pipe thermistor
12	Water outlet - G 1 1/4"	26	Refrigerant gas pipe thermistor
13	Water inlet - G 1 1/4"	27	Compressor discharge thermistor
14	Water strainer	28	Water inlet thermistor
		29	Water outlet thermistor



7.2 Service space

7.2.1 Split system - Outdoor unit

RAS-(2-3)WHVNP

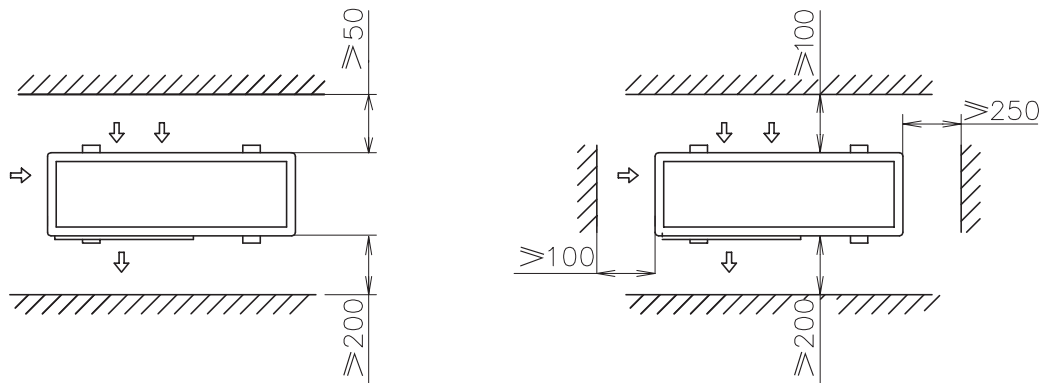

RAS-(4-6)WH(V)NPE/ RAS-(8/10)WHNPE

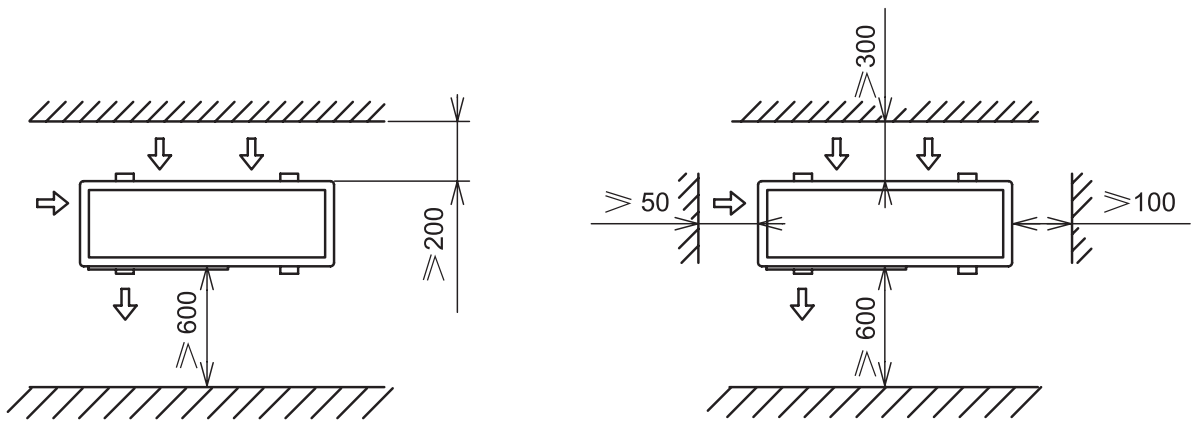

Units in mm.

i NOTE

Please refer to the Service Manual for detailed information.



7.2.2 Split system - Indoor unit

7.2.2.1 YUTAKI S

RWM-(2.0-10.0)NE

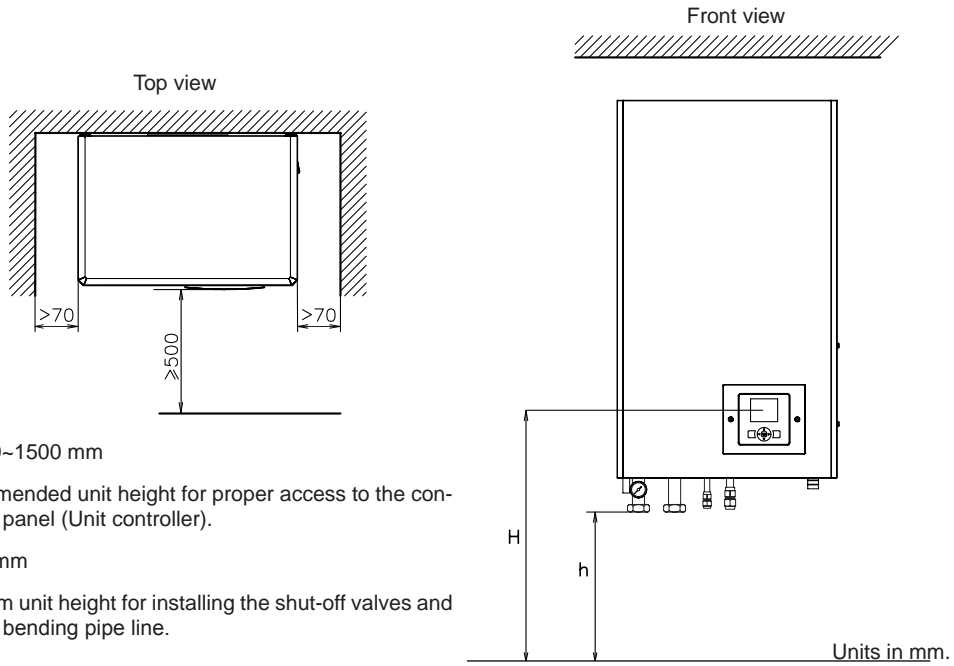

H: 1200~1500 mm

Recommended unit height for proper access to the control unit panel (Unit controller).

h: 350 mm

Minimum unit height for installing the shut-off valves and the first bending pipe line.

7.2.2.2 YUTAKI S COMBI

◆ Standard model and UK market

RWD-(2.0-6.0)NWE-(200/260)S(-K)

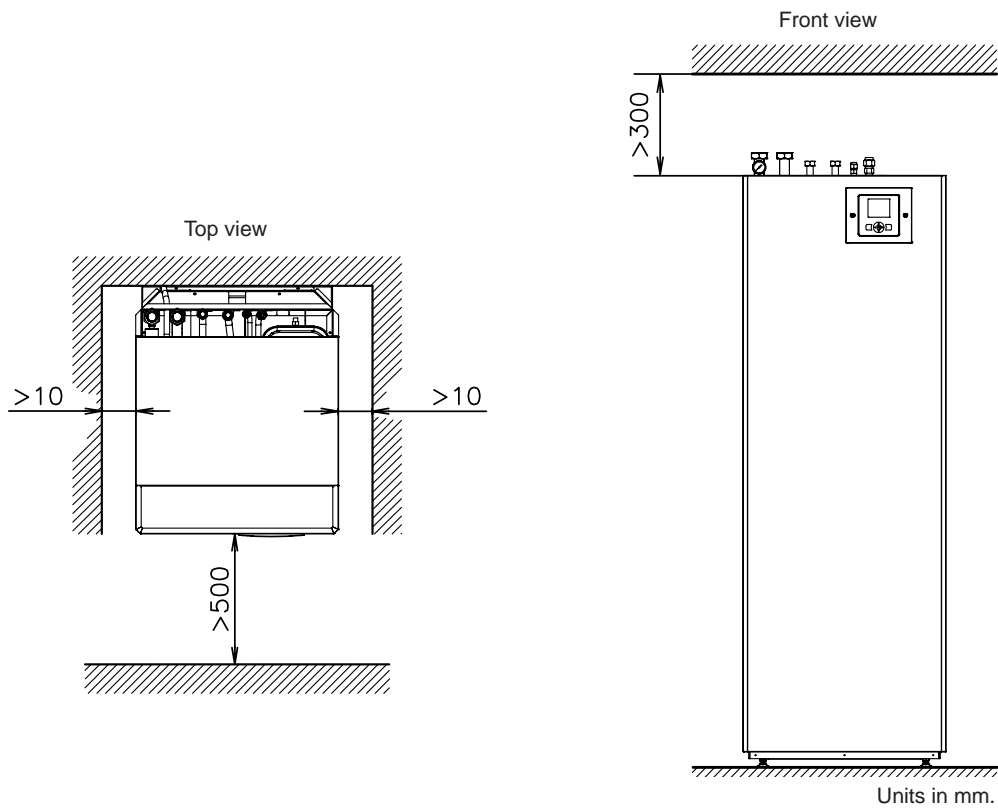

◆ Model for solar combination

RWD-(2.0-6.0)NWSE-260S

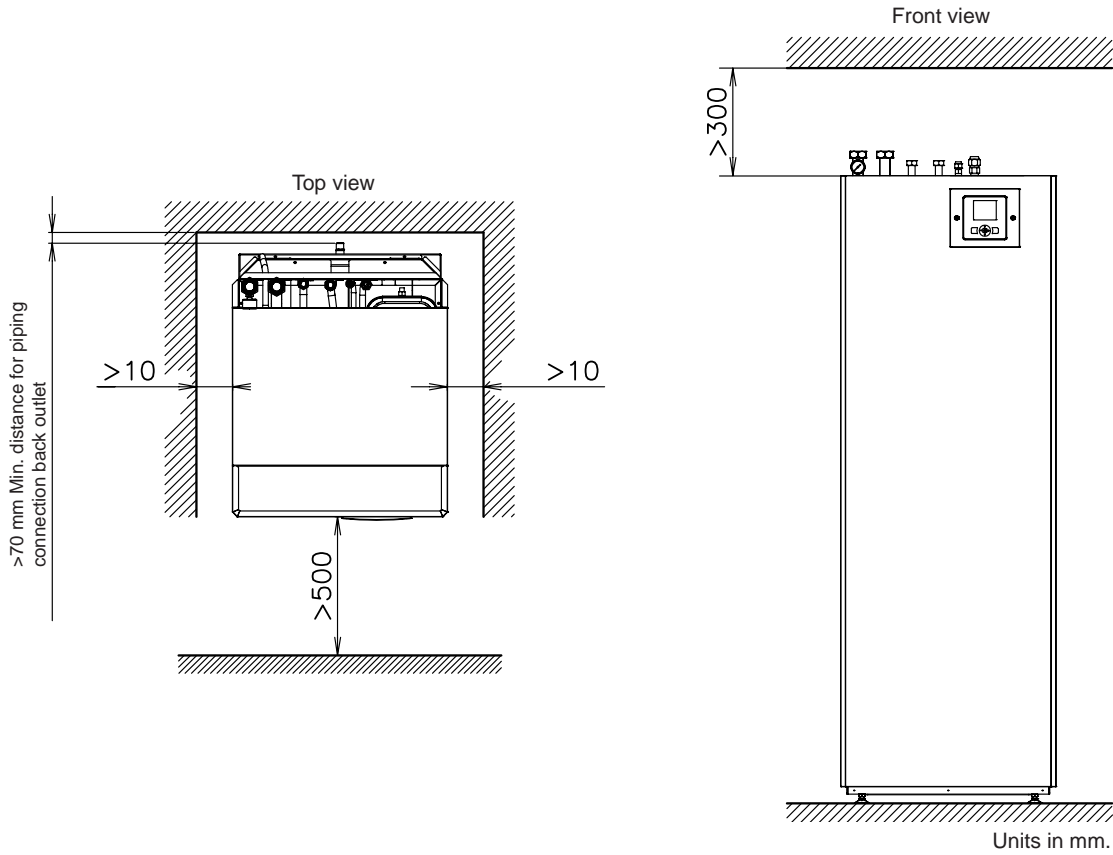

7.2.2.3 YUTAKI S80

Type 1: Indoor unit alone

RWH-(4.0-6.0)(V)NFE

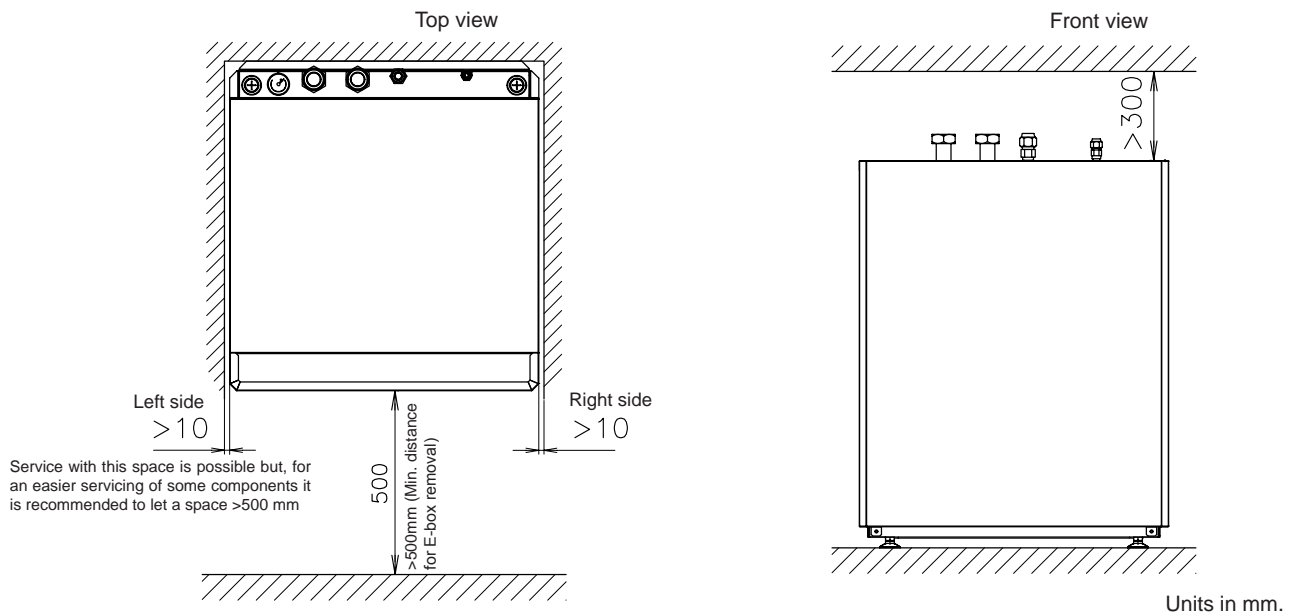

◆ Type 1: Indoor unit for operation with remote domestic hot water tank

RWH-(4.0-6.0)(V)NFW E

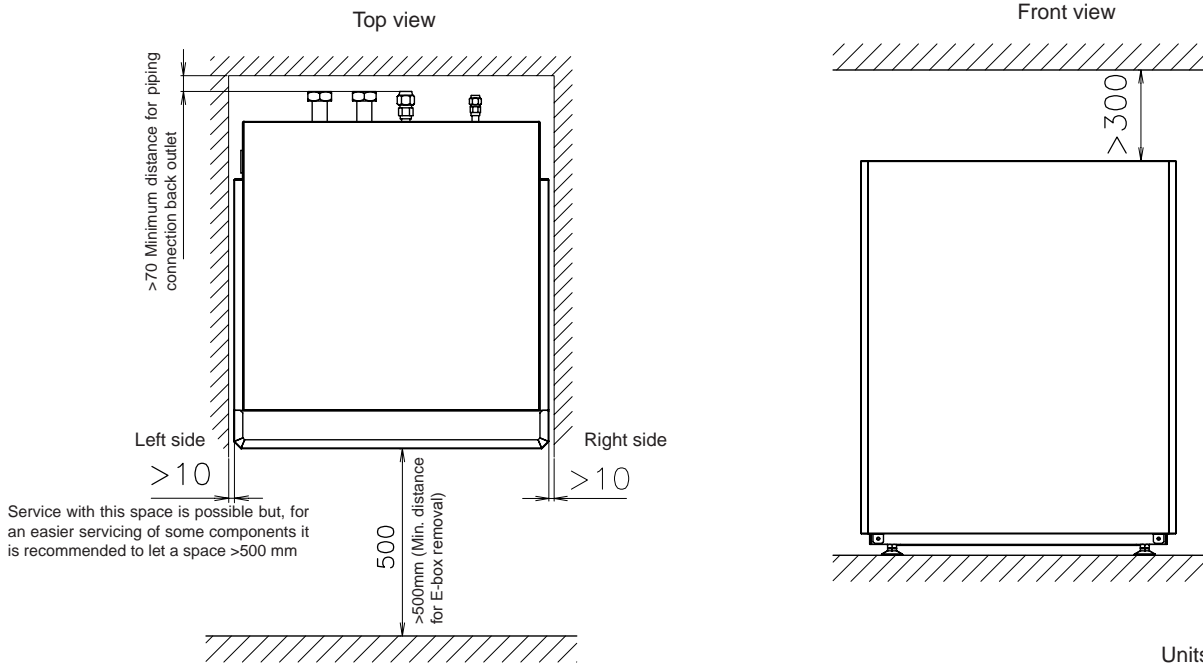

◆ Type 2: Indoor unit + Domestic hot water tank on top of the unit

RWH-(4.0-6.0)(V)NFW E + DHWS(200/260)S-2.7H2E

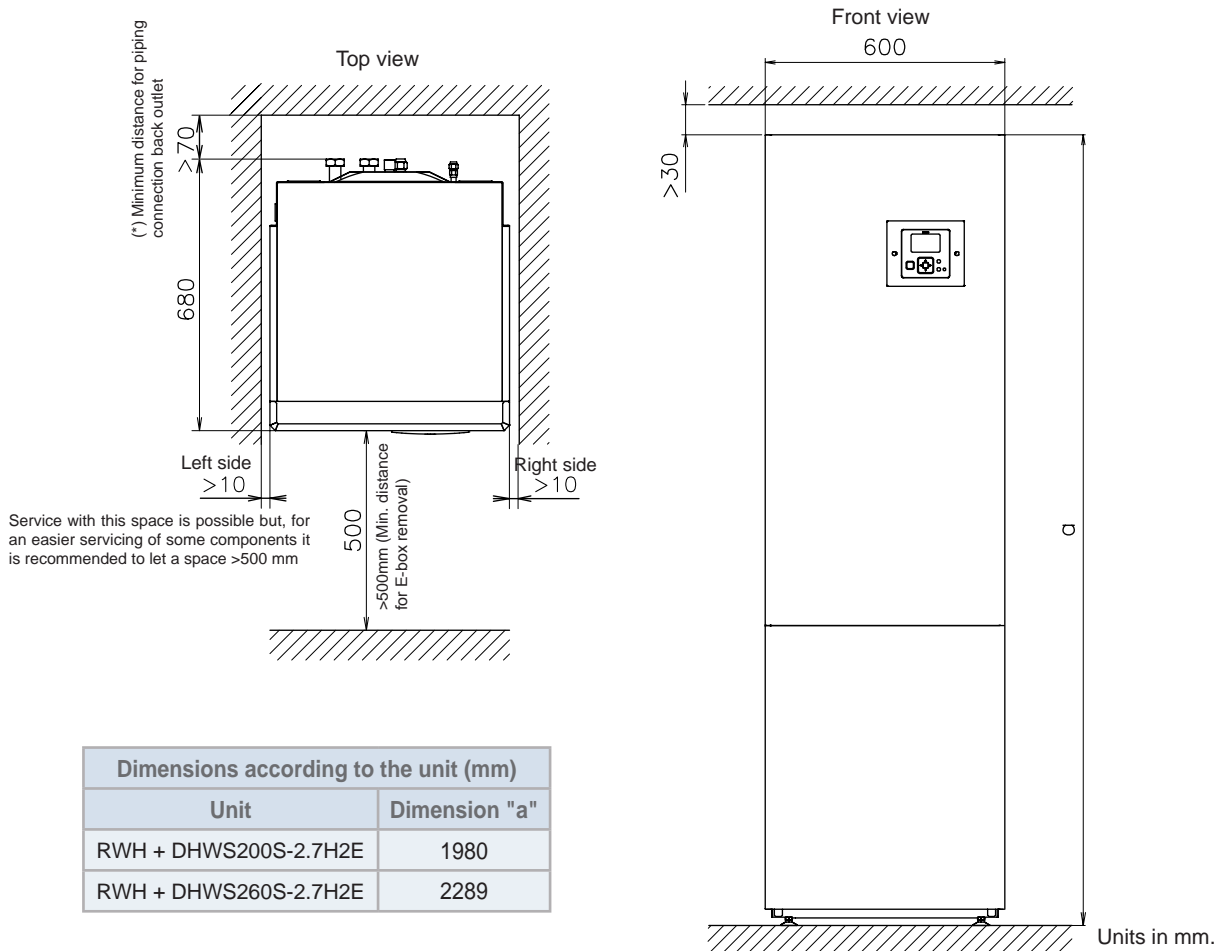

◆ Type 2: Indoor unit + Domestic hot water tank beside the indoor unit

RWH-(4.0-6.0)(V)NFWE + DHWS(200/260)S-2.7H2E

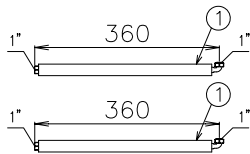
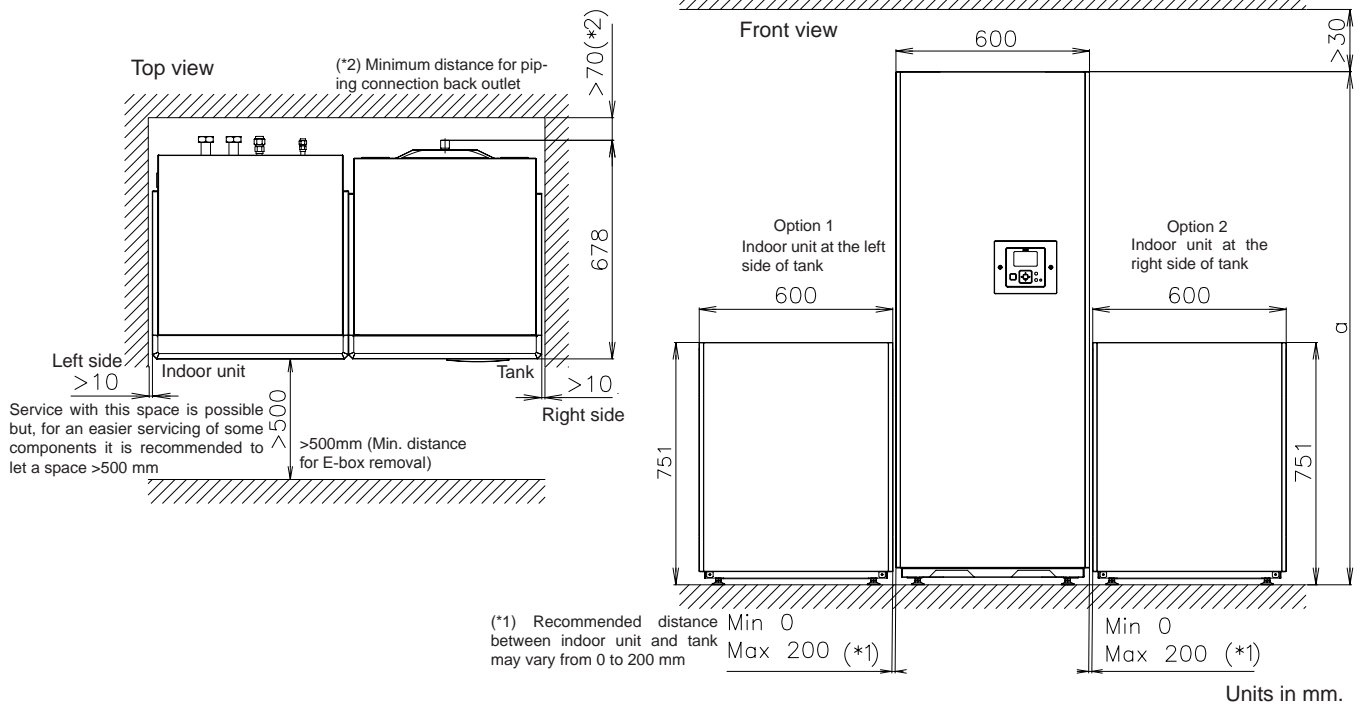

Dimensions according to the unit (mm)	
Unit	Dimension "a"
RWH + DHWS200S-2.7H2E	1980
RWH + DHWS260S-2.7H2E	2289

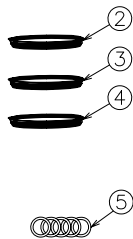

Mark	Part name	Remarks
1	Flexible water pipe (x4)	For heating coil inlet and outlet connections of indoor unit and DHW tank
2	Extension cables	For tank electric heater
3	Extension cables	For tank thermistor
4	Extension cables	For unit controller
5	Gasket (x5)	Gaskets (x5) for each flexible water pipe end (+1 for spare)



7.2.3 Monobloc system - YUTAKI M

RASM-3VNE

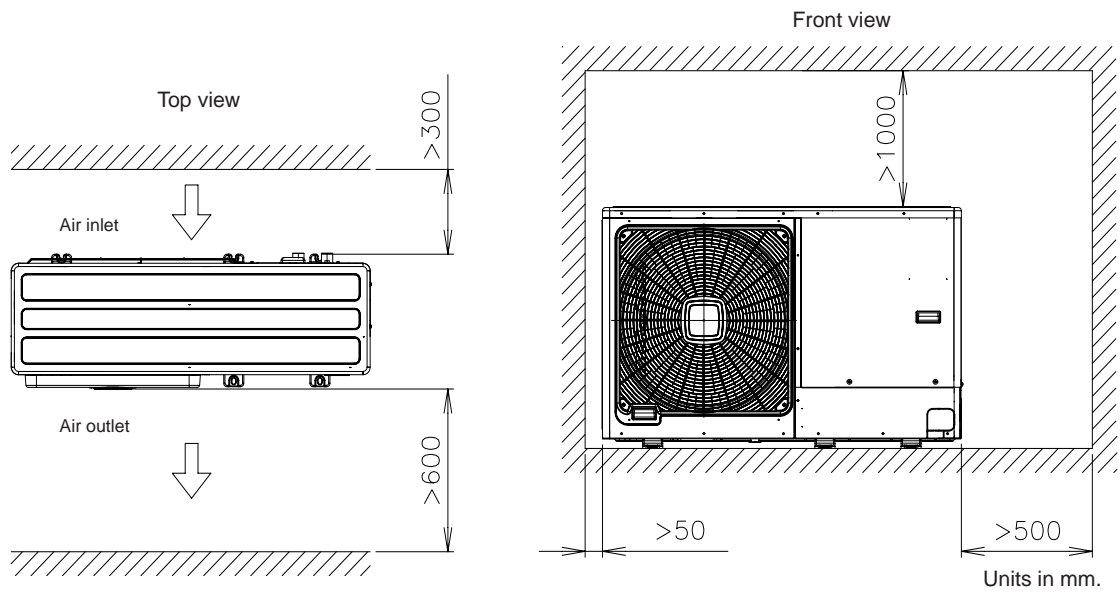

RASM-(4-6)(V)NE

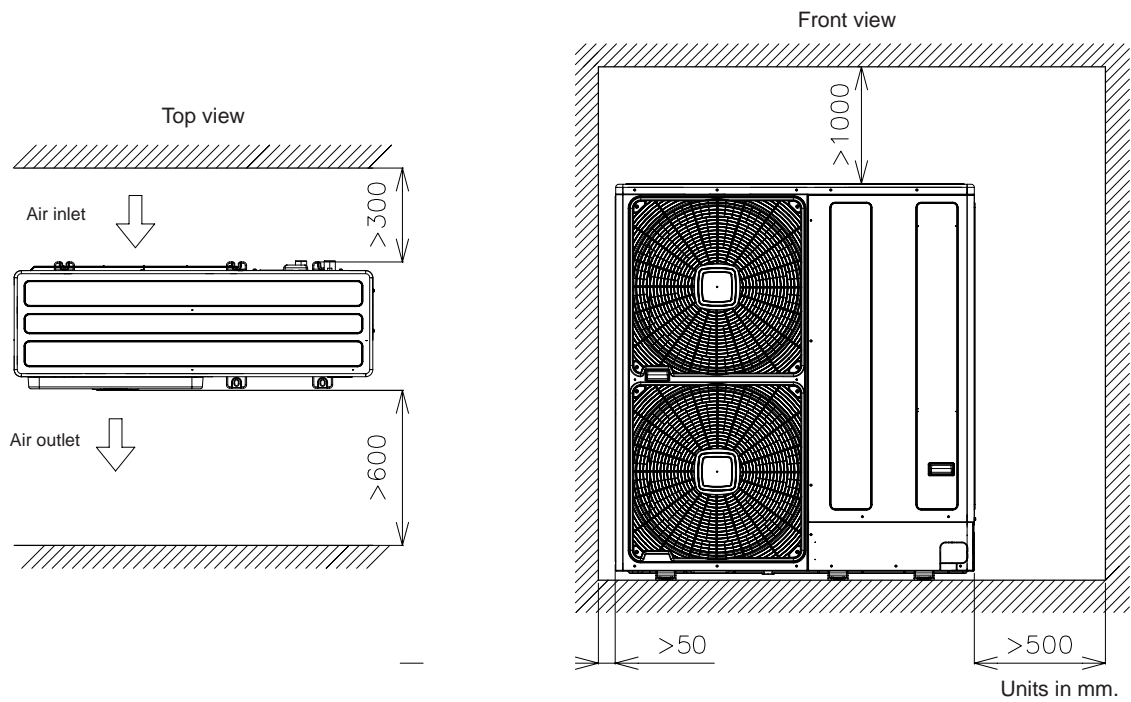

8 . Refrigerant cycle and hydraulic circuit

Index

8.1	Refrigerant cycle and hydraulic circuit for Split system	192
8.1.1	YUTAKI S	192
8.1.2	YUTAKI S COMBI.....	195
8.1.3	YUTAKI S80	197
8.1.3.1	Indoor unit standalone version.....	197
8.1.3.2	Indoor unit for integrated tank version	198
8.2	Refrigerant cycle and hydraulic circuit for Monobloc system - YUTAKI M	199

◆ RAS-(8/10)WHNPE + RWM-(8.0-10.0)NE

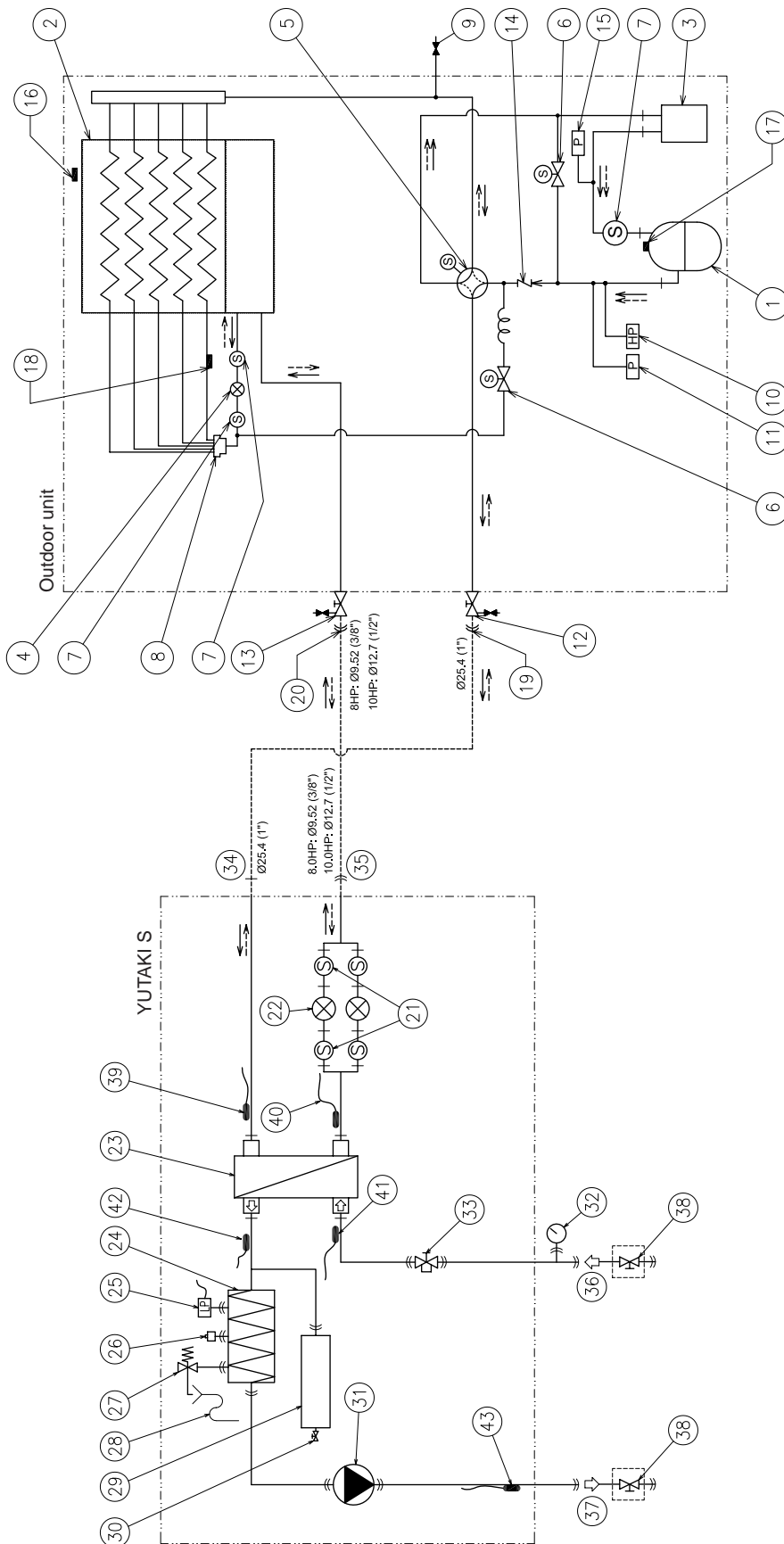

Heating refrigerant flow	Cooling refrigerant flow	Water flow (Heating/Cooling)	Field supplied piping line	Flare nut connection	Brazed connection	Refrigerant
→	←	↑	---	→	+	R410A

No.	Part name
1	Compressor
2	Air side heat exchanger
3	Accumulator
4	OU electronic expansion valve
5	4-way valve
6	Solenoid gas for by-pass
7	OU refrigerant strainer
8	Distributor
9	Refrigerant check joint

No.	Part name
10	High pressure switch for protection
11	Sensor for refrigerant pressure
12	Stop valve for gas line
13	Stop valve for liquid line
14	Check valve
15	Pressure switch for control
16	Ambient thermistor
17	Discharge gas thermistor
18	Pipe thermistor

No.	Part name
19	OU refrigerant gas connection
20	OU refrigerant liquid connection
21	IU refrigerant strainer
22	IU electronic expansion valve
23	Water side heat exchanger
24	Water electric heater
25	Low pressure switch
26	Air purger
27	Safety valve

No.	Part name
28	Drain pipe
29	Expansion vessel
30	Air valve for pressure regulation of expansion vessel
31	Water pump
32	Manometer
33	Water strainer
34	IU refrigerant gas connection
35	IU refrigerant liquid connection

No.	Part name
36	Water inlet connection
37	Water outlet connection
38	Shut-off valve (Accessory)
39	Gas pipe thermistor (Heating)
40	Liquid pipe thermistor (Heating)
41	Water inlet thermistor
42	PHEX water outlet thermistor
43	Water outlet thermistor

8.1.2 YUTAKI S COMBI

◆ RAS-(2-3)WHVNP + RWD-(2.0-3.0)NW(S)E-(200/260)S-(K)

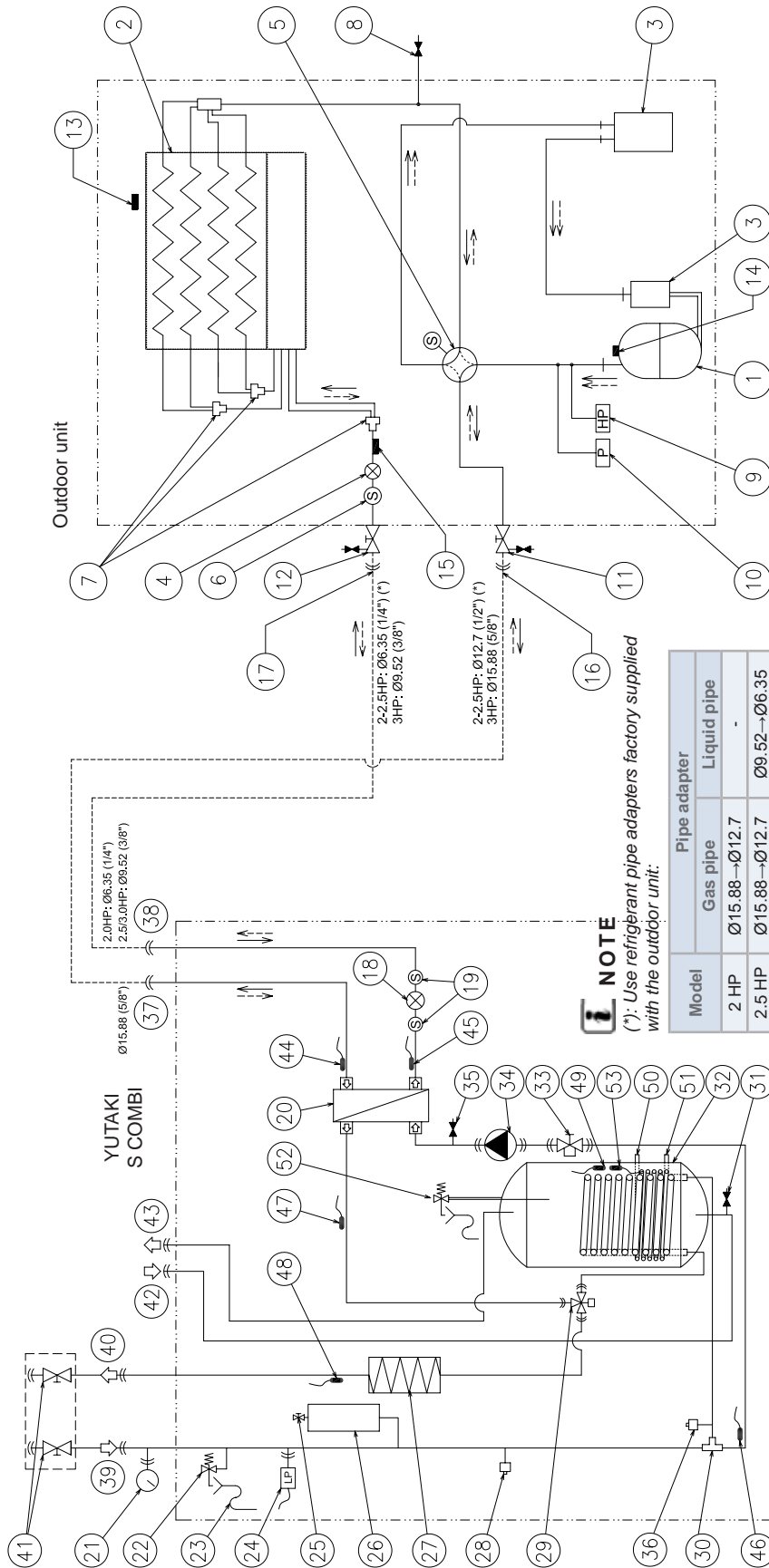

Heating refrigerant flow	Cooling refrigerant flow	Water flow (Heating/Cooling)	Field supplied piping line	Flare nut connection	Brazed connection	Refrigerant
→	←	↑	---	→	+	R410A

No.	Part name
1	Compressor
2	Air side heat exchanger
3	Accumulator
4	OU electronic expansion valve
5	4-way valve
6	OU refrigerant strainer
7	Distributor
8	Refrigerant check joint
9	High pressure switch for protection
10	Pressure switch for control
11	Stop valve for gas line
12	Stop valve for liquid line
13	Ambient thermistor
14	Discharge gas thermistor
15	Pipe thermistor
16	OU refrigerant gas connection
17	OU refrigerant liquid connection
18	OU electronic expansion valve
19	IU refrigerant strainer
20	Water side heat exchanger
21	Manometer
22	Safety valve
23	Drain pipe
24	Low pressure switch
25	Air valve for pressure regulation of expansion vessel
26	Expansion vessel
27	Water electric heater
28	Air purger
29	3-way valve
30	T-branch
31	Drain port (For DHW)
32	Domestic hot water tank
33	Water strainer
34	Water pump
35	Drain port (For indoor unit water)
36	Manual air purger
37	IU refrigerant gas connection
38	IU refrigerant liquid connection
39	Water inlet (DHW)
40	Water outlet (DHW)
41	Water inlet (Space heating)
42	Water outlet (Space heating)
43	Shut-off valve (Accessory)
44	IU refrigerant gas pipe thermistor
45	IU refrigerant liquid pipe thermistor
46	Water inlet thermistor
47	PHEx water outlet thermistor
48	Water outlet heat pump thermistor
49	DHW thermistor
50	Solar coil inlet (For solar models)
51	Solar coil outlet (For solar models)
52	P & T relief valve (For UK market)
53	DHWT sensor (For UK market)



8.1.3 YUTAKI S80

8.1.3.1 Indoor unit standalone version

◆ RAS-(4-6)WHVNP + RWH-(4.0-6.0)(V)NFE

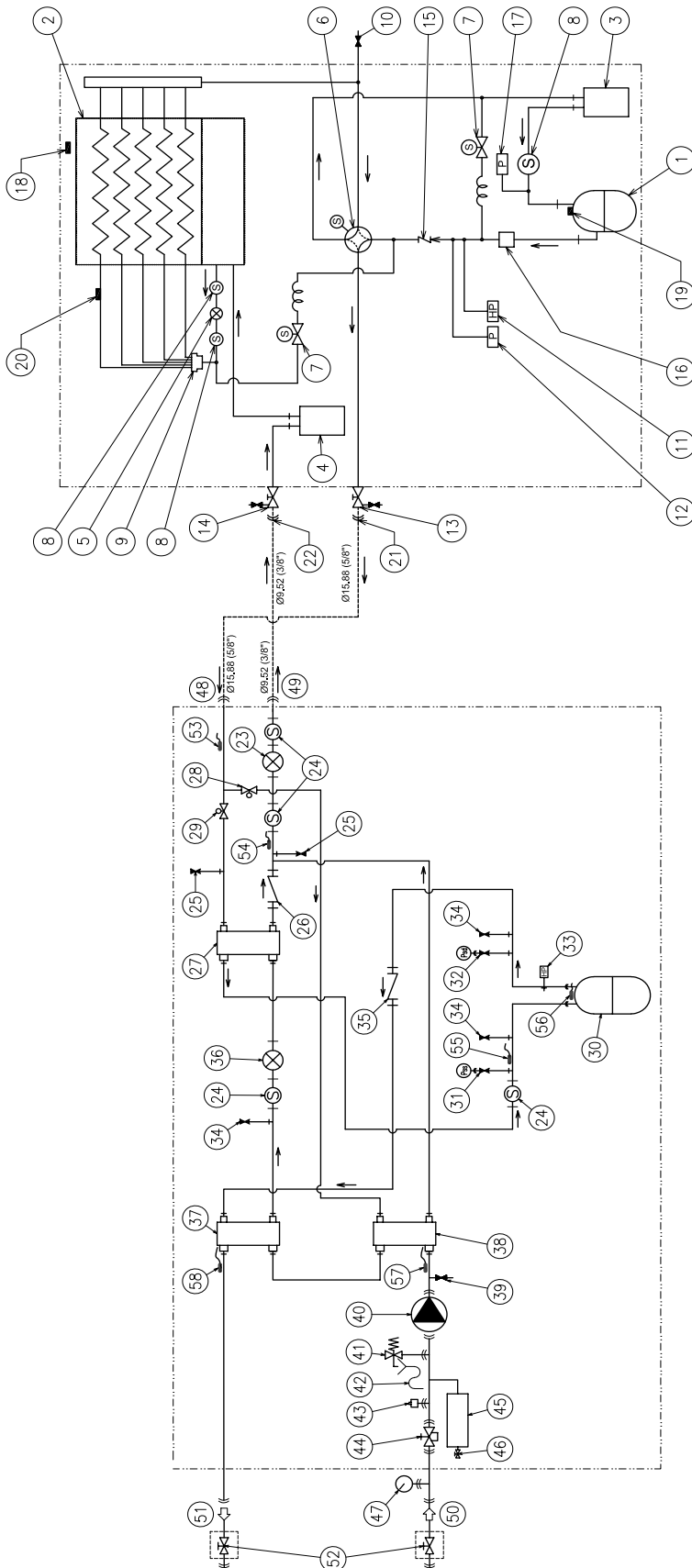

Heating refrigerant flow	Water flow	Field supplied piping line	Flare nut connection	Brazed connection	Refrigerant 1	Refrigerant 2
→	↑	---	↔	—	R-410A	R-134a

No.	Part name
1	OU compressor
2	Air side heat exchanger
3	Accumulator
4	Receiver
5	Solenoid expansion valve
6	4-way valve
7	Solenoid gas for by-pass
8	OU refrigerant strainer
9	Distributor
11	High pressure switch for protection
12	Sensor for refrigerant pressure
13	Stop valve for gas line

No.	Part name
14	Stop valve for liquid line
15	OU check valve
16	Silencer
17	Pressure switch for control
18	Ambient thermistor
19	OU comp. discharge gas thermistor
20	OU pipe thermistor
21	OU refrigerant gas connection
22	OU refrigerant liquid connection
23	OU electronic expansion valve (R-410A)
24	IU refrigerant strainer
25	IU R-410A check joint

No.	Part name
26	Check valve for R-410A
27	IU heat exchanger (R410A-R134a)
28	Solenoid valve 1 (For 1 cycle)
29	Solenoid valve 2 (For 2 cycles)
30	IU compressor
31	Low pressure sensor (Ps)
32	High pressure sensor (Pd)
33	IU high pressure switch (protection)
34	R-134a check joint
35	Check valve for R-134a
36	IU electronic expansion valve (R-134a)

No.	Part name
37	IU heat exchanger (R134a-H2O)
38	IU heat exchanger (R410A-H2O)
39	Water pressure port
40	Water pump
41	Safety valve
42	Drain pipe
43	Air purger
44	Water strainer
45	Expansion vessel
46	Air valve for pressure regulation of expansion vessel
47	Manometer

No.	Part name
48	IU refrigerant gas connection
49	IU refrigerant liquid connection
50	Water inlet connection
51	Water outlet connection
52	Shut-off valve (Accessory)
53	IU gas pipe thermistor
54	IU liquid pipe thermistor
55	IU comp. suction gas thermistor
56	IU comp. discharge gas thermistor
57	Water inlet thermistor
58	Water outlet thermistor



8.1.3.2 Indoor unit for integrated tank version

◆ RAS-(4-6)WHVNP + RWH-(4.0-6.0)(V)NFWE

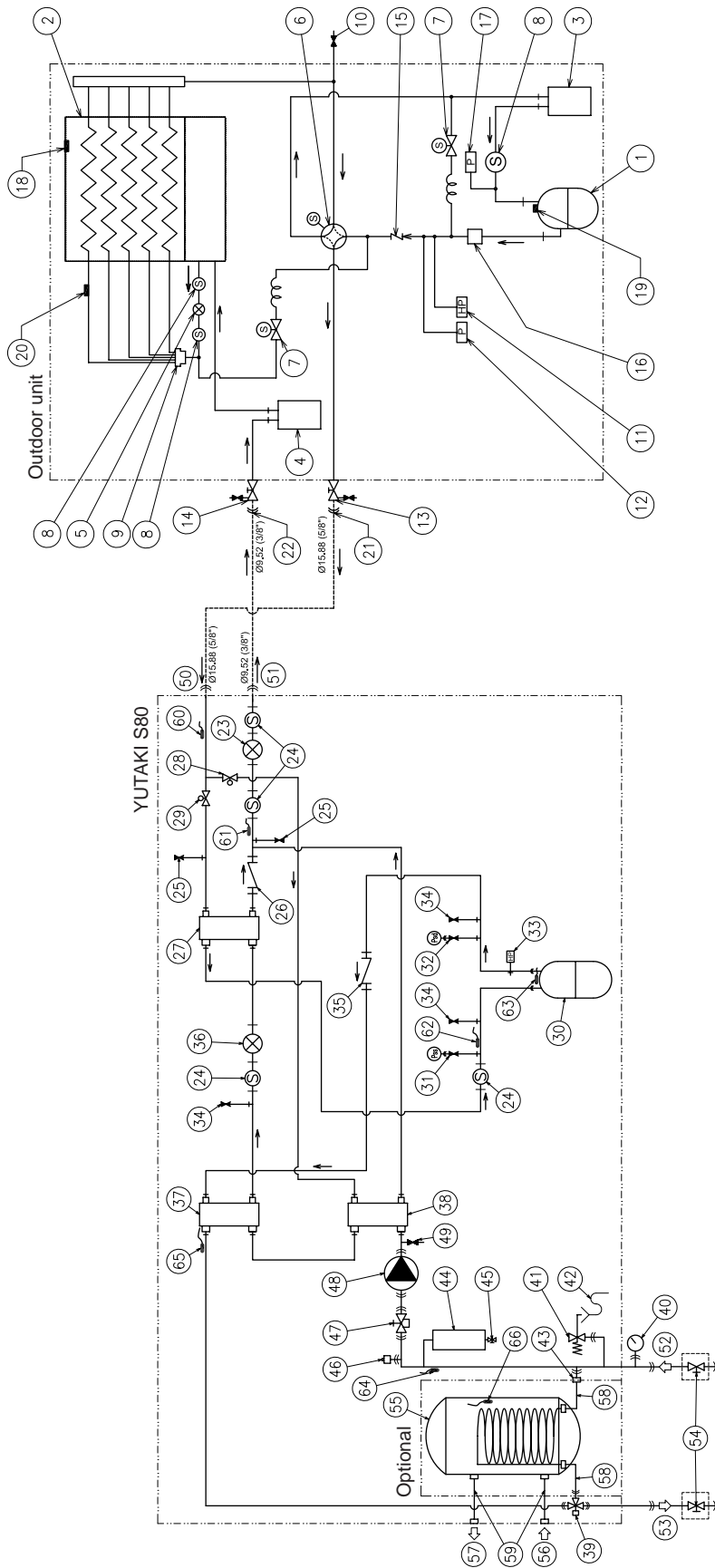

Heating refrigerant flow		Water flow		Field supplied piping line		Flare nut connection		Brazed connection		Refrigerant 1		Refrigerant 2	
No.	Part name	No.	Part name	No.	Part name	No.	Part name	No.	Part name	No.	Part name	No.	Part name
1	OU compressor	15	OU check valve	29	Solenoid valve 2 (For 2 cycles)	43	Connection for DHW tank (outlet)	56	DHW inlet	56	DHW inlet	56	DHW inlet
2	Air side heat exchanger	16	Silencer	30	IU compressor	44	Expansion vessel	57	DHW outlet	57	DHW outlet	57	DHW outlet
3	Accumulator	17	Pressure switch for control	31	Low pressure sensor (P _s)	45	Air valve for pressure regulation of expansion vessel	58	Flexible pipe for space heating	58	Flexible pipe for space heating	58	Flexible pipe for space heating
4	Receiver	18	Ambient thermistor	32	High pressure sensor (P _d)	46	Air purger	59	Flexible pipe for DHW	59	Flexible pipe for DHW	59	Flexible pipe for DHW
5	OU electronic expansion valve	19	OU comp. discharge gas thermistor	33	IU high pressure switch (protection)	47	Water strainer	60	IU gas pipe thermistor	60	IU gas pipe thermistor	60	IU gas pipe thermistor
6	4-way valve	20	OU pipe thermistor	34	R-134a check joint	48	Water pump	61	IU liquid pipe thermistor	61	IU liquid pipe thermistor	61	IU liquid pipe thermistor
7	OU refrigerant gas for by-pass	21	OU refrigerant gas connection	35	Check valve for R-134a	49	Water pressure port	62	IU comp. suction gas thermistor	62	IU comp. suction gas thermistor	62	IU comp. suction gas thermistor
8	OU refrigerant strainer	22	OU refrigerant liquid connection	36	IU electronic expansion valve (R-134a)	50	IU refrigerant gas connection	63	IU comp. discharge gas thermistor	63	IU comp. discharge gas thermistor	63	IU comp. discharge gas thermistor
9	Distributor	23	IU electronic expansion valve (R-410A)	37	IU heat exchanger (R134a-H2O)	51	IU refrigerant liquid connection	64	Water inlet thermistor	64	Water inlet thermistor	64	Water inlet thermistor
10	OU R-410A check joint	24	IU refrigerant strainer	38	IU heat exchanger (R410A-H2O)	52	Water inlet connection	65	Water outlet thermistor	65	Water outlet thermistor	65	Water outlet thermistor
11	High pressure switch for protection	25	IU R-410A check joint	39	3-way valve	53	Water outlet connection	66	DHW tank thermistor	66	DHW tank thermistor	66	DHW tank thermistor
12	Sensor for refrigerant pressure	26	Check valve for R-410A	40	Manometer	54	Shut-off valve (Accessory)						
13	Stop valve for gas line	27	IU heat exchanger (R410A-R134a)	41	Safety valve	55	Domestic hot water tank						
14	Stop valve for liquid line	28	Solenoid valve 1 (For 1 cycle)	42	Drain pipe								

9 . Refrigerant and water piping

Index

9.1	General notes before performing piping work	202
9.1.1	Piping work	202
9.1.2	Suspension of refrigerant and water pipes	202
9.2	Refrigerant circuit	203
9.2.1	Refrigerant piping	203
9.2.2	Refrigerant charge	204
9.2.2.1	Refrigerant charge amount	204
9.2.2.2	Refrigerant charge before shipment (W_0 (kg))	204
9.2.3	Precautions in the event of gas refrigerant leaks	205
9.3	Space heating and DHW	207
9.3.1	Additional hydraulic necessary elements for space heating	207
9.3.2	Additional hydraulic necessary elements for DHW	207
9.3.3	Additional hydraulic optional elements (For DHW)	210
9.3.5	Requirements and recommendations for the hydraulic circuit	210
9.3.6	Water piping	212
9.3.7	Water quality (Preliminary information)	215

9.1 General notes before performing piping work

9.1.1 Piping work

- Prepare locally-supplied copper pipes.
- Select the piping size with the correct thickness and correct material able to withstand sufficient pressure.
- Select clean copper pipes. Make sure that there is no dust or moisture inside the pipes. Blow the inside of the pipes with oxygen free nitrogen to remove any dust and foreign materials before connecting them.

NOTE

A system with no moisture or oil contamination will give maximum performance and lifecycle compared to that of a poorly prepared system. Take particular care to ensure that all copper piping is clean and dry internally.

- Cap the end of the pipe when pipe is to be inserted through a wall hole.
- Do not put pipes on the ground directly without a cap or vinyl tape at the end of the pipe.

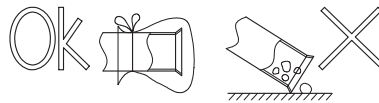

- If piping installation is not completed until next day or over a longer period of time, braze off the ends of the piping and charge with oxygen free nitrogen through a Schrader valve type access fitting to prevent moisture and particle contamination.
- It is advisable to insulate the water pipes, joints and connections in order to avoid heat loss and dew condensation on the surface of the pipes or accidental injuries due to excessive heat on piping surfaces.
- Do not use insulation material that contains NH₃, as it can damage copper pipe material and become a source of future leakage.
- It is recommended to use flexible joints for the water piping inlet and outlet in order to avoid vibration transmission.
- Refrigerant circuit and Water circuit must be performed and inspected by a licensed technician and must comply with all relevant European and national regulations.
- Proper water pipe inspection should be performed after piping work to assure there is no water leakage in the space heating or DHW circuits.

9.1.2 Suspension of refrigerant and water pipes

- Suspend the refrigerant and water piping at certain points and prevent the refrigerant and water piping from being in direct contact with the building: walls, ceilings, etc.. If there is direct contact between pipes, abnormal sound may occur due to the vibration of the piping. Pay special attention in cases of short piping lengths.

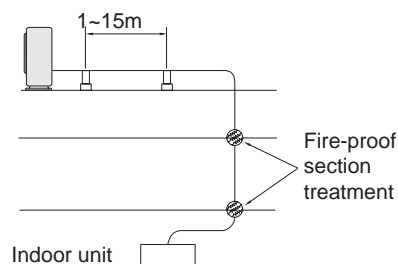

- Do not fix the refrigerant and water pipes directly with the metal fittings (refrigerant piping may expand and contract). Some examples for suspension method are shown below.

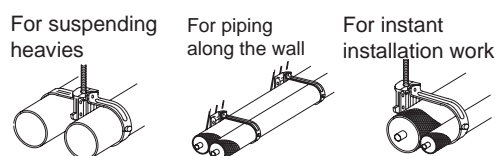

9.2 Refrigerant circuit

9.2.1 Refrigerant piping

◆ Refrigerant piping length between indoor unit and outdoor unit (For YUTAKI (S/S COMBI/S80))

The refrigerant piping length between indoor unit and outdoor unit should be designed using the following chart.

Keep the design point within the area of the chart, which is showing the applicable height difference according to piping length.

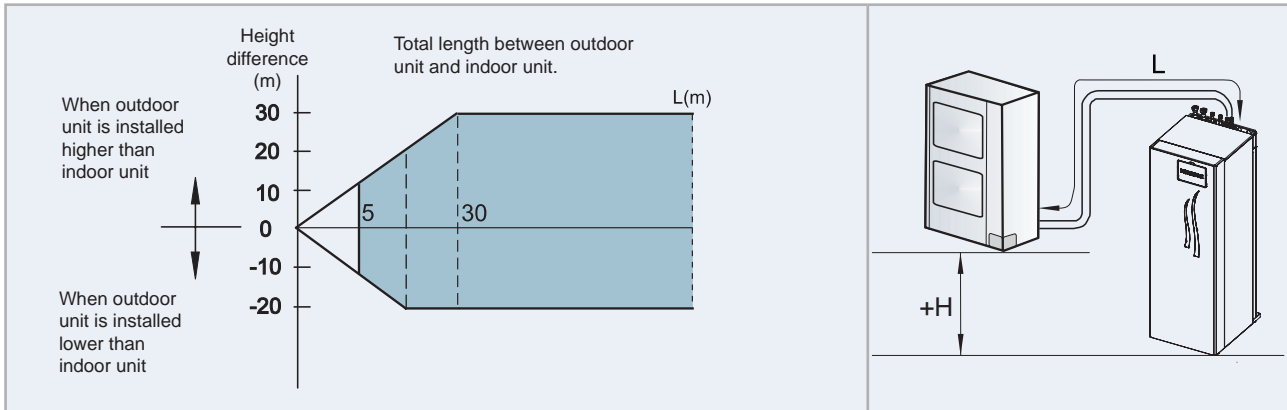

		Outdoor Unit (HP)							
		2	2.5	3	4	5	6	8	10
Maximum piping length between outdoor unit and indoor unit (Lmax)	Actual piping length (L)	50 m		75 m			70 m		
	Equivalent piping length	70 m		95 m			90 m		
Minimum piping length between outdoor unit and indoor unit (Lmin)	Actual piping length (L)	5 m							
Maximum height difference between indoor and outdoor unit (H)	Outdoor unit higher than indoor unit					30 m			
	Indoor unit higher than outdoor unit					20 m			

◆ Refrigerant piping size

Piping connection size of outdoor unit & indoor unit

Outdoor unit & YUTAKI M			Indoor unit		
Model	Pipe size		Model	Pipe size	
	Gas pipe	Liquid pipe		Gas pipe	Liquid pipe
2 HP	Ø 12.7 (1/2") (*)	Ø 6.35 (1/4")	2.0 HP	Ø 15.88 (5/8") (*)	Ø 6.35 (1/4")
2.5 HP		Ø 6.35 (1/4") (*)	2.5 HP		Ø 9.52 (3/8") (*)
(3-6) HP	Ø 15.88 (5/8")	Ø 9.52 (3/8")	(3.0-6.0) HP	Ø 15.88 (5/8")	Ø 9.52 (3/8")
8 HP	Ø 25.4 (1")	Ø 9.52 (3/8")	8 HP	Ø 25.4 (1")	Ø 9.52 (3/8")
10 HP		Ø 12.7 (1/2")	10 HP		Ø 12.7 (1/2")

i NOTE

(*): The refrigerant gas piping size for 2/2.5 HP and the refrigerant liquid piping size of 2.5 HP are different between outdoor and indoor unit, so refrigerant pipe adapters are required. These pipe adapters are factory supplied with the outdoor unit.

Model	Pipe adapter	
	Gas pipe	Liquid pipe
2 HP	Ø15.88→Ø12.7	-
2.5 HP	Ø15.88→Ø12.7	Ø9.52→Ø6.35

- For 8 and 10 HP, the gas pipe accessory with a flare nut (factory-supplied silencer) shall be brazed to the field supplied gas line, and connected to the gas valve.

9.2.2 Refrigerant charge

9.2.2.1 Refrigerant charge amount

YUTAKI (S / SCOMBI)

The R410A refrigerant is factory charged in the outdoor unit with a refrigerant charge amount for 15 m of piping length between outdoor and indoor unit.

YUTAKI S80

The YUTAKI S80 has two refrigerant circuits. The R410A circuit (1st cycle) works with this refrigerant while the indoor circuit (2nd cycle) works with R134a refrigerant. Piping connections must be performed in the R410A cycle between the outdoor unit and the indoor unit.

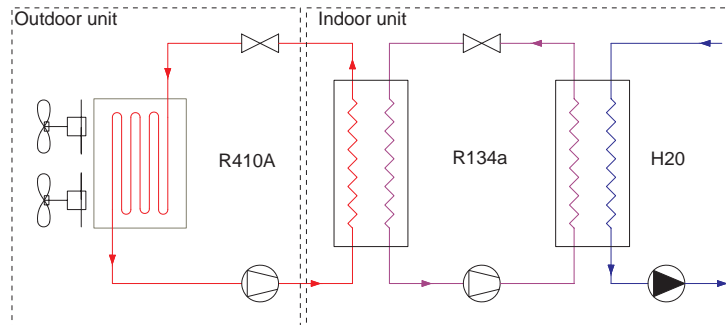

- The 1st cycle (R410A) is factory charged in the outdoor unit with a refrigerant charge amount for 15 m of piping length between outdoor and indoor unit.
- The 2nd cycle (R134a) connections are factory installed and refrigerant charged so no piping work or refrigerant charge is needed.



NOTE

- Refer to the outdoor unit *Installation and operation manual* to charge the R410A refrigerant inside the indoor unit.



CAUTION

- For YUTAKI S80, supply power to the indoor unit and switch the DSW1-2 ON of its PCB1. Thereby, solenoid valves SV1 and SV2 of the indoor unit will open to allow the operation of vacuum and refrigerant charge inside the indoor unit. It is very important to remind to switch the DSW1-2 OFF when finishing the whole procedure.
- In some circumstances and depending on installation conditions (long pipe length between outdoor and indoor units, different height between units, certain setting conditions, etc...) may drive to protection code P-06, and in some sites also to alarm 103 or 104. In order to increase the endurance against this issue, it is recommended to add extra refrigerant R410A charge +20% in the Outdoor unit. Application guidelines:

	Alarm 103 or 104	Action
Normal	No Alarm	Do nothing. Keep your current software and charge quantity
Alarm 103 & 104 (CASE A)	Only one alarm at commissioning procedure or only one case (after this, no alarms has been found)	Revise commissioning aspects following Yutaki S80 Service Manual (correct vacuuming , compressor C-heater enough long operation prior to starting, etc).
Alarm 103 & 104 (CASE B)	Alarm showed randomly often.	It is necessary to charge additional +20% of refrigerant R410A of the outdoor unit nominal charge

YUTAKI M

YUTAKI M unit is a Monobloc system (closed refrigerant circuit) which has been factory charged, so additional refrigerant charge is not required.

9.2.2.2 Refrigerant charge before shipment (W_0 (kg))

YUTAKI (S / SCOMBI)

Outdoor unit model	W_0 (kg)
RAS-2WHVNP	1.4
RAS-2.5WHVNP	1.5
RAS-3WHVNP	1.7
RAS-4WH(V)NPE	3.3
RAS-(5/6)WH(V)NPE	3.4
RAS-8WHNPE	5.0
RAS-10WHNPE	5.3

YUTAKI S80

Model		W ₀ (kg) R410A	W ₀ (kg) R134a
Outdoor unit	RAS-4WH(V)NPE	3.3	-
	RAS-(5/6)WH(V)NPE	3.4	-
Indoor unit	RWH-(4.0-6.0)(V)NF(W)E	-	1.9

YUTAKI M

Model	W ₀ (kg)
RASM-3VNE	2.4
RASM-4(V)NE	2.8
RASM-(5/6)(V)NE	3.1

9.2.3 Precautions in the event of gas refrigerant leaks

The installers and those responsible for drafting the specifications are obliged to comply with local safety codes and regulations in the case of refrigerant leakage.

**CAUTION**

- Check for refrigerant leakage in detail. If a large refrigerant leakage occurred, it would cause difficulty with breathing or harmful gases would occur if a fire were in the room.
- If the flare nut is tightened too hard, it may crack over time and cause refrigerant leakage.

◆ Maximum permitted concentration of HFCs

YUTAKI (S / SCOMBI / S80)

The refrigerant R410A (charged in the outdoor unit) and the refrigerant R134a (in case of YUTAKI S80 indoor unit) are incombustible and non-toxic gases. However, if leakage occurs and gas fills a room, it may cause suffocation.

The maximum permissible concentration of HFC gas according to EN378-1 is:

Refrigerant	Maximum permissible concentration (kg/m ³)
R410A	0.44
R134a	0.25

The minimum volume of a closed room where the system is installed to avoid suffocation in case of leakage is:

System combination		Minimum volume (m ³)
YUTAKI (S / SCOMBI)	2 HP	3.2
	2.5 HP	3.5
	3 HP	3.9
	4 HP	7.5
	5/6 HP	7.8
YUTAKI S	8 HP	11.4
	10 HP	12.1
YUTAKI S80	4-6 HP	7.6

The formula used for the calculation of the maximum allowed refrigerant concentration in case of refrigerant leakage is the following:

R	R: Total quantity of refrigerant charged (kg)
— = C	V: Room volume (m ³)
V	C: Refrigerant concentration

If the room volume is below the minimum value, some effective measure must be taken account after installing to prevent suffocation in case of leakage.

◆ Countermeasure in the event of possible refrigerant leakage

The room must have the following features to prevent suffocation in case a refrigerant leakage occurs:

- 1 Provide a shutterless opening which will allow fresh air to circulate into the room.
- 2 Provide a doorless opening of 0.15% or more size to the floor area.
- 3 There must be a ventilator fan connected to a gas leak detector, with a ventilator capacity of 0.4 m³/min or higher per Japanese refrigeration ton (= compressor displacement volume / (5.7 m³/h (R410A) or 14.4 m³/h (R134a)) of the air conditioning system using the refrigerant.

Model	Tonnes
RAS-2WHVNP	0.88
RAS-2.5WHVNP	1.14
RAS-3WHVNP	1.35
RAS-(4-6)WH(V)NPE	2.27
RAS-8WHNPE	3.16
RAS-10WHNPE	4.11

Model		Tonnes	
		R410A	R134a
Outdoor unit	RAS-(4-6)WH(V)NPE	2.27	-
Indoor unit	RWH-(4.0-6.0)(V)NF(W)E	-	1.61

i NOTE

Always take the maximum value between the R410A and R134a.

- 4 Pay special attention to the place, such as a basement, etc., where the refrigerant can stay, since refrigerant is heavier than air.

Example:

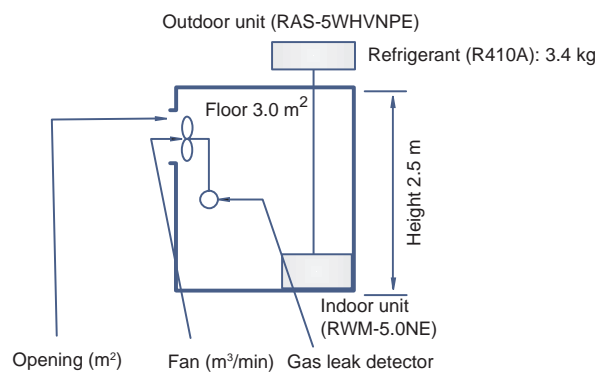

R (kg)	V (m ³)	C (kg/m ³)	Countermeasure
3.4	7.5	0.46	1.0 m ³ /min fan linked with gas leak detector or 0.5 m ² opening

YUTAKI M

YUTAKI M is an appliance designed to be installed outdoors. Should it be covered by an enclosure, this shall be done according to the EN378 (KHK standard can also be considered as a reference), so that the refrigerant concentration be below 0.44 kg/m³ (i.e., provide a shutterless opening that will allow fresh air to flow into the enclosure).

9.3 Space heating and DHW



DANGER

Do not connect the power supply to the indoor unit prior to filling the space heating and DHW circuits with water and checking water pressure and the total absence of any water leakage.

9.3.1 Additional hydraulic necessary elements for space heating

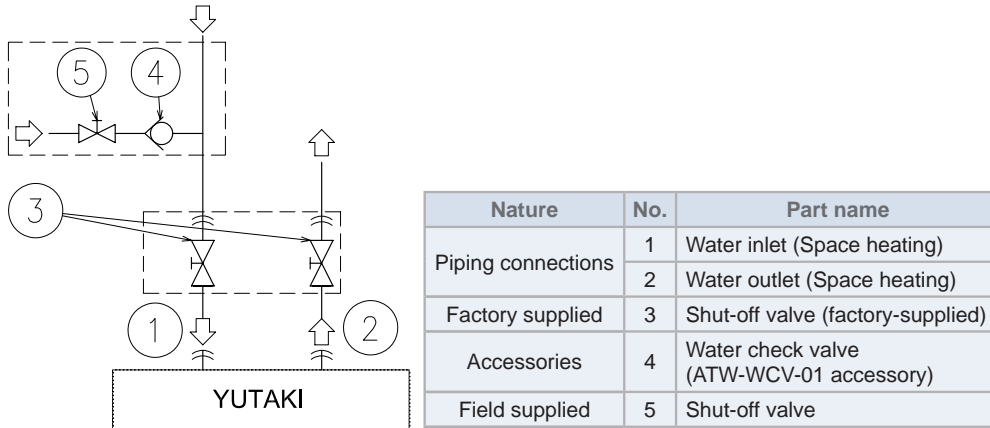

The following hydraulic elements are necessary to correctly perform the space heating water circuit:

- **Two shut-off valves (factory supplied accessory) (3)** must be installed in the indoor unit. One at the water inlet connection (1) and the other at the water outlet connection (2) in order to make easier any maintenance work.
- **A water check valve (ATW-WCV-01 accessory) (5)** with 1 shut-off valve (field supplied) (4) must be connected to the water filling point when filling the indoor unit. The check valve acts as a safety device to protect the installation against back pressure, back flow and back syphon of non-potable water into drinking water supply net.

9.3.2 Additional hydraulic necessary elements for DHW

The next hydraulic elements are necessary to correctly perform the domestic hot water circuit:

◆ COMMON

The following elements are required for all YUTAKI units.

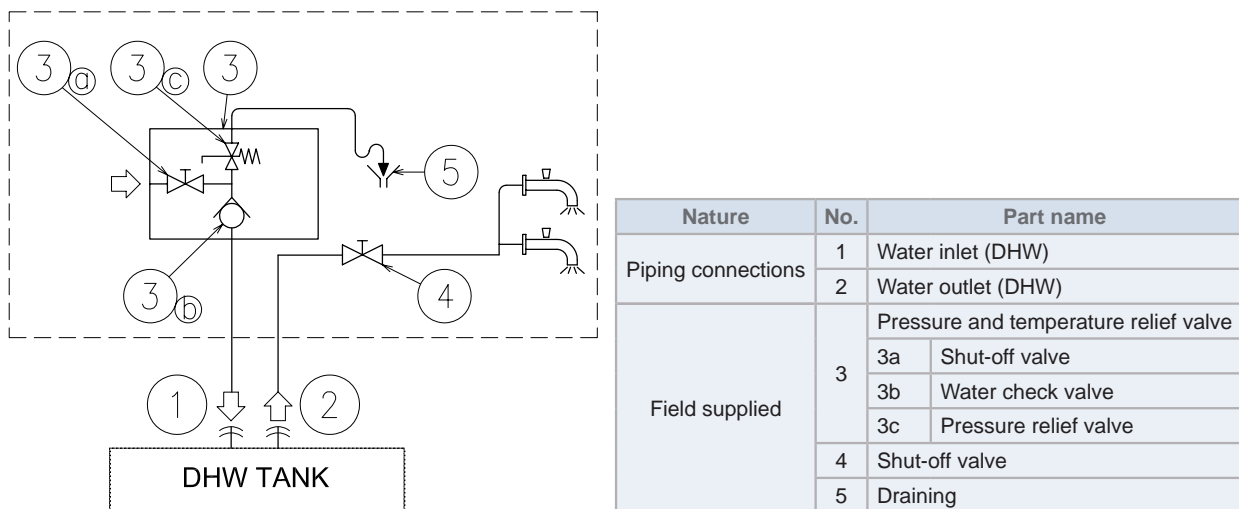

- **1 Shut-off valve (field supplied):** one shut-off valve (4) must be connected after the DHW outlet connection of the DHW tank (2) in order to make easier any maintenance work.

- **A Security water valve (Field-supplied):** this accessory (3) is a pressure and temperature relief valve that must be installed as near as possible to the DHW inlet connection of the DHW tank (1). It should ensure a correct draining (5) for the discharge valve of this valve. This security water valve should provide the following:

- Pressure protection
- Non-return function
- Shut-off valve
- Filling
- Draining

i NOTE

The discharge pipe should always be open to the atmosphere, free of frost and in continuous slope to the down side in case that water leakage exists.

- ◆ YUTAKI S / M / S80 TYPE 1 (Version for operation in DHW but with a remote tank)

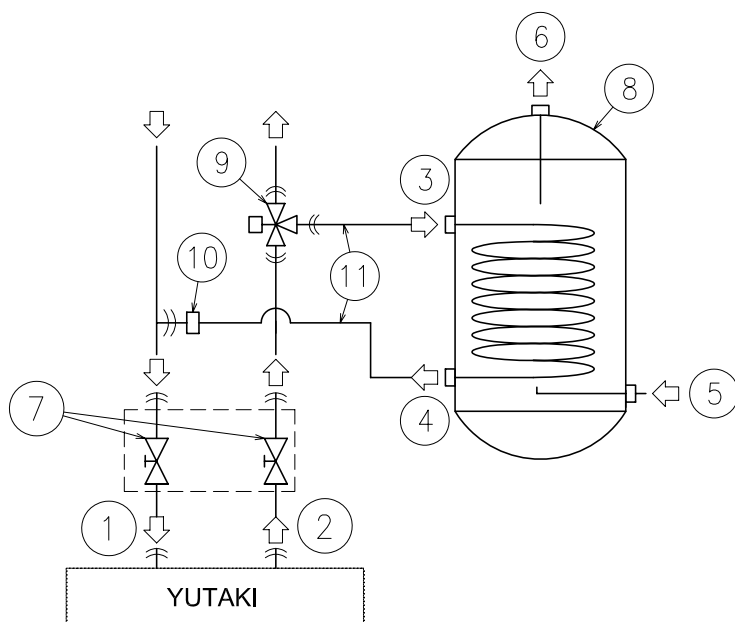

Nature	No.	Part name
Piping connections	1	Water inlet (Space heating)
	2	Water outlet (Space heating)
	3	Heating coil inlet
	4	Heating coil outlet
	5	Water inlet (DHW)
Factory supplied	6	Water outlet (DHW)
	7	Shut-off valve (factory-supplied)
Accessories	8	Domestic hot water tank DHWT-(200/300)S-3.0H2E accessory
	9	3-way valve (ATW-3WV-01 accessory)
Field supplied	10	T-branch
	11	Heating coil pipes

YUTAKI S, YUTAKI M and YUTAKI S80 TYPE 1 are not factory-supplied ready for DHW operation, but they can be used for the production of DHW if the following elements are installed:

- **A domestic hot water tank (DHWT-(200/260)S-3.0H2E accessory) (8)** has to be installed in combination with the indoor unit.
- **A 3-way valve (ATW-3WV-01 accessory) (9)** must be connected at one point of the water outlet pipe of the installation.
- **A T-branch (field supplied) (10)** must be connected at one point of the water inlet pipe of the installation.
- **Two water pipes (field supplied) (11).** One pipe between 3-way valve and the heating coil inlet (3) of the DHW tank, the other one between the T-branch and the heating coil outlet (4) of the DHW tank.

- ◆ YUTAKI S COMBI

YUTAKI S COMBI is factory-supplied ready for DHW operation (Fitted with DHW tank and 3-way valve). Only the "Common" elements are required.

◆ YUTAKI S80 TYPE 2 (Version for operation with Hitachi DHW tank)

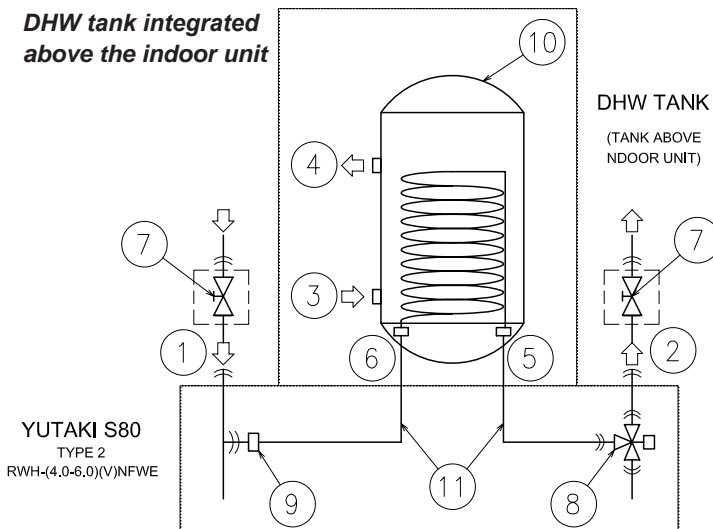
DHW tank integrated above the indoor unit

Nature	No.	Part name	
Piping connections	1	Water inlet (Space heating)	
	2	Water outlet (Space heating)	
	3	Heating coil inlet	
	4	Heating coil outlet	
	5	Water inlet (DHW)	
	6	Water outlet (DHW)	
Factory supplied	7	Shut-off valve (factory-supplied)	
	8	3-way valve	
	9	T-branch	
Accessories	10	Domestic hot water tank (DHWS(200/260)S-2.7H2E accessory)	
	11	Heating coil pipes	
	12	Flexible water pipe kit (ATW-FWP-02 accessory)	
		12a	Indoor unit pipes
		12b	DHW tank pipes
Field supplied	13	Water pipes between indoor unit and DHW tank	

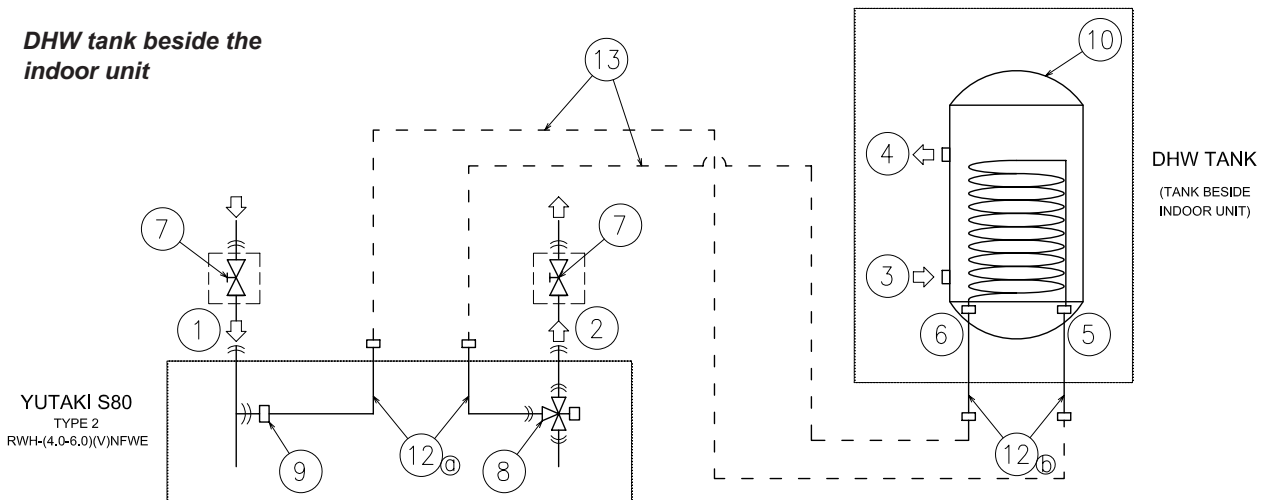
DHW tank beside the indoor unit

When installing the YUTAKI S80 indoor unit TYPE 2 (RWH-(4.0-6.0)(V)NFWFE) in combination with the HITACHI DHW tank (DHWS(200/260)S-2.7H2E) the following elements to provide DHW operation are needed:

- **The YUTAKI S80 domestic hot water tank (DHWS(200/260)S-2.7H2E accessory) (10)** is required in combination with YUTAKI S80 indoor unit TYPE 2. This tank accessory is factory-supplied with two flexible water pipes (11). Respect the following instructions depending on the DHW tank location (integrated above the indoor unit or beside it).
 - For DHW tank integrated above the indoor unit, use one of the factory-supplied pipes (11) for the connection between 3-way valve and the heating coil inlet coil of the DHW tank, and the other one for the connection between the T-branch and the heating coil outlet coil of the DHW tank accessory.
 - For DHW tank beside the indoor unit (both right or left side), the pipes factory-supplied with the DHW tank accessory (11) are not required. In this case, the dedicated HITACHI flexible water pipe kit (ATW-FWP-02 accessory) (12) is needed. This kit is provided with the following items:
 - ◆ 4 flexible water pipes (Two pipes (12a) to connect to the indoor unit (3-way (8) valve and T-branch (9)) and other two pipes (12b) to connect to the heating coil inlet/outlet connections of the DHW tank (5-6). To connect the indoor unit with the DHW tank, two additional field-supplied pipes are required (13).
 - ◆ 9 gaskets (2 gaskets for each flexible water pipe end and 1 spare gasket).
 - ◆ 3 extension cables (1 for the tank's electric heater, 1 for the tank's thermistor and 1 for the unit controller).

9.3.3 Additional hydraulic optional elements (For DHW)

In case of a recirculation circuit for the DHW circuit:

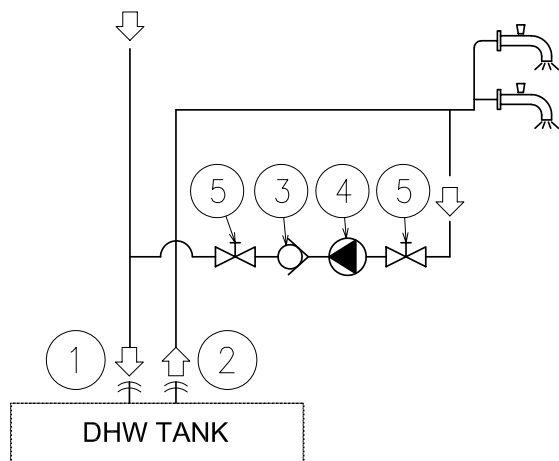

Nature	No.	Part name
Piping connections	1	Water inlet (DHW)
	2	Water outlet (DHW)
Accessories	3	Water check valve (ATW-WCV-01 accessory)
Field supplied	4	Water pump
	5	Shut-off valve

- 1 Recirculation water pump (field supplied): this water pump (3) will help to correctly recirculate the hot water to the DHW inlet.
- 1 Water check valve (ATW-WCV-01 accessory): this Hitachi accessory (4) is connected after the recirculation water pump (31) in order to ensure the non-return of water.
- 2 Shut-off valves (field supplied) (5): one before the recirculation water pump (3) and other after the water check valve accessory (4).

9.3.4 Additional hydraulic necessary elements for DHW (only for UK market)

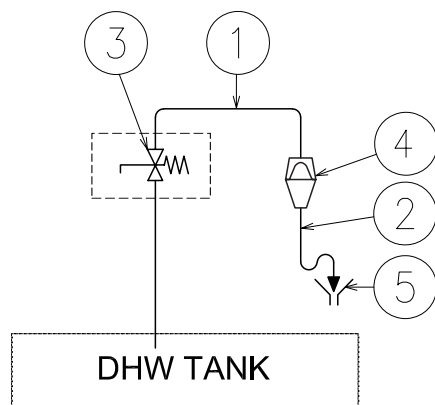

Nature	No.	Part name
Piping connections	1	T&P relief valve outlet pipe Ø15 (factory supplied)
	2	Tundish outlet pipe (Field supplied)
Accessories	3	Pressure and Temperature relief valve (Factory supplied)
Field supplied	4	Tundish (Field supplied)
	5	Drain (Field supplied)

The following accessories are necessary for the compliance of the YUTAKI S COMBI for UK market with the UK requirements referred in the UK Building Regulations 2000.

- 1 temperature and pressure relief valve (factory supplied), fitted at the hottest part of the DHW tank. This device protects the unit of excessive temperature (>96° C) and excessive pressure (>7 bar) in the DHW tank. Additionally, a Ø15 diameter pipe (factory supplied) is fitted to the outlet of the relief valve and drives the discharge to the tundish (4).
- 1 tundish(4)(field supplied), installed in a vertical position, with no more than 600 mm of pipe between the valve outlet and the tundish.
- 1 Tundish outlet pipe (2)(field supplied) with a vertical section at least 300 mm long below the tundish(4), before any elbows or bends in the pipework. This pipe should be made of metal or other material that has been demonstrated to be capable of safety withstanding temperatures and pressure of the water discharged, as it is referred in the UK Building Regulations.
- The discharge pipe from the tundish (2) must terminate in a safe place where is no risk to persons in the vicinity of the discharge. the discharge will consist of high water temperature and pressure.

9.3.5 Requirements and recommendations for the hydraulic circuit

- The maximum piping length depends on the maximum pressure availability in the water outlet pipe. Please check the pump curves.
- The indoor unit is equipped with an air purger (factory supplied) at the highest location of the Indoor Unit. If this location is not the highest of the water installation, air might be trapped inside the water pipes, which could cause system

malfunction. In that case additional air purgers (field supplied) should be installed to ensure no air enters the water circuit.

- For heating floor system, the air should be purged by means of an external pump and an open circuit to avoid air bags.
- When the unit is stopped during shut-off periods and the ambient temperature is very low, the water inside the pipes and the circulating pump may freeze, thus damaging the pipes and the water pump. In these cases, the installer shall ensure that the water temperature inside the pipes does not fall below the freezing point. In order to prevent this, the unit has a self-protection mechanism which should be activated (refer to the Service manual, "Optional functions" chapter).
- Check that the water pump of the space heating circuit works within the pump operating range and that the water flow is over the pump's minimum. If the water flow is below 12 litres/minute (6 litres/minute for 2.0/2.5/3.0HP unit), alarm is displayed on the unit.
- An additional special water filter is highly recommended to be installed on the space heating (field installation), in order to remove possible particles remaining from brazing which cannot be removed by the indoor unit water strainer.
- When selecting a DHW tank, take into consideration that the storage capacity of the tank has to meet with the daily consumption in order to avoid stagnation of water.
- Fresh water must circulate inside the DHW tank water circuit at least one time per day during the first days after the installation has been performed. Additionally, flush the system with fresh water when there is no consumption of DHW during long periods of time.
- Try to avoid long runs of water piping between the tank and the DHW installation in order to decrease possible temperature losses.
- For YUTAKI S80: When using the indoor unit in combination with the YUTAKI S80 DHW tank, the heating coil of the tank is placed in a higher position than the indoor unit air purger. Then, to totally purge the space heating circuit, it is very important that the heating coil of the tank is fully air purged.
- If the domestic cold water entry pressure is higher than the equipment's design pressure (6 bar), a pressure reducer must be fitted with a nominal value of 7 bar.
- Ensure that the installation complies with applicable legislation in terms of piping connection and materials, hygienic measures, testing and the possible required use of some specific components like thermostatic mixing valves, Differential pressure overflow valve, etc.
- The maximum water pressure is 3 bar (nominal opening pressure of the safety valve). Provide adequate reduction pressure device in the water circuit to ensure that the maximum pressure is NOT exceeded.
- Ensure that the drain pipes connected to the safety valve and to the air purger are properly driven to avoid water being in contact with unit components.
- Make sure that all field supplied components installed in the piping circuit can withstand the water pressure and the water temperature range in which the unit can operate.
- YUTAKI units are conceived for exclusive use in a closed water circuit.
- The internal air pressure of the expansion vessel tank will be adapted to the water volume of the final installation (factory supplied with 0.1 MPa of internal air pressure).
- Do not add any type of glycol to the water circuit in YUTAKI S / SCOMBI / S80 units. The use of glycol is only allowed for YUTAKI M units in order to prevent water pipes from freezing. If using glycol for the water circuit of YUTAKI M units, refer to the specific information throughout the document.
- Drain taps must be provided at all low points of the installation to permit complete drainage of the circuit during servicing.

9.3.6 Water piping

◆ Water piping length

Consider the following guidelines when designing the water circuit.

Item	YUTAKI S	YUTAKI S COMBI	YUTAKI S80		
			DHW tank above the indoor unit	DHW tank beside the indoor unit	
				Type 1	Type 2
Maximum water piping length between indoor unit and DHW tank	10 m	--	--	10 m	10 m
Maximum water piping length between indoor unit and 3-way valve	3 m	--	--	3 m	--
Maximum water piping length between 3-way valve and DHW tank	10 m	--	--	10 m	10 m

Item	YUTAKI M
Maximum water piping length between outdoor unit and domestic hot water tank	10 m
Maximum water piping length between outdoor unit and domestic hot water tank 3-way valve	10 m
Maximum total piping combination	10 m

**NOTE**

DHW Piping length. It is recommended to avoid long runs of piping between the domestic hot water tank and hot water outlet side in order to avoid heat losses

◆ Water piping size

YUTAKI S

(inches)

Model	Space heating pipes connection		
	Inlet connection	Outlet connection	Shut-off valves
(2.0-3.0)HP	G 1" (female)	G 1" (female)	G 1" (male) - G 1" (male)
(4.0-10.0)HP	G 1-1/4" (female)	G 1-1/4" (female)	G 1-1/4" (male) - G 1-1/4" (male)

YUTAKI S COMBI

(inches)

Model	Space heating connection			DHW connection			Solar connection (*)	
	Inlet connection	Outlet connection	Shut-off valves	Inlet connection	Outlet connection	P & T relief valve(**)	Inlet connection	Outlet connection
(2.0-3.0)HP	G 1" (female)	G 1" (female)	G 1" (male) - G 1" (male)	G 3/4" (female)	G 3/4" (female)	Ø15 mm	G 1/2" (female)	G 1/2" (female)
(4.0-6.0)HP	G 1-1/4" (female)	G 1-1/4" (female)	G 1-1/4" (male) - G 1-1/4" (male)	G 3/4" (female)	G 3/4" (female)	Ø15 mm	G 1/2" (female)	G 1/2" (female)

(*): Only for models for solar combination.

(**): Only for models for UK market.

YUTAKI M

(inches)

Model	Space heating pipes connection		
	Inlet connection	Outlet connection	Shut-off valves
3.0HP	G 1" (female)	G 1" (female)	G 1" (male) - G 1" (male)
(4.0-6.0)HP	G 1-1/4" (female)	G 1-1/4" (female)	G 1-1/4" (male) - G 1-1/4" (male)

YUTAKI S80 indoor unit

Version for indoor unit alone (RWH-(4.0-6.0)(V)NFE)

(inches)

Model	Space heating connection		
	Inlet connection	Outlet connection	Shut-off valves
(4.0-6.0)HP	G 1-1/4" (female)	G 1-1/4" (female)	G 1-1/4" (male) - G 1-1/4" (male)

Version for combination with DHW tank (RWH-(4.0-6.0)(V)NFWE)

(inches)

Model	Space heating connection			Heating coil connection	
	Inlet connection	Outlet connection	Shut-off valves	Inlet connection (3-way valve)	Outlet connection (T-branch)
(4.0-6.0)HP	G 1-1/4" (female)	G 1-1/4" (female)	G 1-1/4" (male) - G 1-1/4" (male)	G 1" (female)	G 1" (female)

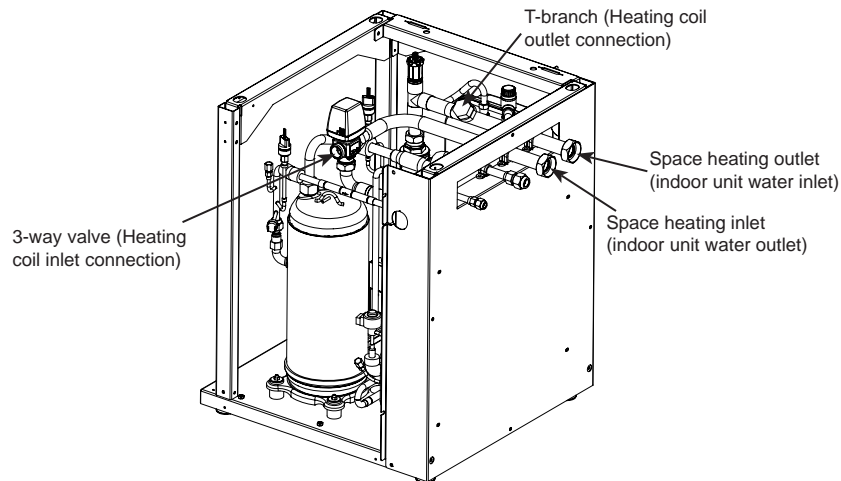

YUTAKI S80 Domestic hot water tank accessory (DHWS(200/260)S-2.7H2E)

(inches)

Model	Heating coil connection		DHW connection	
	Inlet connection	Outlet connection	Inlet connection	Outlet connection
DHWS(200/260)S-2.7H2E	G 1" (male)	G 1" (male)	G 3/4" (male)	G 3/4" (male)

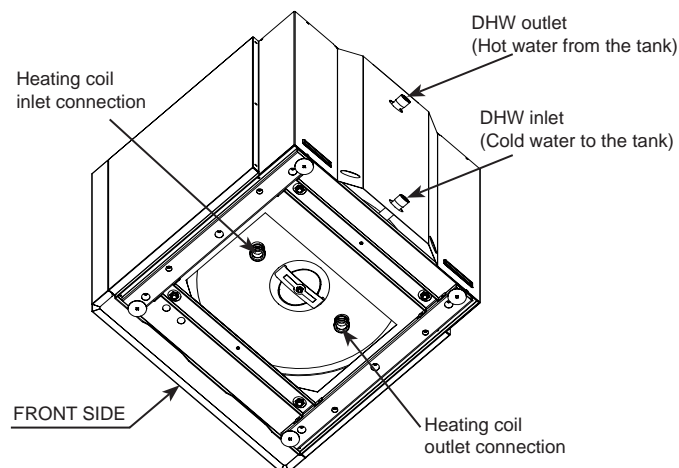

Heating coil pipes (Factory-supplied with the DHW tank accessory (DHWS(200/260)S-2.7H2E))

The domestic hot water tank accessory for combination with YUTAKI S80 indoor unit is factory-supplied with two flexible water pipes for the connection between the indoor unit and the heating coil of the domestic hot water tank, **when the DHW tank is installed integrated above the indoor unit.**

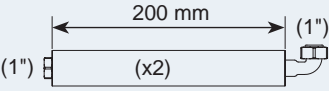
Heating coil pipes	
Item	Connection
	<p>One pipe for the connection between 3-way valve connection and heating coil inlet connection of the tank.</p> <p>The other one for the connection between T-branch connection and heating coil outlet connection of the tank.</p>

Flexible water pipe kit (ATW-FWP-02) - For domestic hot water tank installed beside the indoor unit

For DHW tank beside the indoor unit (both right or left side), the heating coil pipes factory-supplied with the DHW tank accessory are not required. In this case, the dedicated HITACHI flexible water pipe kit (ATW-FWP-02 accessory) is needed. This kit is provided with the following items:

- 4 flexible water pipes:
 - ♦ 2 pipes to connect to the indoor unit (3-way valve and T-branch)
 - ♦ 2 pipes to connect to the heating coil inlet/outlet connections of the DHW tank accessory (DHWS(200/260) S-2.7H2E).
- 9 gaskets (2 gaskets for each flexible water pipe end and 1 spare gasket).
- 3 extension cables (1 for the tank's electric heater, 1 for the tank's thermistor and 1 for the unit controller).

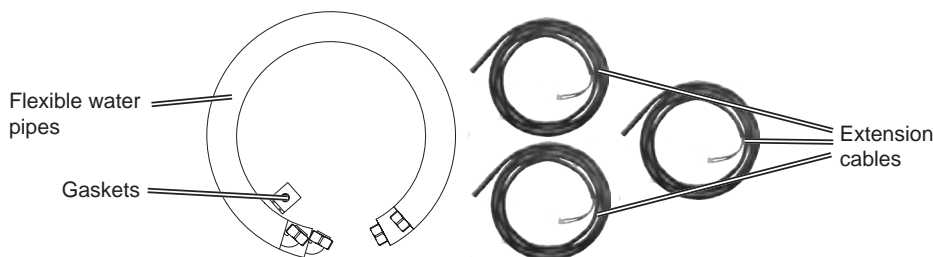

It is necessary to identify the function of each water pipe.

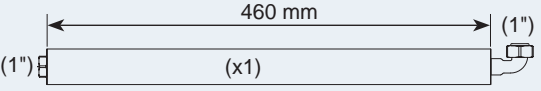
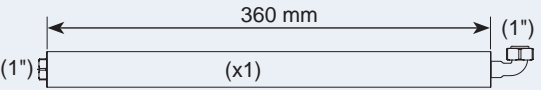
Heating coil pipes for the indoor unit	
Item	Connection
	To connect to the 3-way valve heating coil inlet connection.
	To connect to the T-branch heating coil outlet connection.

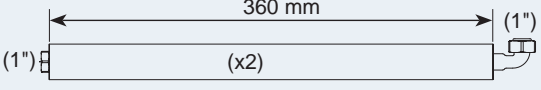
Heating coil pipes for the DHW tank accessory	
Item	Connection
	<p>One pipe to connect to the heating coil inlet connection of the tank accessory.</p> <p>The other one to connect to the heating coil outlet connection of the tank accessory.</p>

9.3.7 Water quality (Preliminary information)

**CAUTION**

- *Water quality must be according to EU council directive 98/83 EC.*
- *Water should be subjected to filtration or to a softening treatment with chemicals before application as treated water.*
- *It is also necessary to analyse the quality of water by checking pH, electrical conductivity, ammonia ion content, sulphur content, and others. Should the results of the analysis be not good, the use of industrial water would be recommended.*
- *No antifreeze agent shall be added to the water circuit.*
- *To avoid deposits of scale on the heat exchangers surface it is mandatory to ensure a high water quality with low levels of CaCO₃.*

◆ Recommendations for the DHW circuit

The following is the recommended standard water quality.

Item	DHW space	Tendency ⁽¹⁾	
	Water supplied ⁽³⁾	Corrosion	Deposits of scales
Electrical Conductivity (mS/m) (25°C) {μS/cm} (25 °C) ⁽²⁾	100~2000	●	●
Chlorine Ion (mg Cl ⁻ /l)	max. 250	●	
Sulphate (mg/l)	max. 250	●	
Combination of chloride and sulphate (mg/l)	max. 300	●	●
Total Hardness (mg CaCO ₃ /l)	60~150		●

**NOTE**

- (1): The mark "●" in the table means the factor concerned with the tendency of corrosion or deposits of scales.
- (2): The value shown in "{ }" are for reference only according to the former unit.
- (3): Water range will be according s/UNE 112076:2004 IN.

10. Electrical and control settings

Index

10.1	General check	218
10.2	System wiring diagram	221
10.3	Electrical connection	222
10.3.1	Wiring size.....	222
10.3.2	Minimum requirements of the protection devices.....	225
10.4	Transmission wiring between outdoor and indoor unit	227
10.5	Optional indoor unit wiring (accessories)	228
10.6	Setting of DIP switches and RSW switches	230
10.6.1	Outdoor unit.....	230
10.6.1.1	Location of DIP switches and rotary switches.....	230
10.6.1.2	Function of DIP switches and rotary switches.....	231
10.6.1.3	LED indication	232
10.6.2	YUTAKI unit.....	233
10.6.2.1	Location of DIP switches and rotary switches.....	233
10.6.2.2	Function of DIP switches and rotary switches.....	233
10.6.2.3	LED indication	236

10.1 General check

- Make sure that the following conditions related to power supply installation are satisfied:
 - The power capacity of the electrical installation is large enough to support the power demand of the YUTAKI system (outdoor unit + indoor unit + DHW tank (if apply)).
 - The power supply voltage is within $\pm 10\%$ of the rated voltage.
 - The impedance of the power supply line is low enough to avoid any voltage drop of more than 15% of the rated voltage.
- Following the Council Directive 2004/108/EC, relating to electromagnetic compatibility, the table below indicates the Maximum permitted system impedance Z_{max} at the interface point of the user's supply, in accordance with EN61000-3-11.

◆ Split system - Outdoor unit

Model	Power supply	Zmax (Ω)
RAS-2WHVNP	1~ 230V 50Hz	-
RAS-2.5WHVNP		-
RAS-3WHVNP		0.42
RAS-4WHVNPE		0.25
RAS-5WHVNPE		0.25
RAS-6WHVNPE		0.25
RAS-4WHNPE	3N~ 400V 50Hz	-
RAS-5WHNPE		-
RAS-6WHNPE		-
RAS-8WHNPE		-
RAS-10WHNPE		-

◆ Split system - Indoor unit

YUTAKI S

Model	Power supply	Operation mode	Zmax (Ω)
RWM-(2.0-3.0)NE	1~ 230V 50Hz	Without electric heaters	-
		With electric heater	-
		With DHW tank heater	-
		With electric and DHW tank heaters	0.26
RWM-(4.0-6.0)NE	1~ 230V 50Hz	Without electric heaters	-
		With electric heater	0.26
		With DHW tank heater	-
		With electric and DHW tank heaters	0.17
	3N~ 400V 50Hz	Without electric heaters	-
		With electric heater	-
		With DHW tank heater	-
		With electric and DHW tank heaters	-
RWM-(8.0/10.0)NE	3N~ 400V 50Hz	Without electric heaters	-
		With electric heater	-
		With DHW tank heater	-
		With electric and DHW tank heaters	0.46



NOTE

The data corresponding to DHW tank heater is calculated in combination with the domestic hot water tank accessory "DHWT-(200/300)S-3.0H2E".

YUTAKI S COMBI

Model	Power supply	Operation mode	Z _{max} (Ω)
RWD-(2.0-3.0) NW(S)E-(200/260)S(-K)	1~ 230V 50Hz	Without electric heaters	-
		With electric heater	-
		With DHW tank heater	-
		With electric and DHW tank heaters	0.28
RWD-(4.0-6.0) NW(S)E-(200/260)S(-K)	1~ 230V 50Hz	Without electric heaters	-
		With electric heater	0.26
		With DHW tank heater	-
		With electric and DHW tank heaters	0.18
	3N~ 400V 50Hz	Without electric heaters	-
		With electric heater	-
		With DHW tank heater	-
		With electric and DHW tank heaters	-

YUTAKI S80

Indoor unit alone

Model	Power supply	Operation mode	Z _{max} (Ω)	
RWH-4.0VNFE	1~ 230V 50Hz	Without DHW tank heater	0.31	
		With DHW tank heater	0.20	
RWH-5.0VNFE		Without DHW tank heater	0.27	
		With DHW tank heater	0.18	
RWH-6.0VNFE		Without DHW tank heater	0.24	
		With DHW tank heater	0.17	
RWH-4.0NFE		3N~ 400V 50Hz	Without DHW tank heater	-
			With DHW tank heater	0.38
RWH-5.0NFE	Without DHW tank heater		-	
	With DHW tank heater		0.38	
RWH-6.0NFE	Without DHW tank heater		-	
	With DHW tank heater		0.38	

Indoor unit in combination with DHW tank

Model	Power supply	Operation mode	Z _{max} (Ω)	
RWH-4.0VNFWE	1~ 230V 50Hz	Without DHW tank heater	0.31	
		With DHW tank heater	0.21	
RWH-5.0VNFWE		Without DHW tank heater	0.27	
		With DHW tank heater	0.19	
RWH-6.0VNFWE		Without DHW tank heater	0.24	
		With DHW tank heater	0.17	
RWH-4.0NFWE		3N~ 400V 50Hz	Without DHW tank heater	-
			With DHW tank heater	0.41
RWH-5.0NFWE	Without DHW tank heater		-	
	With DHW tank heater		0.41	
RWH-6.0NFWE	Without DHW tank heater		-	
	With DHW tank heater		0.41	

**NOTE**

The data corresponding to DHW tank heater is calculated in combination with the YUTAKI S80 domestic hot water tank accessory "DHWS(200/260)S-2.7H2E".

◆ Monobloc system - YUTAKI M

Model	Power supply	Operation mode	Z _{max} (Ω)
RASM-3VNE	1~ 230V 50Hz	-	0.35
		With DHW tank heater	0.22
RASM-4VNE		-	0.24
		With DHW tank heater	0.17
RASM-5VNE		-	0.24
		With DHW tank heater	0.17
RASM-6VNE	-	0.24	
	With DHW tank heater	0.17	
RASM-4NE	3N~ 400V 50Hz	-	-
		With DHW tank heater	0.31
RASM-5NE		-	-
		With DHW tank heater	0.31
RASM-6NE		-	-
		With DHW tank heater	0.30

**NOTE**

The data corresponding to DHW tank heater is calculated in combination with the domestic hot water tank accessory "DHWT-(200/300)S-3.0H2E".

- The status of Harmonics for each model, regarding compliance with IEC 61000-3-2 and IEC 61000-3-12, is as follows:

Status regarding compliance with IEC 61000-3-2 and IEC 61000-3-12	Models				
	Split system				Monobloc system
	Outdoor unit	Indoor unit			YUTAKI M
		YUTAKI S	YUTAKI S COMBI	YUTAKI S80	
Equipment complying with IEC 61000-3-2 (*) : Professional use	RAS-2WHVNP RAS-2.5WHVNP RAS-3WHVNP RAS-4WHNPE (*) RAS-5WHNPE (*) RAS-6WHNPE (*)	RWM-2.0NE RWM-2.5NE RWM-3.0NE RWM-4.0NE (3N~) RWM-5.0NE (3N~) RWM-6.0NE (3N~) RWM-8.0NE RWM-10.0NE	-	RWH-4.0NFE RWH-5.0NFE RWH-6.0NFE	RASM-4NE RASM-5NE RASM-6NE
Equipment complying with IEC 61000-3-12	RAS-4WHVNPE RAS-5WHVNPE RAS-6WHVNPE	RWM-4.0NE (1~) RWM-5.0NE (1~) RWM-6.0NE (1~)	RWD-2.0NWE-200S RWD-2.0NW(S)E-260S RWD-2.5NWE-200S RWD-2.5NW(S)E-260S RWD-3.0NWE-200S RWD-3.0NW(S)E-260S RWD-4.0NWE-260S RWD-4.0NW(S)E-260S RWD-5.0NWE-260S RWD-5.0NW(S)E-260S RWD-6.0NWE-260S RWD-6.0NW(S)E-260S	RWH-4.0VNFE RWH-5.0VNFE RWH-6.0VNFE RWH-4.0VNFWE RWH-5.0VNFWE RWH-6.0VNFWE RWH-4.0NFWE RWH-5.0NFWE RWH-6.0NFWE	RASM-3VNE RASM-4VNE RASM-5VNE RASM-6VNE
Installation restrictions may be applied by supply authorities in relation to harmonics	RAS-8WHNPE RAS-10WHNPE	-	-	-	-

- Check to ensure that existing installation (mains power switches, circuit breakers, wires, connectors and wire terminals) already complies with the national and local regulations.
- The use of the DHW tank heater is disabled as factory setting. If it is desired to enable the DHW tank heater operation during normal indoor unit operation, adjust the DSW4 pin 3 of the PCB1 to the ON position and use the adequate protections. Refer to the section "10.3 Electrical connection" for the detailed information.

10.2 System wiring diagram

Connect the units according to the following electric diagram:

- TB : Terminal board
- CB : Circuit breaker
- ELB : Earth leakage breaker
- : Internal wiring
- : Field wiring
- ⊗ : Field-supplied
- 1,2 : Outdoor-Indoor communication

YUTAKI (S / SCOMBI)

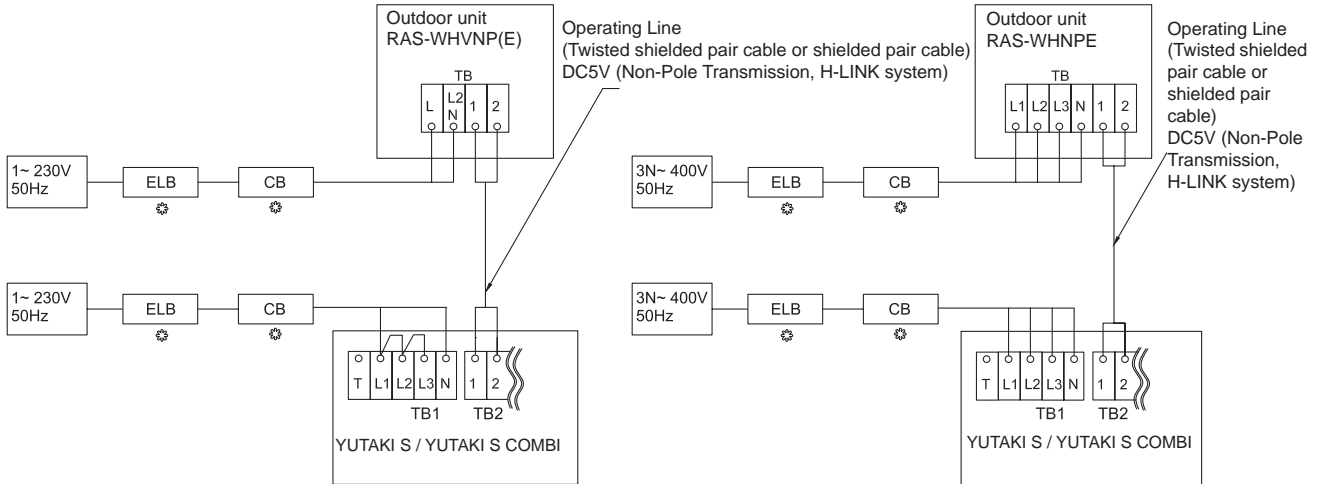

YUTAKI S80

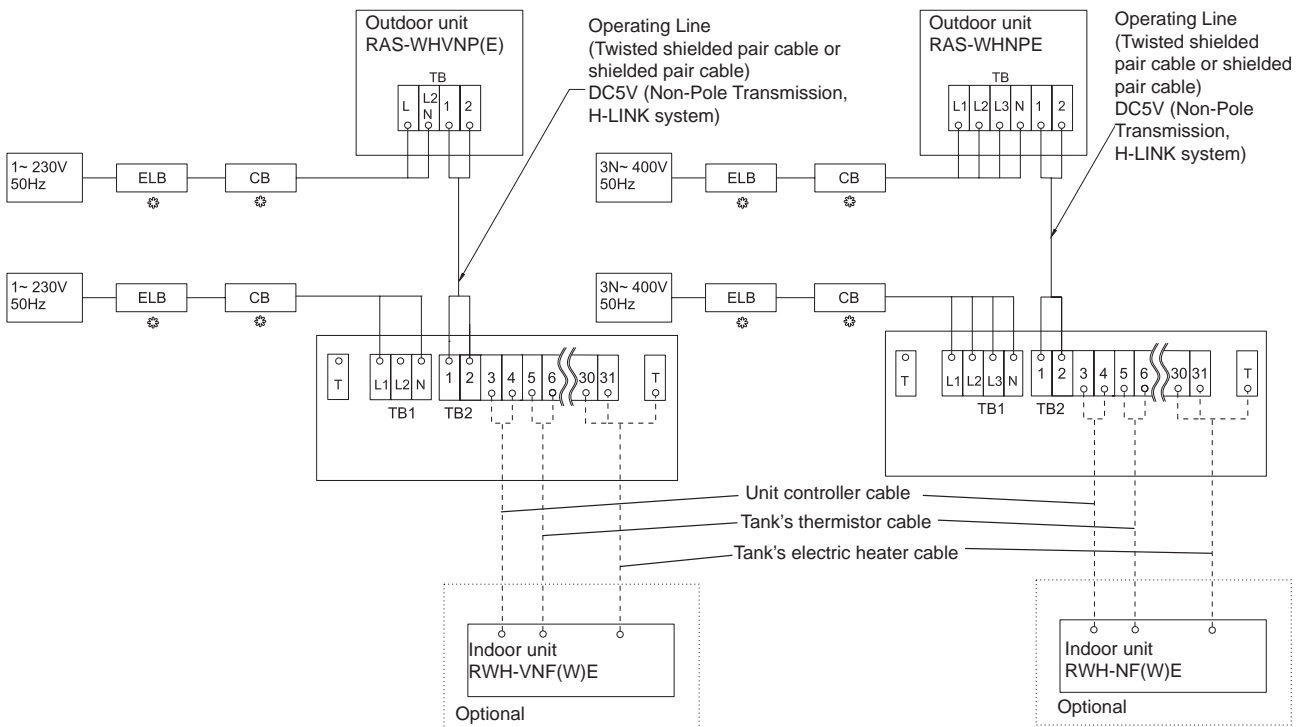

YUTAKI M

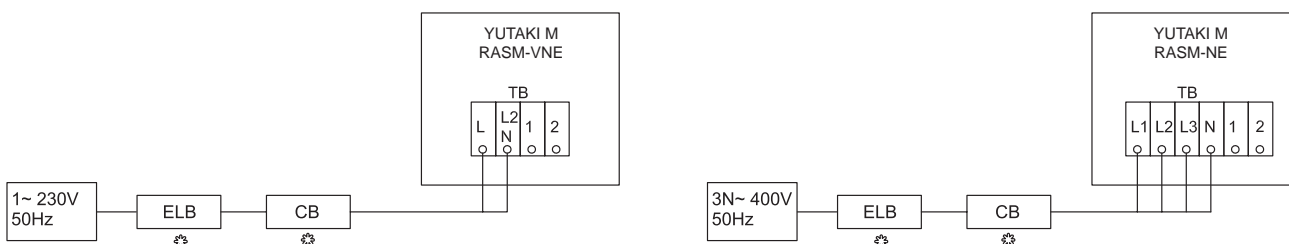

10.3 Electrical connection

CAUTION

- Check to ensure that the field supplied electrical components (mains power switches, circuit breakers, wires, connectors and wire terminals) have been properly selected according to the electrical data indicated on this chapter and they comply with national and local codes. If it is necessary, contact with your local authority in regards to standards, rules, regulations, etc.
- Use a dedicated power circuit for the indoor unit. Do not use a power circuit shared with the outdoor unit or any other appliance.

10.3.1 Wiring size

Use wires which are not lighter than the polychloroprene sheathed flexible cord (code designation 60245 IEC 57).

◆ Split system - Outdoor unit

Model	Power supply	Max. current (A)	Power supply cables	Transmitting cables	Actuator cables
			EN60335-1	EN60335-1	EN60335-1
RAS-2WHVNP	1~ 230V 50Hz	13.8	2 x 2.5 mm ² + GND	2 x 0.75 mm ² (*Shielded cable)	2 x 0.75 mm ² + GND
RAS-2.5WHVNP		15.8	2 x 4.0 mm ² + GND		
RAS-3WHVNP		17.8	2 x 4.0 mm ² + GND		
RAS-4WHVNPE		30.5	2 x 10.0 mm ² + GND		
RAS-5WHVNPE		30.5	2 x 10.0 mm ² + GND		
RAS-6WHVNPE		30.5	2 x 10.0 mm ² + GND		
RAS-4WHNPE	3N~ 400V 50Hz	14.0	4 x 4.0 mm ² + GND		
RAS-5WHNPE		14.0	4 x 4.0 mm ² + GND		
RAS-6WHNPE		16.0	4 x 4.0 mm ² + GND		
RAS-8WHNPE		24.0	4 x 6.0 mm ² + GND		
RAS-10WHNPE		24.0	4 x 6.0 mm ² + GND		

◆ Split system - Indoor unit

YUTAKI S

Model	Power supply	Operation mode	Max. current (A)	Power supply cables	Transmitting cables	Actuator cables
				EN60335-1	EN60335-1	EN60335-1
RWM-(2.0-3.0)NE	1~ 230V 50Hz	Without electric heaters	0.2	2 x 1.5 mm ² + GND	2 x 0.75 mm ²	2 x 0.75 mm ² + GND
		With electric heater	15.3	2 x 2.5 mm ² + GND		
		With DHW tank heater	15.3	2 x 2.5 mm ² + GND		
		With electric and DHW tank heaters	30.3	2 x 6.0 mm ² + GND		
RWM-(4.0-6.0)NE	1~ 230V 50Hz	Without electric heaters	0.3	2 x 1.5 mm ² + GND		
		With electric heater	30.5	2 x 6.0 mm ² + GND		
		With DHW tank heater	15.4	2 x 2.5 mm ² + GND		
		With electric and DHW tank heaters	45.5	2 x 10.0 mm ² + GND		
	3N~ 400V 50Hz	Without electric heaters	0.3	4 x 1.5 mm ² + GND		
		With electric heater	10.3	4 x 2.5 mm ² + GND		
		With DHW tank heater	15.4	4 x 4.0 mm ² + GND		
		With electric and DHW tank heaters	25.4	4 x 6.0 mm ² + GND		
RWM-(8.0/10.0)NE	3N~ 400V 50Hz	Without electric heaters	0.3	4 x 1.5 mm ² + GND		
		With electric heater	15.3	4 x 4.0 mm ² + GND		
		With DHW tank heater	15.4	4 x 4.0 mm ² + GND		
		With electric and DHW tank heaters	30.4	4 x 10.0 mm ² + GND		

NOTE

The data corresponding to DHW tank heater is calculated in combination with the domestic hot water tank accessory "DHWT-(200/300)S-3.0H2E".

YUTAKI S COMBI

Model	Power supply	Operation mode	Max. current (A)	Power supply cables	Transmitting cables	Actuator cables
				EN60335-1	EN60335-1	EN60335-1
RWD-(2.0-3.0) NW(S)E-(200/260) S-(K)	1~230V 50Hz	Without electric heaters	0.2	2 x 1.5 mm ² + GND	2 x 0.75 mm ²	2 x 0.75 mm ² + GND
		With electric heater	15.3	2 x 2.5 mm ² + GND		
		With DHW tank heater	14.5	2 x 2.5 mm ² + GND		
		With electric and DHW tank heaters	29.6	2 x 6.0 mm ² + GND		
RWD-(4.0-6.0) NW(S)E-(200/260) S-(K)	1~230V 50Hz	Without electric heaters	0.3	2 x 1.5 mm ² + GND		
		With electric heater	30.5	2 x 6.0 mm ² + GND		
		With DHW tank heater	14.7	2 x 2.5 mm ² + GND		
		With electric and DHW tank heaters	44.8	2 x 10.0 mm ² + GND		
	3N~400V 50Hz	Without electric heaters	0.3	4 x 1.5 mm ² + GND		
		With electric heater	10.3	4 x 2.5 mm ² + GND		
		With DHW tank heater	14.7	4 x 4.0 mm ² + GND		
		With electric and DHW tank heaters	24.7	4 x 6.0 mm ² + GND		

YUTAKI S80

Indoor unit alone

Model	Power supply	Operation mode	Max. current (A)	Power supply cables	Transmitting cables	Actuator cables	
				EN60335-1	EN60335-1	EN60335-1	
RWH-4.0VNF	1~ 230V 50Hz	Without DHW tank heater	24.0	2 x 6.0 mm ² + GND	2 x 0.75 mm ²	2 x 0.75 mm ² + GND	
		With DHW tank heater	38.0	2 x 10.0 mm ² + GND			
RWH-5.0VNF		Without DHW tank heater	28.0	2 x 6.0 mm ² + GND			
		With DHW tank heater	42.0	2 x 10.0 mm ² + GND			
RWH-6.0VNF		Without DHW tank heater	31.0	2 x 6.0 mm ² + GND			
		With DHW tank heater	45.0	2 x 10.0 mm ² + GND			
RWH-4.0NF		3N~ 400V 50Hz	Without DHW tank heater	10.0			4 x 2.5 mm ² + GND
			With DHW tank heater	24.0			4 x 4.0 mm ² + GND
RWH-5.0NF	Without DHW tank heater		10.0	4 x 2.5 mm ² + GND			
	With DHW tank heater		24.0	4 x 4.0 mm ² + GND			
RWH-6.0NF	Without DHW tank heater		10.0	4 x 2.5 mm ² + GND			
	With DHW tank heater		24.0	4 x 4.0 mm ² + GND			

Indoor unit in combination with DHW tank

Model	Power supply	Operation mode	Max. current (A)	Power supply cables	Transmitting cables	Actuator cables	
				EN60335-1	EN60335-1	EN60335-1	
RWH-4.0VNFWE	1~ 230V 50Hz	Without DHW tank heater	24.0	2 x 6.0 mm ² + GND	2 x 0.75 mm ²	2 x 0.75 mm ² + GND	
		With DHW tank heater	36.0	2 x 10.0 mm ² + GND			
RWH-5.0VNFWE		Without DHW tank heater	27.0	2 x 6.0 mm ² + GND			
		With DHW tank heater	40.0	2 x 10.0 mm ² + GND			
RWH-6.0VNFWE		Without DHW tank heater	31.0	2 x 10.0 mm ² + GND			
		With DHW tank heater	43.0	2 x 10.0 mm ² + GND			
RWH-4.0NFWE		3N~ 400V 50Hz	Without DHW tank heater	10.0			4 x 4.0 mm ² + GND
			With DHW tank heater	22.0			4 x 10.0 mm ² + GND
RWH-5.0NFWE	Without DHW tank heater		10.0	4 x 4.0 mm ² + GND			
	With DHW tank heater		22.0	4 x 10.0 mm ² + GND			
RWH-6.0NFWE	Without DHW tank heater		10.0	4 x 4.0 mm ² + GND			
	With DHW tank heater		22.0	4 x 10.0 mm ² + GND			

**NOTE**

The data corresponding to DHW tank heater is calculated in combination with the YUTAKI S80 domestic hot water tank accessory "DHWS(200/260)S-2.7H2E".

◆ Monobloc system - YUTAKI M

Model	Power supply	Operation mode	Max. current (A)	Power supply cables	Transmitting cables	Actuator cables
				EN60335-1	EN60335-1	EN60335-1
RASM-3VNE	1~ 230V 50Hz	Without DHW tank heater	18.0	2 x 4.0 mm ² + GND	2 x 0.75 mm ²	2 x 0.75 mm ² + GND
		With DHW tank heater	33.0	2 x 10.0 mm ² + GND		
RASM-4VNE		Without DHW tank heater	30.8	2 x 6.0 mm ² + GND		
		With DHW tank heater	45.8	2 x 10.0 mm ² + GND		
RASM-5VNE		Without DHW tank heater	30.8	2 x 6.0 mm ² + GND		
		With DHW tank heater	45.8	2 x 10.0 mm ² + GND		
RASM-6VNE		Without DHW tank heater	30.8	2 x 6.0 mm ² + GND		
		With DHW tank heater	45.8	2 x 10.0 mm ² + GND		
RASM-4NE	3N~ 400V 50Hz	Without DHW tank heater	14.3	4 x 4.0 mm ² + GND		
		With DHW tank heater	29.3	4 x 10.0 mm ² + GND		
RASM-5NE		Without DHW tank heater	14.3	4 x 4.0 mm ² + GND		
		With DHW tank heater	29.3	4 x 10.0 mm ² + GND		
RASM-6NE		Without DHW tank heater	24.3	4 x 6.0 mm ² + GND		
		With DHW tank heater	39.4	4 x 10.0 mm ² + GND		

**NOTE**

The data corresponding to DHW tank heater is calculated in combination with the domestic hot water tank accessory "DHWT-(200/300)S-3.0H2E".

10.3.2 Minimum requirements of the protection devices

⚠ CAUTION

- Ensure specifically that there is an Earth Leakage Breaker (ELB) installed for the units (outdoor and indoor unit).
- If the installation is already equipped with an Earth Leakage Breaker (ELB), ensure that its rated current is large enough to hold the current of the units (outdoor and indoor unit).

i NOTE

- Electric fuses can be used instead of magnetic Circuit Breakers (CB). In that case, select fuses with similar rated values as the CB.
- The Earth Leakage Breaker (ELB) mentioned on this manual is also commonly known as Residual Current Device (RCD) or Residual Current Circuit Breaker (RCCB).
- The Circuit Breakers (CB) are also known as Thermal-Magnetic Circuit Breakers or just Magnetic Circuit Breakers (MCB).

◆ Split system - Outdoor unit

Model	Power supply	Applicable voltage		MC (A)	CB (A)	ELB (no. of poles/A/mA)
		U max. (V)	U min. (V)			
RAS-2WHVNP	1~ 230V 50Hz	253	207	13.8	2.5	2/40/30
RAS-2.5WHVNP				15.8	4	
RAS-3WHVNP				17.8	4	
RAS-4WHVNP				30.5	10	
RAS-5WHVNP				30.5	10	
RAS-6WHVNP				30.5	10	
RAS-4WHNPE	3N~ 400V 50Hz	440	360	14.0	4	4/40/30
RAS-5WHNPE				14.0	4	
RAS-6WHNPE				16.0	4	
RAS-8WHNPE				24.0	6	
RAS-10WHNPE				24.0	6	

MC: Maximum current; CB: Circuit breaker; ELB: Earth leakage breaker

◆ Split system - Indoor unit

YUTAKI S

Model	Power supply	Applicable voltage		Operation mode	MC (A)	CB (A)	ELB (no. of poles/A/mA)
		U max. (V)	U min. (V)				
RWM-(2.0-3.0)NE	1~ 230V 50Hz	253	207	Without electric heaters	0.2	5	2/40/30
				With electric heater	15.3	16	
				With DHW tank heater	15.3	16	
				With electric and DHW tank heaters	30.3	32	
RWM-(4.0-6.0)NE	1~ 230V 50Hz	253	207	Without electric heaters	0.3	5	2/40/30
				With electric heater	30.5	32	
				With DHW tank heater	15.4	16	
				With electric and DHW tank heaters	45.5	63	
	3N~ 400V 50Hz	440	360	Without electric heaters	0.3	5	4/40/30
				With electric heater	10.3	15	
				With DHW tank heater	15.4	20	
With electric and DHW tank heaters	25.4	30					
RWM-(8.0/10.0)NE	3N~ 400V 50Hz	440	360	Without electric heaters	0.3	5	4/40/30
				With electric heater	15.3	20	
				With DHW tank heater	15.4	20	
				With electric and DHW tank heaters	30.4	40	

i NOTE

The data corresponding to DHW tank heater is calculated in combination with the domestic hot water tank accessory "DHWT-(200/300)S-3.0H2E".

YUTAKI S COMBI

Model	Power supply	Applicable voltage		Operation mode	MC (A)	CB (A)	ELB (no. of poles/A/mA)
		U max. (V)	U min. (V)				
RWD-(2.0-3.0) NW(S)E-(200/260)S(-K)	1~ 230V 50Hz	253	207	Without electric heaters	0.2	5	2/40/30
				With electric heater	15.3	16	
				With DHW tank heater	14.5	16	
				With electric and DHW tank heaters	29.6	32	
RWD-(4.0-6.0) NW(S)E-(200/260)S(-K)	1~ 230V 50Hz	253	207	Without electric heaters	0.3	5	2/40/30
				With electric heater	30.5	32	
				With DHW tank heater	14.7	16	
				With electric and DHW tank heaters	44.8	63	
	3N~ 400V 50Hz	440	360	Without electric heaters	0.3	5	4/40/30
				With electric heater	10.3	15	
				With DHW tank heater	14.7	20	
				With electric and DHW tank heaters	24.7	30	

YUTAKI S80

Version for indoor unit alone

Model	Power supply	Applicable voltage		Operation mode	MC (A)	CB (A)	ELB (no. of poles/A/mA)
		U max. (V)	U min. (V)				
RWH-4.0VNFE	1~ 230V 50Hz	253	207	Without DHW tank heater	24.0	32.0	2/40/30
RWH-5.0VNFE				With DHW tank heater	38.0	40.0	
				Without DHW tank heater	28.0	32.0	
RWH-6.0VNFE				With DHW tank heater	42.0	50.0	2/63/30
				Without DHW tank heater	31.0	32.0	2/40/30
With DHW tank heater				45.0	50.0	2/63/30	
RWH-4.0NFE	3N~ 400V 50Hz	440	360	Without DHW tank heater	10.0	15.0	4/40/30
RWH-5.0NFE				With DHW tank heater	24.0	25.0	
				Without DHW tank heater	10.0	15.0	
RWH-6.0NFE				With DHW tank heater	24.0	25.0	
				Without DHW tank heater	10.0	15.0	
With DHW tank heater				24.0	25.0		

Version for combination with DHW tank

Model	Power supply	Applicable voltage		Operation mode	MC (A)	CB (A)	ELB (no. of poles/A/mA)
		U max. (V)	U min. (V)				
RWH-4.0VNFWE	1~ 230V 50Hz	253	207	Without DHW tank heater	24.0	32.0	2/40/30
RWH-5.0VNFWE				With DHW tank heater	36.0	40.0	
				Without DHW tank heater	27.0	32.0	
RWH-6.0VNFWE				With DHW tank heater	40.0	50.0	2/63/30
				Without DHW tank heater	31.0	32.0	2/40/30
With DHW tank heater				43.0	50.0	2/63/30	
RWH-4.0NFWE	3N~ 400V 50Hz	440	360	Without DHW tank heater	10.0	15.0	4/40/30
RWH-5.0NFWE				With DHW tank heater	22.0	25.0	
				Without DHW tank heater	10.0	15.0	
RWH-6.0NFWE				With DHW tank heater	22.0	25.0	
				Without DHW tank heater	10.0	15.0	
With DHW tank heater				22.0	25.0		

**NOTE**

The data corresponding to DHW tank heater is calculated in combination with the YUTAKI S80 domestic hot water tank accessory "DHWS(200/260)S-2.7H2E".

◆ Monobloc system - YUTAKI M

Model	Power supply	Applicable voltage		Operation mode	MC (A)	CB (A)	ELB (no. of poles/A/mA)	
		U max. (V)	U min. (V)					
RASM-3VNE	1~ 230V 50Hz	253	207	Without DHW tank heater	18.0	20	2/40/30	
				With DHW tank heater	33.0	40		
RASM-4VNE				Without DHW tank heater	30.8	32	2/63/30	
				With DHW tank heater	45.8	63		
RASM-5VNE				Without DHW tank heater	30.8	32	2/40/30	
				With DHW tank heater	45.8	63	2/63/30	
RASM-6VNE	Without DHW tank heater	30.8	32	2/40/30				
	With DHW tank heater	45.8	63	2/63/30				
RASM-4NE	3N~ 400V 50Hz	440	360	Without DHW tank heater	14.3	20	4/40/30	
				With DHW tank heater	29.3	40		
RASM-5NE				Without DHW tank heater	14.3	20		4/40/30
				With DHW tank heater	29.3	40		
RASM-6NE				Without DHW tank heater	24.3	20		4/63/30
				With DHW tank heater	39.4	63		

**NOTE**

The data corresponding to DHW tank heater is calculated in combination with the domestic hot water tank accessory "DHWT-(200/300)S-3.0H2E".

10.4 Transmission wiring between outdoor and indoor unit

- The transmission is wired to terminals 1-2.
- The H-LINK II wiring system requires only two transmission cables that connect the indoor unit and the outdoor unit.

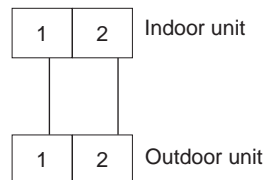

- Use twist pair wires (0.75 mm²) for operation wiring between outdoor unit and indoor unit. The wiring must consist of 2-core wires (Do not use wire with more than 3 cores).
- Use shielded wires for intermediate wiring to protect the units from noise interference, with a length of less than 300 m and a size in compliance with local codes.
- In the event that a conduit tube for field-wiring is not used, fix rubber bushes to the panel with adhesive.

**CAUTION**

Ensure that the transmission wiring is not wrongly connected to any live part that could be damaged the PCB.

**NOTE**

This section applies only to split systems (Outdoor unit + Indoor unit). It does not apply to YUTAKI M.

10.5 Optional indoor unit wiring (accessories)

◆ Summary of the terminal board connections

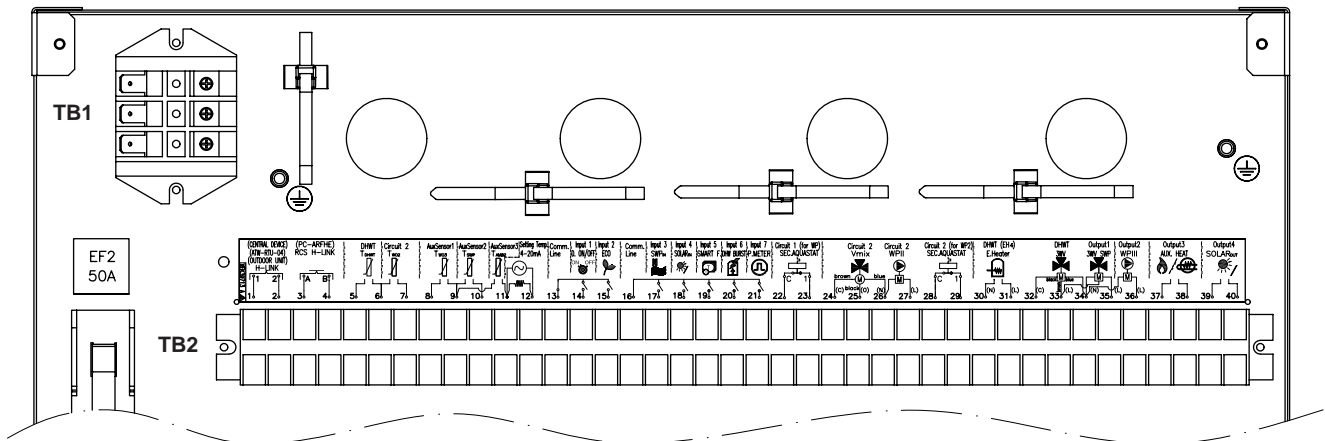

Mark	Part name	Description
TERMINAL BOARD 1 (TB1)		
N	1~ 230V	Main power supply connection
L1	50Hz	
L2	3N~ 400 50Hz	
L3	-	
TERMINAL BOARD 2 (TB2)		
1	H-LINK commutation	The H-LINK transmission has to be done between the indoor unit and the terminals 1-2 of either outdoor unit, ATW-RTU-04 or any other central device.
2		
3	H-LINK communication for remote control switch	PC-ARFHE
4		
5	DHW tank's thermistor	The DHW sensor is used to control the temperature of the domestic hot water tank
6	Common thermistor	Common terminal for thermistor
7	Thermistor for water outlet temperature of second cycle	The sensor is used for the second temperature control and should be positioned after the mixing valve and the circulation pump
8	Thermistor for water outlet temperature after hydraulic separator (As default: Aux Sensor 1)	Water sensor for hydraulic separator, buffer tank or boiler combination
9	Common thermistor	Common terminal for thermistors
10	Thermistor for swimming pool water temperature (As default: Aux Sensor 2)	The sensor is used for the swimming pool temperature control and should be positioned inside plate heat exchanger of the swimming pool
11	Thermistor for second ambient temperature (As default: Aux Sensor 3)	The sensor is used for the second ambient temperature control and it should be positioned outdoors
11	4-20 mA application	HSW and CSW operation can be overridden by external controller using 4~20mA input (CN5). In order to allow override operation a DSW setting must be done, otherwise values selected by 7-segments will be used. When override operation is allowed, external controller decides the target temperature by inputting a 4~20mA value current in CN5. This connector will transform input current to voltage by means of a grounded 240Ω resistor connected into a terminal board. Unit will convert read voltage to setting temperature proportionately.
12		
13	Common line	Terminal Line common for input 1 and input 2.
14	Input 1 (Demand ON/OFF) (*)	The air to water heat pump system has been designed to allow the connection of a remote thermostat to effectively control your home's temperature. Depending on the room temperature, the thermostat will turn the split air to water heat pump system ON and OFF.
15	Input 2 (ECO mode) (*)	Available signal which allows to reduce the water temperature setting of circuit 1, circuit 2 or both.
16	Common line	Terminal Line common for inputs 3, 4, 5, 6, 7.
17	Input 3 (Swimming pool) (*)	Only for swimming pool installations: It is necessary to connect an external input to the air to water heat pump to provide signal when the water pump of swimming pool is ON.
18	Input 4 (Solar) (*)	Available input for Solar combination with Domestic Hot Water Tank

Mark	Part name	Description
19	Input 5 (Smart function) (*)	This function allows an external tariff switch device to switch OFF the heat pump and/ or the DHW during peak electricity demand period. Depending on the setting, the heat pump and/ or DHW become blocked or only is switched ON the DHW when signal is open/closed.
20	Input 6 (DHW boost) (*)	Available input for an instantaneous heating of the domestic hot water of the tank
21	Input 7 (Power meter)	The measuring of the real power consumption can be done connecting an external power meter. The number of pulses of the power meter is a variable which must be set. By this, every pulse input is added into corresponding operation mode (Heating, Cooling, DHW Operation). Two possible options: - One power meter for all installation (IU+OU). - Two separated power meters (one for IU and one for OU).
22	Aquastat security for circuit 1 (WP1)	Terminals intended for the connection of the Aquastat security accessory (ATW-AQT-01) to control the water temperature of the circuit 1. Terminals for the connection of the limit thermostat (only for UK market models).
23	Limit thermostat(Only UK market models)	
24(C)	Mixing valve close	When a mixing system is required for a second temperature control, these outputs are necessary to control the mixing valve.
25(O)	Mixing valve open	
26(N)	N Common	
27(L)	Water Pump 2 (WP2)	When there is a second temperature application, a secondary pump is the circulating pump for the secondary heating circuit.
28	Aquastat security for circuit 2 (WP2)	Terminals intended for the connection of the Aquastat security accessory (ATW-AQT-01) to control the water temperature of the circuit 2.
29		
30(N)	Electrical Heater DHW Output	If DHW tank contains an electric heater, the air to water heat pump can activate it if the heat pump cannot achieve the required DHW temperature by itself.
31(L)		
32(C)	Common line	Common terminal for the 3-way valve for DHW tank
33(L)	3-way valve for DHW tank	The air to water heat pump can be used to heat DHW. This output will be on when DHW is activated.
34(N)	N common	Neutral terminal common for 3-way valve of DHW tank and outputs 1 and 2.
35(L)	Output 1 (3-way valve for swimming pool) (*)	The air to water heat pump can be use to heat swimming pool. This output will be ON when swimming pool is activated.
36(L)	Output 2 (Water pump 3 (WP3)) (*)	When there is a hydraulic separator or buffer tank, additional water pump (WP3) is needed.
37	Output 3 (Auxiliary boiler or electric heater) (*)	The boiler can be used to alternate with the heat pump when the heat pump cannot achieve the required temperature by itself.
38		A water electric heater (as accessory) can be used to provide the additional heating required on the coldest days of the year.
39	Output 4 (Solar) (*)	Output for solar combination with Domestic Hot Water Tank.
40		

**NOTE**

(*): Inputs and outputs explained in the table are the factory-set options. By means of the unit controller, some other inputs and outputs functions can be configured and used. Please, refer to the Service Manual for detailed information.

10.6 Setting of DIP switches and RSW switches

10.6.1 Outdoor unit

10.6.1.1 Location of DIP switches and rotary switches

The PCB in the outdoor unit is operating with DIP switches and push switches. The location is as follows:

RAS-(2/2.5/3)WHVNP

PCB1

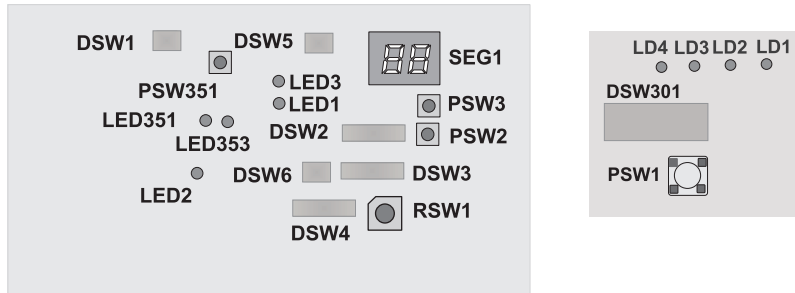

RAS-(4-10)WH(V)NPE and PCB1 for YUTAKI M (RASM-(3-6)(V) NE)

PCB

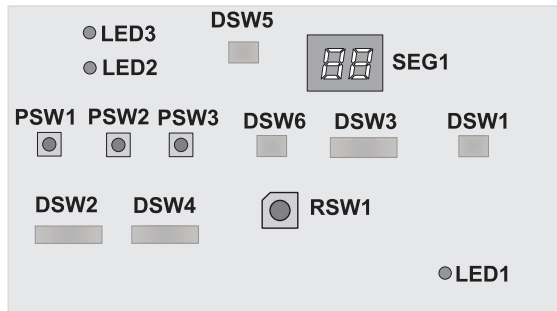

NOTE

DIP-IPM or PCB2 (depending on model) has a DSW1. When pin number 1 is set to ON position, the electrical current detections is cancelled. Pin number 1 should be to OFF position after electrical work.

10.6.1.2 Function of DIP switches and rotary switches



NOTE

- The mark “■” indicates the position of dips switches.
- No mark “■” indicates pin position is not affecting.
- The figures show the settings before shipment or after selection.



DANGER

Before setting dips switches, first turn the power source off and then set the position of the dips switches. In case of setting the switches without turning the power source off, the contents of the setting are invalid.

◆ DSW301 (Only RAS-(2/2.5/3)WHVNP): Test run mode

Setting before shipment	
Test run for pump down	
Test run for heating	
Forced stoppage of compressor	

◆ DSW1 (Only RAS-(2/2.5/3)WHVNP): No setting is required

When set pin number 1 to ON, the electric current detection is cancelled. Pin number 1 should be set back to OFF after electrical work	
--	--

◆ DSW1 (RAS-(4-10)WH(V)NPE) and PCB1 for YUTAKI M (RASM-(3-6)(V) NE): For Test run



Factory setting	
Test run for pump down	
Test run for heating	
Test run for cooling intermediate season	
Test run for heating for intermediate season	
Forced stoppage of compressor	



NOTE



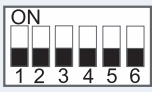

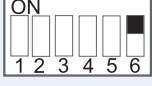





- This operation is reset once the compressor is in Thermo-ON mode.
- During the test run operation the units will operate continuously during 2 hours without Thermo-OFF and the 3-minute guard for compressor protection will be effective.
- Test run will start within 20 seconds after setting DSW1 pin 1 to ON position

◆ DSW2: selection function



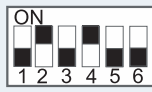

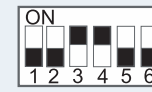
Setting before shipment	
Optional function setting mode (The optional function selection mode becomes available)	
External input/output setting mode (The output signals selection mode becomes available).	

◆ DSW3: Capacity setting (No setting is required)

Outdoor unit RAS-(2-10)WH(V)NPE Factory setting

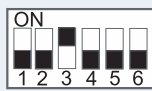
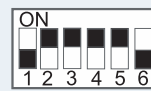
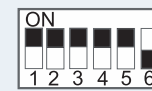
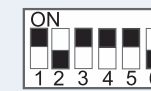
RAS-2WHVNP 	RAS-2.5WHVNP 	RAS-3WHVNP 	RAS-4WHVNP 	RAS-5WHVNP 	RAS-6WHVNP 
RAS-4WHNPE 	RAS-5WHNPE 	RAS-6WHNPE 	RAS-8WHNPE 	RAS-10WHNPE 	

YUTAKI M RASM-(3-6)(V) NE Factory setting

RASM-3VNE 	RASM-4VNE 	RASM-5VNE 	RASM-6VNE 
	RASM-4NE 	RASM-5NE 	RASM-6NE 

◆ DSW4 / RSW1: Refrigerant cycle number setting (No setting is required)

Setting before shipment		
-------------------------	---	--

◆ DSW5: End terminal resistance (No setting is required)

Setting before shipment	
-------------------------	---

◆ DSW6: Additional setting (No setting is required)

Setting before shipment	
-------------------------	---

10.6.1.3 LED indication

LED Indication		
LED1	Red	This LED indicates the transmission status between the indoor unit and the unit controller
LED2	Yellow	This LED indicates the transmission status between the indoor unit and the outdoor unit
LED3	Green	Power source for the PCB

10.6.2 YUTAKI unit

10.6.2.1 Location of DIP switches and rotary switches

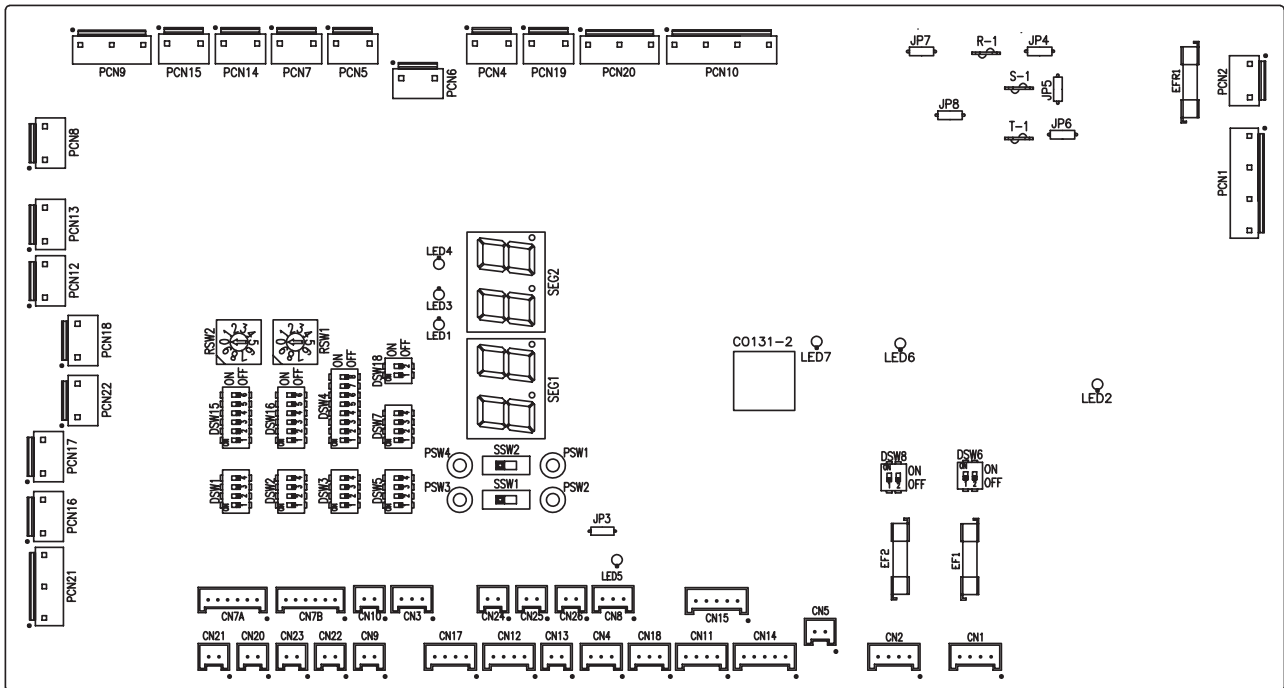

10.6.2.2 Function of DIP switches and rotary switches

i NOTE

- The mark “■” indicates the dip switches positions.
- No mark “■” indicates pin position is not affected.
- The figures show the settings before shipment or after selection.
- “Not used” means that the pin must not be changed. A malfunction might occur if changed.

! CAUTION

Before setting dip switches, first turn the power supply OFF and then set the position of dip switches. If the switches are set without turning the power supply OFF, the contents of the setting are invalid.

◆ DSW1: Additional setting 0

Factory setting. No setting is required.

YUTAKI S (*)		
YUTAKI S COMBI (*)		
YUTAKI S80	1~ 230V 50Hz	3N~ 400V 50Hz
YUTAKI M (*)		

i NOTE

(*): In case of installing the “Cooling kit” accessory, set the pin 4 of DSW1 to ON in order to enable the cooling operation.

◆ DSW2: Unit capacity setting

Factory setting. No setting is required.

2.0 HP	2.5 HP	3.0 HP	4.0 HP	5.0 HP	6.0 HP	8.0 HP	10.0 HP

◆ DSW3: Additional setting 1

Setting before shipment	
1-step heater for 3-phase unit	

◆ DSW4: Additional setting 2







Setting before shipment	
DHW defrost	
Heater forced OFF	
Unit and installation pipes antifreeze protection	
Standard / ECO water pump operation	
Electric heater or boiler emergency mode	
DHW tank's heater operation	
- Open SV1/2 for vacuum and R-410A refrigerant recovery function (YUTAKI S80) - DHW 3-way valve forced ON (All models)	
- Disabled R-134a compressor (YUTAKI S80) - Mirror function (YUTAKI M)	

⚠ CAUTION

- Never turn all DSW4 dip switch pins ON. If this happens, the software of the unit will be removed.
- Never activate "Heater Forced OFF" and "Electric heater or boiler emergency mode" at the same time.

◆ DSW5: Additional setting 3

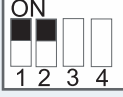
In the cases where the outdoor unit is installed into a location where its own outdoor ambient temperature sensor can not give a suitable temperature measurement to the system, it is available the 2nd outdoor ambient temperature sensor as accessory. By means of DSW1&2 setting, the preferable sensor for each circuit can be selected.

Factory setting	
Outdoor unit sensor for circuits 1 and 2.	
Outdoor unit sensor for circuit 1; Auxiliary sensor for circuit 2.	
Auxiliary sensor for circuit 1; Outdoor unit sensor for circuit 2.	
Auxiliary sensor instead of outdoor unit sensor for both circuits.	
4-20 mA setting temperature (Only manual operation)	
Use the maximum temperature value between Two3 (boiler / heater thermistor) and Two (water outlet thermistor) for water control	

◆ DSW6: Not used

Factory setting (Do not change)	
------------------------------------	---

◆ DSW7: Additional setting 4

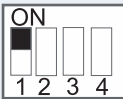



Factory setting	
Integrated DHW tank version (YUTAKI S80 only)	

◆ DSW8: Not used

Factory setting (Do not change)	
------------------------------------	---

◆ DSW18: Additional setting 5 (Capacity control function for YUTAKI S80 only)

This function allows the capacity control by modifying the start and stop conditions of the second cycle, depending on the heat load of the installation when the water temperature is low.

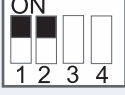
Factory setting	
Power start (Medium heat load at low water temperature)	
High power start (High heat load at low water temperature)	
Low power start (Low heat load at low water temperature)	
Very high power start (Very high heat load at low water temperature)	



◆ DSW15 & RSW2: Not used

Do not change.



◆ DSW16 & RSW1: Not used

Do not change.

◆ SSW1: Remote/Local

Factory setting Remote operation	Remote Local	
Local operation	Remote Local	

◆ SSW2: Heat/Cool (when SSW1 is in local setting)

Factory setting Heat operation	Heat Cool	
Cooling operation (when cooling kit installed)	Heat Cool	

10.6.2.3 LED indication

Name	Colour	Indication
LED1	Green	Power indication
LED2	Red	Power indication
LED3	Red	Heat pump operation (thermo ON/OFF)
LED4	Yellow	Alarm (flickering with 1 sec interval)
LED5	Green	Inverter transmission (YUTAKI S80 only)
LED6	Yellow	H-Link transmission
LED7	Yellow	H-Link transmission for unit controller

11 . Optional functions

Index

11.1	Indoor unit	238
11.1.1	Optional functions from unit controller	238
11.1.2	Optional functions from DIP-switch setting.....	239
11.1.3	Optional external input/output signals (by 7-segment display).....	241
11.2	Additional functions by accessory sensor	242
11.3	Change of defrost condition	243
11.4	Optional external output signals for outdoor units and YUTAKI M units.....	244

11.1 Indoor unit

11.1.1 Optional functions from unit controller

Optional function	Explanation	Model
Floor screed drying function (Circuits 1 & 2)	This function is used exclusively for the process of drying screed that has been newly applied to floor heating system. The water temperature set-point follows a predetermined schedule upon activation of the floor screed drying function (This process is based on EN 1264 part 4)..	A
Automatic summer switch-OFF	The system will switch OFF the heating mode when the daily average outdoor temperature of the previous day rises above a certain value at the summer switch-OFF activation temperature, to prevent heating operation at high outdoor temperatures.	A
Pump and motorized valve seizure protection	This function prevents sticking of components due to long periods of inactivity, by running the components during a short period every week.	A
Hydraulic separator combination	In some cases, water pump of the YUTAKI unit is not sized for big heating installation (small water pump). In this case, a hydraulic separator or buffer tank and secondary water pump has to be used to ensure proper water pump dimensioning. The boiler is configured in parallel with the heat pump. A hydraulic separator or buffer tank has to be used to ensure proper hydraulic balancing. Additional Water pump (WP3) and water sensor (Two3) are needed for boiler combination control (automatic added when Boiler combination is enabled)	A
Electrical heater or boiler emergency mode	For the use of the electrical heater or boiler in case of outdoor unit fault, additional setting shall be applied into IU setting: Electrical heater emergency can be both automatic or manual switched ON by the user and the configuration must be done from the Unit controller	A
Outdoor temperature average timer	The average timer corrects the influence of ambient temperature variations. The weather-dependent set point calculation is done on the average outdoor temperature. The outdoor temperature is averaged over the selected time period.	A
DHW anti-Legionella protection	A specific setting is available to protect the DHW system against Legionella, which raises up the DHW temperature over the normal DHW tank temperature setting (using the electric heater of the DHW tank and/or the heat pump) on a periodic basis.	A
Smart action	This function allows an external tariff switch device to switch OFF the heat pump and/or the DHW during peak electricity demand period. Depending on the setting, the heat pump and/or DHW become blocked or only is switched ON the DHW when signal is open/closed. When the system is working in combination with boiler, the boiler is switched ON to provide the necessary heating.	A
DHW re-circulation	This function allows the activation of the water pump for the re-circulation of the hot water from the DHW tank by means of the heat pump. This function can also be used with the anti-legionella protection function.	A
DHW boost	With this function enabled, it is possible to request a heating up of the DHW when user requires an instantaneous delivery of DHW.	A
Power meter data control	The measuring of the real power consumption can be done connecting an external power meter. The number of pulses of the power meter is a variable which must be set through the unit controller. By this, every pulse input is added into its corresponding operation mode (Heating, Cooling, DHW Operation). Two possible options: - One power meter for all installation (IU+OU). - Two separated power meters (one for IU and one for OU).	A
Stopping of the water pump mode	The water pump stop mode can be selected by means of the unit controller user's interface between two modes "Standard" mode or "Thermo-OFF" mode.	A



NOTE

- (A): All models
- (S): Only YUTAKI S models
- (SC): Only YUTAKI S COMBI models
- (S80): Only YUTAKI S 80 models
- (M): Only YUTAKI M models

11.1.2 Optional functions from DIP-switch setting

Optional function	Explanation	Model
Unit and installation pipes anti freeze protection (Winter operation)	In winter (heating operation), when the outdoor temperature is very low and the unit is in Thermo OFF operation (and water pump OFF), the water outlet temperature can become so low that the pipes become frozen. In order to avoid this, the water pump anti-freeze control function can be selected by dip-switch setting in order to start the pump operation when the water outlet temperature drops below 5°C and until it raises above 7°C. For YUTAKI M, there is an additional function in case that this function is not enabled. The anti freeze control heater of YUTAKI M unit always turns ON to protect the plate heat exchanger of the YUTAKI M from freezing when outdoor temperature lowers to 2°C or less, regardless of compressor operation/stop status. The anti freeze control heater turns OFF when the outlet water temperature is 15°C or higher, or when the outdoor temperature becomes 4°C or higher.	A
One step heater for three phase unbalance option	This option can be used to switch all 3 steps of the electric heater at the same time, by means of a DIP-switch setting, in order to prevent 3-phase imbalance by the electric heater steps.  NOTE <i>This function only applies when power source of the indoor unit is 3-phase (3N~ 400V 50Hz).</i>	A
2nd outdoor temperature sensor accessory	A 2nd outdoor ambient temperature sensor is available as an accessory, in case that the built-in ambient temperature sensor of the outdoor unit can not provide a reliable temperature measurement to the system because of restraints of the installation location. The preferred sensor for each circuit can be selected by means of DSW setting.	A
Heater forced OFF	This function forces a permanent OFF of the heater when selecting an installation configuration without the electric heater of the unit (Mono-valent system or Alternating bi-valent system (Only boiler)). In this case, all the uses of the electric heater are forbidden and the settings by unit controller and the heater protections have no effect.	A
Standard / ECO water pump operation	The pump is set to "Standard mode" by default. In this mode, the pump is always ON, except when space heating/cooling OFF is selected. It is possible to set the pump to "Economic Mode" by dip-switch setting, so the water pump can be stopped when heat demand by Thermostat (Room ambient temperature is reached) is not required or when the system is stopped.	A
DHW defrost	This function allows to perform the defrost operation at the DHW tank instead of at the indoor water installation.	A
Use the max. temperature value between Two3 (boiler/heater/buffer tank thermistor) and Two (water outlet thermistor) for water control	In some situations, for example in an installation with a big buffer tank in combination with a boiler, it is preferable to perform water control by external water temperature sensor (Two3) instead of water temperature sensor (Two). This option can be activated by dip-switch setting. Only available with universal sensor enabled).	A
Electric heater or boiler emergency mode	In the event of outdoor unit failure, the required heating can be provided by the electric heater or by the boiler, by means of DSW setting.	A
DHW 3-way valve forced ON	When combination with domestic hot water tank, the activation of this function changes the position of the 3-way valve to the DHW operation position, then the unit is forced to work against the heating coil of the DHW tank. This can be used, for example, for a quick water filling of the DHW tank's heating coil.	A
DHW tank's heater operation	The electric heater of the domestic hot water tank is disabled by factory setting. This function allows to activate its operation if needed.	A
4-20 mA setting temperature (Only manual operation)	HSW and CSW operation can be overridden by external controller using 4~20mA input (CN5). In order to allow override operation a DSW setting must be done, otherwise values selected by 7-segment will be used. When override operation is allowed, external controller decides the target temperature by inputting a 4~20mA value current in CN5. This connector will transform input current to voltage by means of a grounded 240Ω resistor connected into a terminal board. Unit will convert read voltage to setting temperature proportionately.	A
Open SV1/2 for vacuum and R-410A recovery function	In the process of vacuum and R-410A recovery of YUTAKI S80 it is very important to supply power to the indoor unit and to activate this function by DSW setting. Thereby, solenoid valves SV1 and SV2 of the indoor unit are opened to allow the operation of vacuum and refrigerant charge inside the indoor unit. It is very important to bring the DSW back to its original position when finishing the whole procedure.	S80
Disabled R-134a compressor	This function disables the compressor for the 2nd cycle (R-134a compressor), so that the unit is forced to operate at medium/low outlet water temperatures (Disabled cascade cycle)	S80
Mirror function	This function activates the communication between YUTAKI M PCB and the PCB of the dedicated accessory for mirror function.	M

Optional function	Explanation	Model
Capacity control function	This function allows the capacity control by modifying the start and stop conditions of the second cycle, depending on the heat load of the installation when the water temperature is low.	S80
Remote/Local operation	This function allows the control from the YUTAKI PCB the working mode. (In manual operation by seven segments configuration or using PC-ARFHE Controller)	A

**NOTE**

- (A): All models
- (S): Only YUTAKI S models
- (SC): Only YUTAKI S COMBI models
- (S80): Only YUTAKI S 80 models
- (M): Only YUTAKI M models

For the detailed information about optional functions, please refer to the Service Manual.

11.1.3 Optional external input/output signals (by 7-segment display)

The system has 7 input and 4 output optional signals (+ 4 output signals when using accessory). The new YUTAKI series allow different ports to be configured for those I/O signals, as well.

The user can configure those input signal to perform different functions from the unit controller. This is briefly explained in the next tables:

Input signals and input ports

Code	Name	Port
1	Input 1	PCN20 #1-5
2	Input 2	PCN20 #1-3
3	Input 3	PCN10 #1-9
4	Input 4	PCN10 #1-5
5	Input 5	PCN10 #1-3
6	Input 6	PCN6 #1
7	Input 7	PCN19 #1

Input functions. (To be configured from the unit controller):

Function #	Input	Description
0	Disabled	-
1	Demand ON/OFF	Send Demand ON or OFF Operation to Circuit 1 and Circuit 2
2	Smart Act.	This function must be used to block or limit the heat pump when restricted by Electric company. It allows an external Smart switch device to switch off or reduce consumption of the heat pump during time of peak electricity demand.
3	Swimming pool	When YUTAKI model is used to warm th swimming pool water, this input is used as a feedback for swimming pool water pump.
4	Solar	In case of combine YUTAKI with solar panels, this input is used as a feedback for solar station ready operation.
5	Operation mode	Cool/Heat must be changed by an input of an external contact signal. Contact signal is edge detection; Cool/Heat changeover by unit controller is also available
6	DHW boost	With this function enabled, it is possible to request a heating up of the DHW when user requires an instantaneous delivery of DHW.
7	Power meter 1	Input used as kW/h pulse count for Energy data recording
8	Demand ON/OFF C1	Send Demand ON or OFF Operation only to Circuit 1
9	Demand ON/OFF C2	Send Demand ON or OFF Operation only to Circuit 2
10	Forced heating	Forced Heating Demand by input of contact signal from outside
11	Forced cooling	Forced Cooling Demand by input of contact signal from outside
12	Power meter 2	Input used as kW/h pulse count for Energy data recording
13	ECO mode C1 & C2	Water temperature setting for Circuit 1 and Circuit 2 it is reduced by ECO operation mode (Default 3°C) by input of contact signal from outside
14	ECO mode C1	Water temperature setting for Circuit 1 it is reduced by ECO operation mode (Default 3°C) by input of contact signal from outside
15	ECO mode C2	Water temperature setting for Circuit 2 it is reduced by ECO operation mode (Default 3°C) by input of contact signal from outside
16	Force OFF	Force OFF operation for unit. RCS will continue as normally set but will show indication that operation is forbidden

Output signals and output ports

Code	Name	Port	
01	Output 1	PCN21 #3-5	230V
02	Output 2	PCN21 #1-5	230V
03	Output 3	PCN22 #1-3	Free voltage
04	Output 4	PCN18 #1-3	Free voltage
05	Output 5	CN20 #1-2	24Vdc
06	Output 6	CN21 #1-2	24Vdc
07	Output 7	CN22 #1-2	24Vdc
08	Output 8	CN23 #1-2	24Vdc

Output functions. (To be configured from the unit controller):

Function #	Output	Description
0	Disabled	
1	3WV SWP	In case of combine YUTAKI with swimming pool, this output is used to drive 3 way valve swimming pools.
2	WP3	In case of combine YUTAKI with boiler or hydraulic separator, this output is used to drive water pump 3.
3	Boiler combination	In case of combine YUTAKI with boiler, this output is used to switch ON it.
4	Solar pump	In case of combine YUTAKI with solar panel, this output is used to drive water pump station
5	Alarm signal	Output when an "Alarm Code" is received from Indoor Unit or outdoor unit.
6	Operation signal	Output in case that "Thermo ON" signal in any condition
7	Cooling signal	Output in case that "Thermo ON" signal in Cooling operation
8	Demand-ON signal circuit 1	Signal is enabled when circuit 1 is operating in Demand-ON
9	Heating signal	Output in case that "Thermo ON" signal in Heating operation
10	DHW signal	Output in case that "Thermo ON" signal in DHW operation
11	Defrost	Output if the operation state (STUNT) of the outdoor unit is defrosting.
12	DHW re-circulation pump	In case of re-circulation pump enabled for HSW tank
13	Heater combination (S80/M) relay 1	In case of Heater operation for YUTAKI S80 or YUTAKI M. Output for Relay 1.
14	Heater combination (S80/M) relay 2	In case of Heater operation for YUTAKI S80 or YUTAKI M. Output for Relay 2.

11.2 Additional functions by accessory sensor

HITACHI offers to its users the option to add more functions to the inputs from signals coming from some specific sensors. The configuration for this purpose is explained below:

I/O Terminal name		Port for setting (Connector number)	Factory default setting		Input/Output type
I/O	Display		Setting contents	Function #	
Sensor 1	R1	CN26 #2	Disabled	0	NTC
Sensor 2	R2	CN25 #1-2	Disabled	0	NTC
Sensor 3	R3	CN5 #1	Disabled	0	NTC

Function of sensors

Function #	Input	Description
1	Boiler combination/ Two3	This sensor is used in case to combine any YUTAKI model with an external boiler (and in case to combine a YUTAKI S80 with an electrical heater)
2	Swimming pool	When combining YUTAKI with swimming pool, this sensor is used to read the temperature from the water of the swimming pool.
3	Solar panel sensor	When combining YUTAKI with solar panels, this sensor is used to read the temperature from the solar panel.
4	Zone 1 & 2 ambient sensor	When the sensor is used (unit controller configuration enabled), ambient temperature sensor is carried out by this sensor and the ambient temperature setting received by unit controller or central platform. Value of sensor is applied to both circuits.
5	Zone 1 ambient sensor	When the sensor is used (unit controller configuration enabled), ambient temperature sensor is carried out by this sensor and the ambient temperature setting received by unit controller or central platform. Value of sensor is applied to circuit 1.
6	Zone 2 ambient sensor	When the sensor is used (unit controller configuration enabled), ambient temperature sensor is carried out by this sensor and the ambient temperature setting received by unit controller or central platform. Value of sensor is applied to circuit 2.
7	Second outdoor ambient	An outside temperature sensor can be directly connected to the controller in case the heat pump is located in a position not suitable for this measurement.

11.3 Change of defrost condition

These optional function is available for being selected using the PSW switches and 7-segment on the PCB of the Outdoor Units and YUTAKI M unit PCB:

Indication	Input signal	Application
⌘	Change of defrost condition	This function allows to shift the temperature conditions in order to cause an earlier defrosting. It is useful in installations placed in very cold regions, where frost generates continuously; enabling an earlier defrosting operation results in a lower amount of accumulated frost, therefore keeping higher heating capacity values.

Press "PSW1" and select the setting condition "1" at the change of defrost condition "⌘".

Example for RAS-(4-10)WH(V)NPE and PCB1 for YUTAKI M (RASM-(3-6)(V) NE)

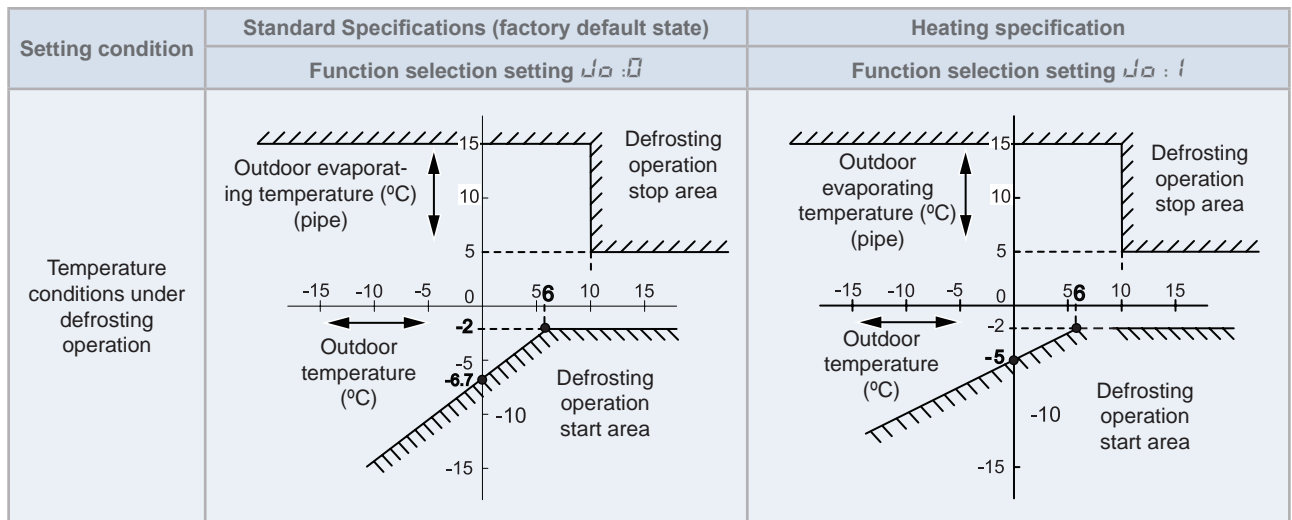

Example for RAS-(2/2.5/3)WHVNP

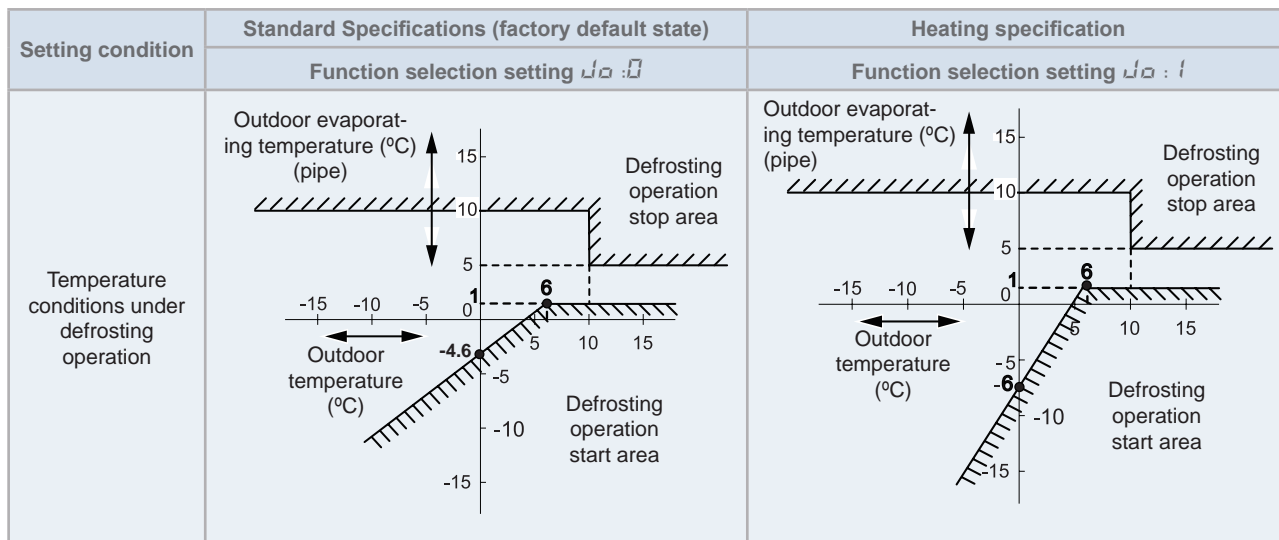

11.4 Optional external output signals for outdoor units and YUTAKI M units

◆ Output signals through 7-segment display on the unit PCB

The system has several output signals, which can be selected using the following connectors of the outdoor unit and YUTAKI M PCB:

- Output connector CN7, which has two ports to configure two optional output signals.

The selection of these output signals represents the selection of some optional functions programmed in the PCB of the RAS unit through the 7-segment display.

i NOTE

- Do not set same function to multiple output ports. If set, the setting of the higher output number is cleared to $\square\square$.
- Please refer to the Service Manual for detailed information of optional external input and output signals.

◆ Output signals on outdoor units and YUTAKI M units

Indication	Output signal	Application
$\square\square$	No setting application	No setting.
1	Operation signal	This signal allows to notify that the unit is operating. It enables to start up additional systems such as humidifiers, fans and other additional air-conditioning systems.
2	Alarm signal	This signal allows to notify that protection devices have been activated and to transfer it to additional systems.
3	Compressor ON signal	This signal allows to notify that the compressor is activated. This function can be applied for situations such as checking signals during remote-control operation and for the interlock of the RAS unit.
4	Defrost operation signal	This signal allows to notify that the unit is under defrosting operation.

Hitachi Air Conditioning Products Europe, S.A.U.
Ronda Shimizu, 1 - Políg. Ind. Can Torrella
08233 Vacarisses (Barcelona) Spain



Hitachi certifies that our products have met EU consumer safety, health and environmental requirements.



Hitachi Air Conditioning Products Europe, S.A.U. is certified with:
ISO 9001 of AENOR, Spain for its Quality Management accordance with the standard
ISO 14001 of AENOR Spain for its Environmental Management systems accordance with the standard.



Hitachi air conditioning products are manufactured according to:
ISO 9001 of JQA, Japan for its Quality Management accordance with the standard
ISO 14001 of JACO, Japan for its Environmental Management accordance with the standard.



Hitachi fulfills with the Certification NF-PAC that recognize the quality requirements for these heat pumps systems.



HITACHI participates in the Eurovent Certification Programme; the certified data of certified models are listed in the Eurovent Certification Online Directory (www.eurovent-certification.com).