



Providing sustainable energy solutions worldwide

Installation and Maintenance Manual

## **CTC EcoAir 600M**

Model 610M / 614M / 622M

Modulating air-to-water heat pump

400V 3N~

### **Important!**

- Read carefully before use, keep for future reference.
- Translation of the original instructions.





Installation and Maintenance Manual

## **CTC EcoAir 600M**

Modulating air-to-water heat pump

400V 3N~



## Table of Contents

<b>The Complete System</b> .....	<b>5</b>	<b>6. Electrical installation</b> .....	<b>22</b>
<b>1. Important to remember!</b> .....	<b>6</b>	6.1 General information, electrical connections .....	22
1.1 Transportation .....	6	6.2 Electric installation 400V 3N~ .....	22
1.2 Positioning .....	6	6.3 Compressor heater .....	22
1.3 Recycling .....	6	6.4 Heat pump connections .....	22
1.4 After commissioning .....	6	6.5 Series connection of the CTC EcoAir 600M .....	23
<b>Safety instructions</b> .....	<b>7</b>	6.5.1 Series connected heat pump connections .....	23
<b>Checklist</b> .....	<b>8</b>	6.6 Communication connection .....	25
<b>2. Connection option CTC EcoAir 600M</b> .....	<b>9</b>	6.6.1 Connection options for <u>one</u> heat pump .....	25
<b>3. Technical data</b> .....	<b>10</b>	6.7 Alarm output .....	25
3.1 Dimensions diagram .....	11	6.8 Connecting the control system .....	26
3.2 Component location .....	12	6.8.1 Define number of heat pumps .....	26
3.3 Refrigerant system .....	14	6.8.2 Numbering CTC EcoPart 600M to VP2 .....	26
3.4 Operating range .....	14	6.8.3 Worth knowing when addressing .....	28
<b>4. Installation</b> .....	<b>15</b>	6.8.4 Numbering CTC EcoPart 600M as A2 .....	29
4.1 Delivery includes: .....	15	6.9 Wiring diagram 400V 3N~ (A3) .....	32
4.2 Location of the heat pump .....	16	6.10 Wiring diagram 400V 3N~ (A4) .....	34
4.3 Preparation and drainage .....	17	6.11 Parts list .....	35
4.4 Condensation water .....	18	6.12 Sensor Data .....	36
<b>5. Pipe installation</b> .....	<b>19</b>	<b>7. First start</b> .....	<b>37</b>
5.1 Pipe connection .....	19	<b>8. Operation and Maintenance</b> .....	<b>37</b>
5.2 Example of connection to CTC EcoZenith i255 L .....	20	<b>9. Troubleshooting/Appropriate measures</b> .....	<b>39</b>
5.3 Circulating pump – heat carrier .....	20		
5.4 Pressure differential diagram for CTC EcoAir 600M .....	21		

# The Complete System



## CTC EcoAir 610M / 614M / 622M

CTC EcoAir 600M (610M / 614M / 622M) is a modulating air source heat pump which transfers heat from the outside air to the property's existing heating circuit. The heat pump works with outside air temperatures as low as -22 °C.

The CTC EcoAir 600M has been designed to operate with high efficiency and low noise levels. The heat pump has integrated, on-demand hot gas defrosting which keeps the evaporator coil free from ice in order to maintain high efficiency.

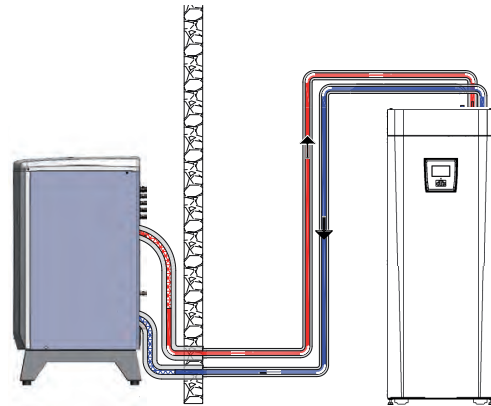

## Control

CTC EcoAir 600M is controlled by these products.

- CTC EcoZenith i550/555 Pro (CTC EcoAir 614M and 622M)
- CTC EcoLogic M/L/Pro/Family
- CTC EcoZenith i250/i255
- CTC EcoZenith i350/i360
- CTC EcoVent i350F/i360F

All control products must have program version 06/04/2018 or later.

## Charge pumps

CTC's PWM-controlled charge pumps are included with the products CTC EcoZenith i250/ i255 / i350 /i360 and CTC EcoVent i350F / i360F, and are available as accessories for CTC EcoZenith i550/i555 Pro and CTC EcoLogic.

Energy labels and data sheets can be downloaded from [www.ctc-heating.com/ecodesign](http://www.ctc-heating.com/ecodesign).

# 1. Important to remember!

Check the following points in particular at the time of delivery and installation:

## 1.1 Transportation

- Transport the heat pump to the installation location before removing the packaging. Move the product using one of the following means:
  - Forklift
  - Lifting band around the pallet. NB: Can only be used with the packaging on.
- The heat pump must be transported and stored upright.

## 1.2 Positioning

- The heat pump must be transported and stored upright.
- Remove the packaging and check before installation that the product has not been damaged in transit. Report any transport damage to the carrier.
- Place the product on a solid foundation, preferably concrete.
 

If the heat pump needs to be placed on a soft carpet, base plates must be placed under the adjustable feet.
- Remember to leave an access and service area of at least 1 metre in front of the heat pump.
- The heat pump must not be placed below floor level.
- Avoid placing the heat pump in rooms where the walls are of lightweight design, as people in the adjoining room may be disturbed by the compressor and vibrations.

**When contacting CTC, always mention the following:**

- Serial number
- Model/Size
- the fault message shown in the display
- Your telephone number

## 1.3 Recycling

- The packaging must be deposited at a recycling station or with the installation engineer for correct waste management.
- Obsolete products must be disposed of correctly and transported to a waste station or distributor/retailer offering this service. Disposal of the product as household waste is not permitted.
- It is very important that the product's refrigerant, compressor oil and electric/electronic components are disposed of correctly.

## 1.4 After commissioning

- The installation engineer advises the property owner on the design and servicing of the system.
- The installation engineer fills in a checklist and contact information – the customer and installation engineer sign the list, which the customer keeps.
- Register the product for warranty and insurance via the website: <https://www.ctc-heating.com/customer-service#warranty-registration>



Information in this type of box [i] is intended to help ensure that the product functions optimally.



Information in this type of box [!] is particularly important for correctly installing and using the product.

## For your own reference

Fill in the information below. It may come in useful if anything should happen.

Product:	Serial number:
Installer:	Name:
Date:	Tel. no.:
Electrical installer:	Name:
Date:	Tel. no.:

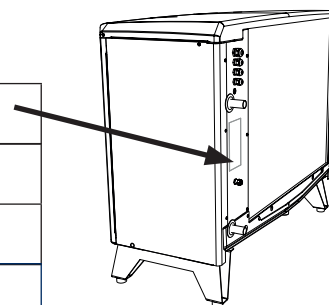

No liability is accepted for any misprints. We reserve the right to make design changes.

# Safety instructions



Turn off the power with an omnipolar switch before doing any work on the product.



The product must be connected to protective earth.



The product is classified as IP X4.



When handling the product with a hoist ring or similar device, make sure that the lifting equipment, eyebolts and other parts are not damaged. Never stand under the hoisted product.



Never jeopardise safety by removing bolted covers, hoods or similar.



Never jeopardise safety by deactivating safety equipment.



Any work on the product's cooling system should be carried out by authorised personnel only.



The product's electrical systems should only be installed and serviced by a qualified electrician.

-If the supply cord is damaged, it must be replaced by the manufacturer, its service agent or similarly qualified persons in order to avoid a hazard.



This device can be used by children from the age of eight years and above and by people with reduced physical, sensory or mental ability or lack of experience or knowledge if they have been taught, either with supervision or with the instructions provided, how to use the device safely and understand the risks involved. Children should not play with the device. Cleaning and maintenance should not be carried out by children without supervision.



If these instructions are not followed when installing, operating and maintaining the system, Enertech's commitment under the applicable warranty terms is not binding.

# Checklist

## The checklist must always be completed by the installation engineer

- If a service is performed, you may be required to provide this document.
- Installation must always be done according to the installation and maintenance instructions.
- Installation must always be carried out in a professional manner.

## Following installation, the unit must be inspected and functional checks performed as indicated below:

### Pipe installation

- Heat pump filled, positioned and adjusted in the correct manner according to the instructions.
- The heat pump is positioned so that it can be serviced.
- Capacity of the charge/radiator pump (depending on type of system) for the flow required.
- Make sure there is flow.
- Open radiator valves (depending on type of system) and other relevant valves.
- Tightness test.
- Bleed the system.
- Check proper operation of the requisite safety valves.
- Action taken to deal with condensation water.

### Electrical installation

- Safety switch.
- Correct and taut wiring.
- Requisite sensors fitted.
- Heat pump activated and started.
- Accessories.

### Customer information (adapted to the relevant installation)

- Start-up with customer/installer.
- Menus/controls for selected system.
- Installation and Maintenance Manual handed over to the customer.
- Check and filling, heating circuit.
- Information on fine adjustments.
- Alarm information.
- Functional test of safety valves fitted.
- Register your Installation Certificate at [ctc.se](http://ctc.se). ([ctc-heating.com](http://ctc-heating.com)).
- Information on fault reporting procedures.

\_\_\_\_\_  
Date/Customer

\_\_\_\_\_  
Date/Installer

## 2. Connection option CTC EcoAir 600M

The illustration below shows the different connection options available for the CTC EcoAir 600M.

In some cases, a CTC Converter or CTC Basic display may be needed. See the chapter on “Connecting the control system”.

The CTC EcoAir 600 can be connected to the products below:



CTC EcoLogic Pro/Family



CTC EcoLogic M, L

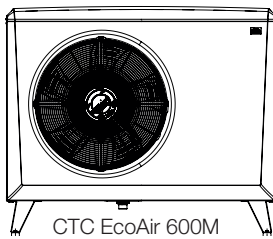

CTC EcoAir 600M

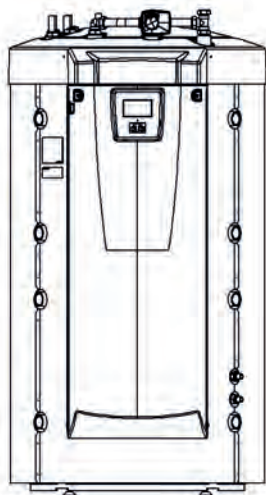

CTC EcoZenith i555 Pro  
CTC EcoZenith i550 Pro  
(NB: CTC EcoAir 610 is not compatible with CTC EcoZenith i550/555)

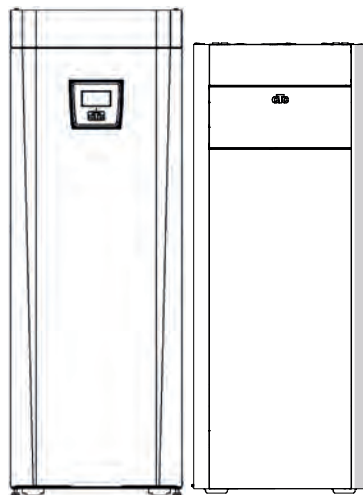

CTC EcoZenith i255  
CTC EcoZenith i360  
CTC EcoZenith i250  
CTC EcoZenith i350

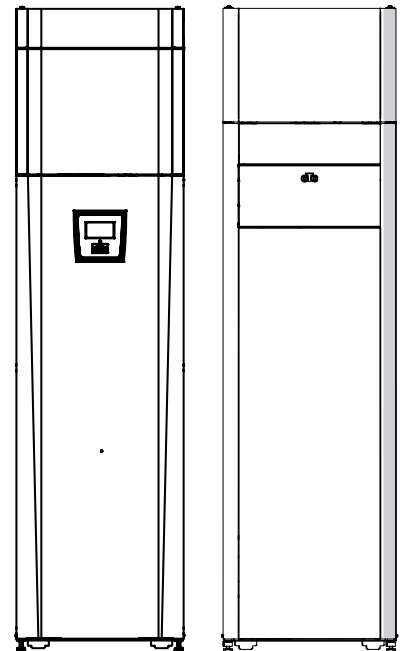

CTC EcoVent i360F  
CTC EcoVent i350F

**!** CTC EcoZenith i250, i255, i350, i360 and CTC EcoVent i350F/i360F can be connected to products with an output of up to 11 kW.

**!** Control products must have program version (or later):

CTC EcoZenith i550 Pro:	08/04/2018
CTC EcoZenith i555 Pro:	01/07/2020
CTC EcoLogic Pro/Family:	01/08/2019
CTC EcoLogic M, L:	01/07/2020
CTC EcoZenith i360:	01/07/2020
CTC EcoVent i360F:	07/07/2020

## 3. Technical data

		EcoAir 610M	EcoAir 614M	EcoAir 622M
CTC no.:		588402001	588400001	588401001
Electrical data		400 V 3N~ 50Hz	400 V 3N~ 50Hz	400 V 3N~ 50Hz
Input power <sup>1)</sup>	kW	0.54 / 2.20	0.54 / 3.94	0.94 / 6.03
Output power <sup>1)</sup>	kW	2.55 / 6.20	2.55 / 8.69	4.75 / 13.99
COP <sup>1)</sup>		4.71 / 2.82	4.71 / 2.21	5.07 / 2.32
Rated current <sup>2)</sup>	A	7.1	10.2	16.9
Rated current with temp. limit.	A	6.6	9.4	15.5
Max start current	A	2.7	2.7	4.9
Maximum permitted impedance at connection*	Ω	-	-	0.12
Water volume	liter	1.9	1.9	2.8
Refrigerant quantity R407C, fluorinated greenhouse gases GWP 1774 <sup>3)</sup>	kg	2.2	2.2	2.7
CO <sub>2</sub> equivalent	ton	3.903	3.903	4.790
Max/min system temperature	°C	65/15	65/15	65/15
Max/min system pressure	MPa (bar)	0.25/0.05 (2,5/0,5)	0.25/0.05 (2,5/0,5)	0.25/0.05 (2,5/0,5)
High pressure switch HT	MPa (bar)	3.1 (31)	3.1 (31)	3.1 (31)
Max/min temp. (TS) (PED)	°C	100/0	100/0	100/0
Max/min pressure (PS) (PED)	MPa (bar)	0.3/0 (3.0/0)	0.3/0 (3.0/0)	0.3/0 (3.0/0)
Dimensions (Depth x Width x Height)	mm	545 x 1245 x 1080	545 x 1245 x 1080	610 x 1375 x 1180
Compressor / Oil type		Inverter scroll / PVE FV50S	Inverter scroll / PVE FV50S	Inverter scroll / PVE FV50S
Air flow 100%	m <sup>3</sup> /h	3129	3129	5457
Fan speed	rpm	Modulating		
Fan, max power	W	54	54	148
Weight (packaged weight)	kg	174 (204)	174 (204)	192 (226)
Sound power in accord. w. ecodesign <sup>3)</sup>	dB (A)	53/53	51/52	55/55
Sound power Silent Mode <sup>4)</sup>	dB (A)	53	53	53
Ingress Protection (IP)		IP X4	IP X4	IP X4
Heat pump Certificate No.		012-SC0516-18	012-SC0319-18	012-SC0320-18

<sup>1)</sup> At 35°C water temperature. +7 @ min rps / -7 °C @ max rps. According to EN 14511.

<sup>2)</sup> At max rps incl. Grundfos UPM GEO 25-85 charge pump.

<sup>3)</sup> Sound power level in accordance with EN12102 appendix A.4 i at test conditions A7 W47/55 and A7 W30/35.

\*Maximum permitted impedance at the mains connection according to EN 61000-3-12. If the impedance at the mains connection is higher than the specified, check with the grid owner before purchasing the equipment.

<sup>4)</sup> Silent Mode requires software version 191128 or higher and is available in combination with CTC EcoLogic (software version 191203 or higher). Active silent mode reduces heating performance and efficiency.

No annual leakage control of the refrigerant is required.



Note: In case of deviations, the product's data plate applies. When servicing always check the product's data plate for correct refrigerant quantity.

### Noise data

	Sound power	Sound pressure 5 m	Sound pressure 10 m
EcoAir 610M	53/53 dB(A)	34/34 dB(A)	28/28 dB(A)
EcoAir 614M	51/52 dB(A)	32/33 dB(A)	26/27 dB(A)
EcoAir 622M	55/55 dB(A)	36/36 dB(A)	30/30 dB(A)

The stated sound values should be considered an indication only, as the level is affected both by power output and the surroundings

### 3.1 Dimensions diagram

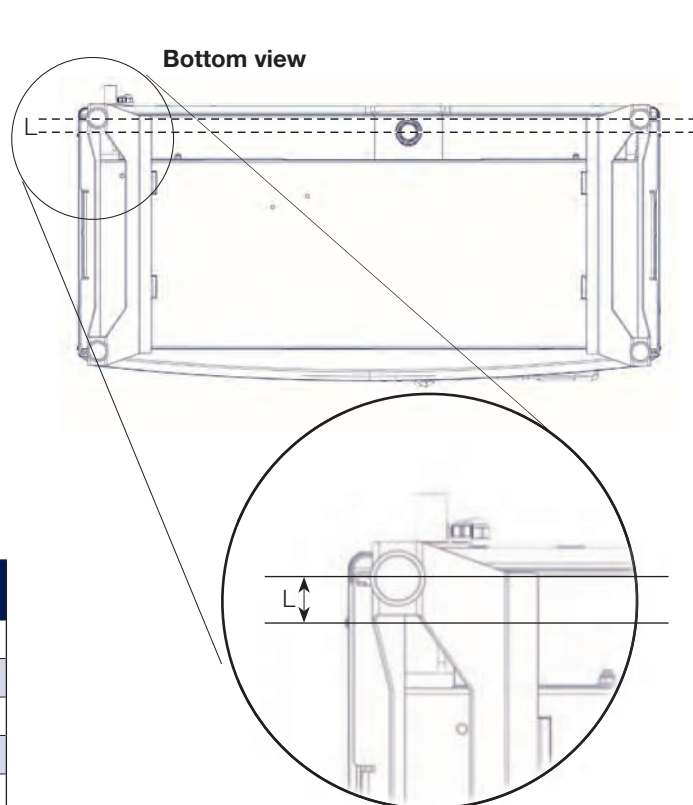
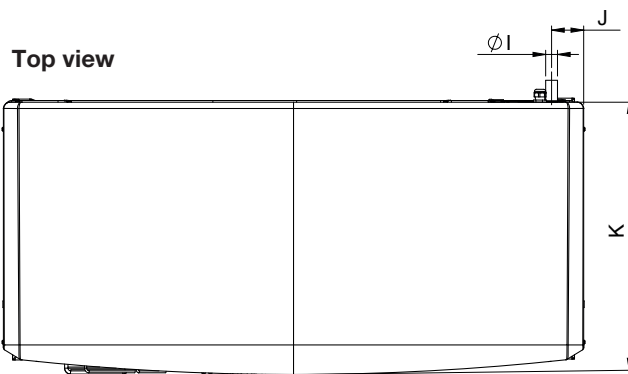
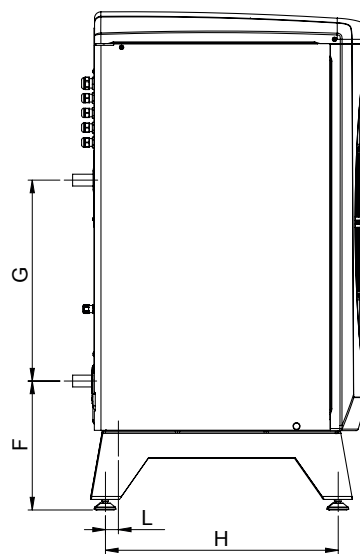
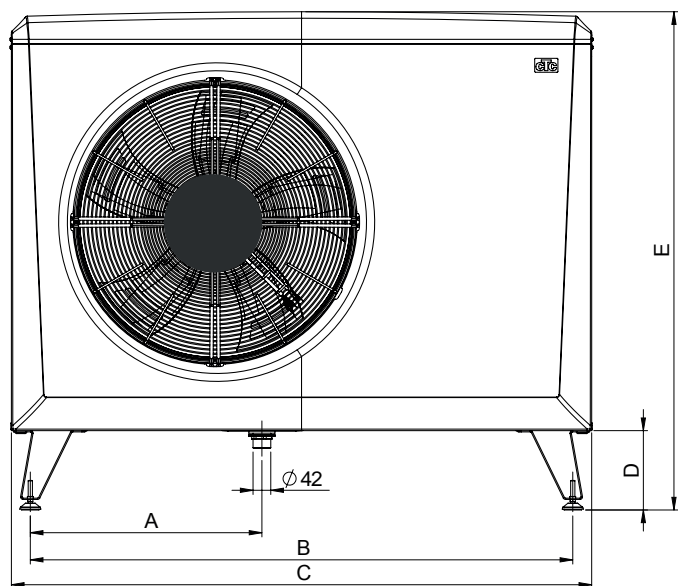

	CTC EcoAir 610M / 614M	CTC EcoAir 622M
A	486	550
B	1155	1285
C	1245	1375
D	188	188
E	1080	1180
F	308	308
G	476	476
H	451	551
I	Ø28	Ø28
J	85	83
K	545	645
L	10	33

## 3.2 Component location

Component location  
CTC EcoAir 610M / 614M / 622M

Configuration coils:

- ① AC coil: EcoAir 610M / 614M
- ②⑨ DC coil: EcoAir 622M

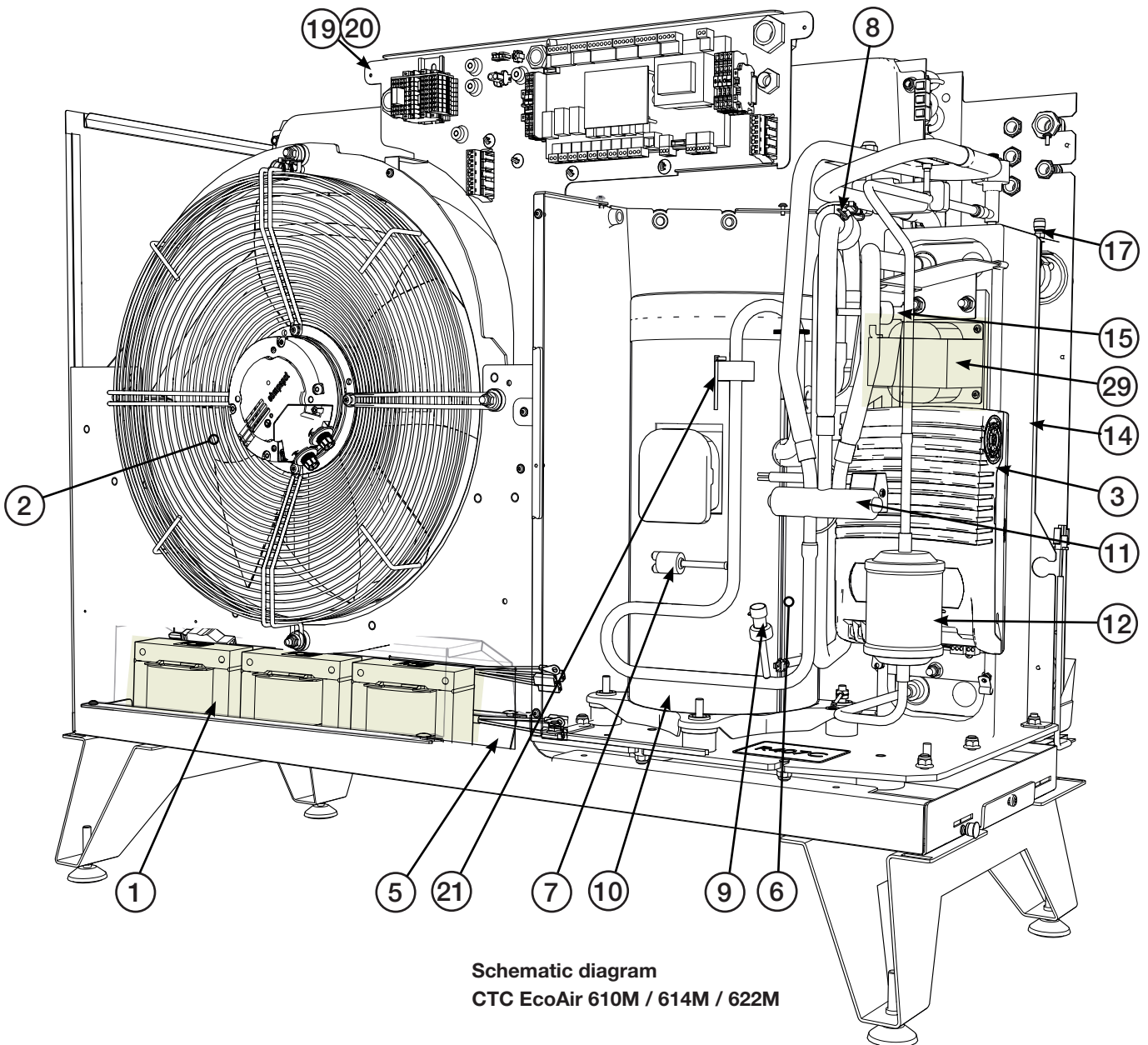
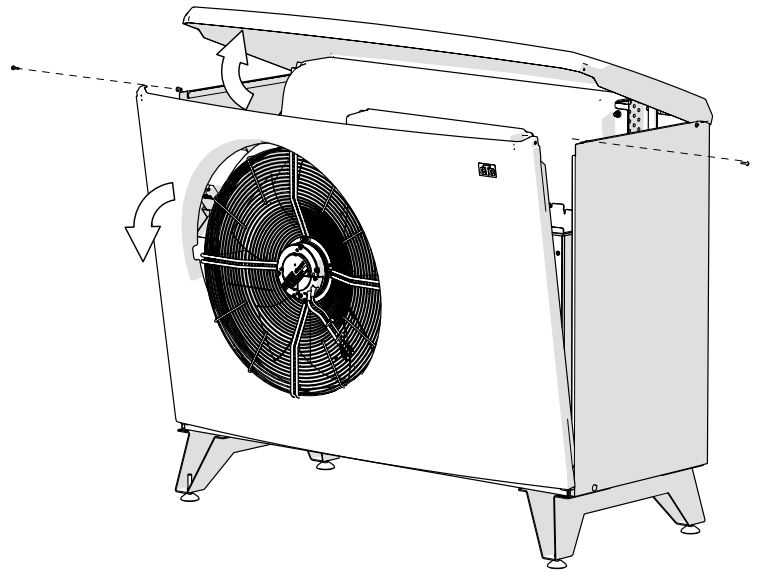

Schematic diagram  
CTC EcoAir 610M / 614M / 622M

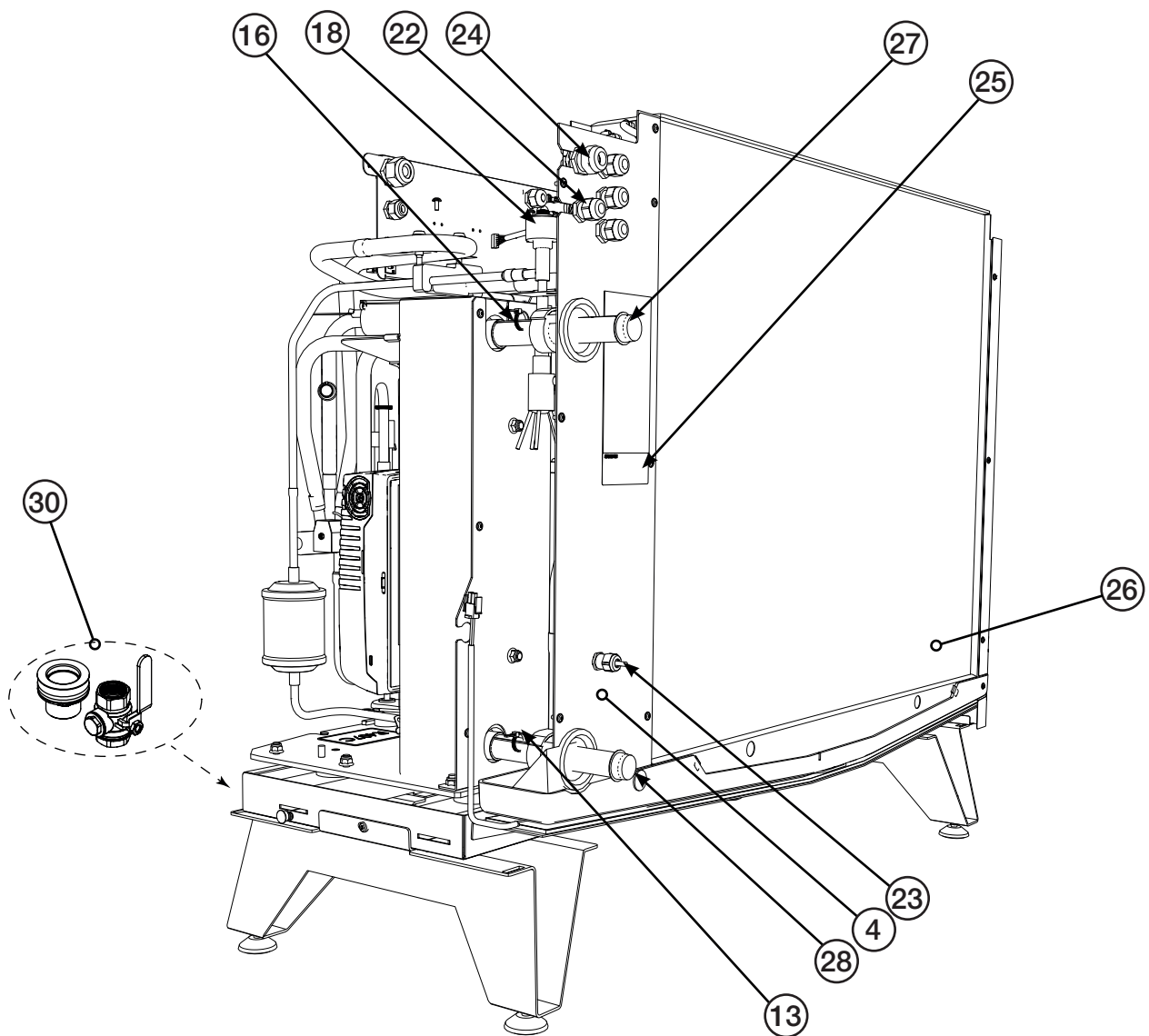

- |                                       |   |
|---------------------------------------|---|
| 1. AC coil                            | 16. Primary flow sensor   |
| 2. Fan                                | 17. Bleeding nipple/water   |
| 3. Frequency converter                | 18. Expansion valve   |
| 4. Defrosting sensor in evaporator    | 19. Connection box  |
| 5. Type plate with serial number etc. | 20. Communication   |
| 6. Compressor                         | 21. Discharge sensor  |
| 7. High pressure switch               | 22. Communication product   |
| 8. Suction gas sensor                 | 23. Outdoor sensor  |
| 9. High pressure sensor               | 24. Feeding product   |
| 10. Compressor heater                 | 25. Serial number   |
| 11. 4-way valve                       | 26. Evaporator  |
| 12. Drying filter                     | 27. Primary flow Ø28 mm   |
| 13. Return sensor                     | 28. Return flow Ø28 mm  |
| 14. Condenser                         | 29. DC coil   |
| 15. Low pressure sensor               | 30. Packaged components (filter ball valve and condensate drain) in box under product on pallet |

### 3.3 Refrigerant system

#### Refrigerant system CTC EcoAir 600M

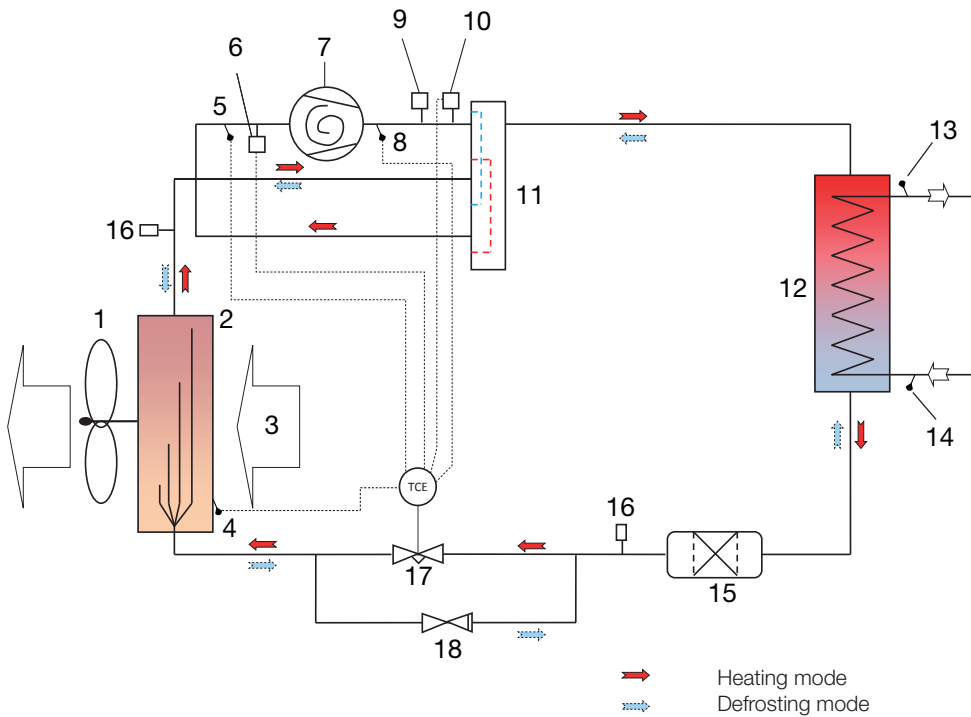

1. Fan
2. Evaporator
3. Air
4. Defrosting sensor (B16)
5. Suction gas sensor (B22)
6. Low pressure sensor (B101)
7. Compressor
8. Hot gas sensor (B21)
9. High pressure switch
10. High pressure sensor (B100)
11. 4-way valve
12. Condenser
13. Primary flow sensor (B1).
14. Return sensor (B7)
15. Drying filter
16. Schrader
17. Expansion valve
18. Non-return valve (only on CTC EcoAir 622M)

### 3.4 Operating range

The control system for the CTC EcoAir 600M monitors and ensures that the product is working within its operating range.

Primary flow C°

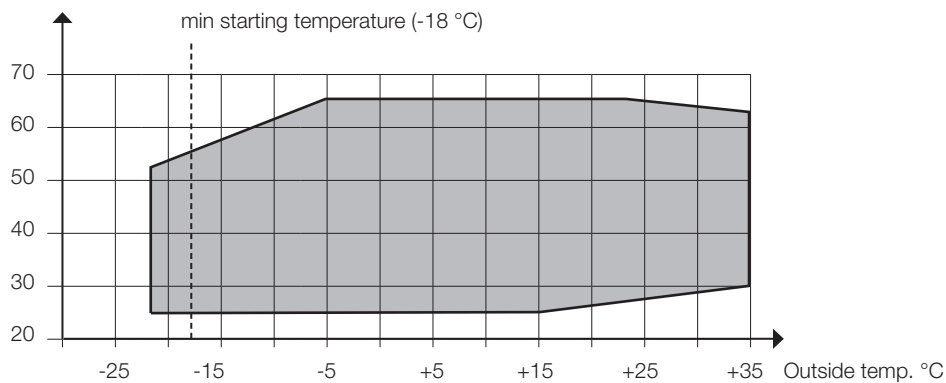

## 4. Installation

This section is aimed at anyone responsible for one or more of the installations required to ensure that the product works the way the property owner wants.

Take your time going through functions and settings with the property owner and answer any questions. Both you and the heat pump benefit from a user who has completely understood how the system operates and should be maintained.

The installation must be carried out in accordance with the applicable standards.

### 4.1 Delivery includes:

- 1 x Heat pump CTC EcoAir 600M.
- Packaged components (see chapter 'Component location').
  - Filter ball valve: G1" (EcoAir 610M / 614M), G1¼" (EcoAir 622M)
  - condensate drain: G1¼"
- 15 m cable LiYCY (TP 2x2x0.75 mm<sup>2</sup>) with connector for communication, fitted.
- 2 m power cable, fitted.

CTC EcoAir 610M / 614M	CTC EcoAir 622M
5G x 2.5 mm <sup>2</sup>	5G x 4 mm <sup>2</sup>

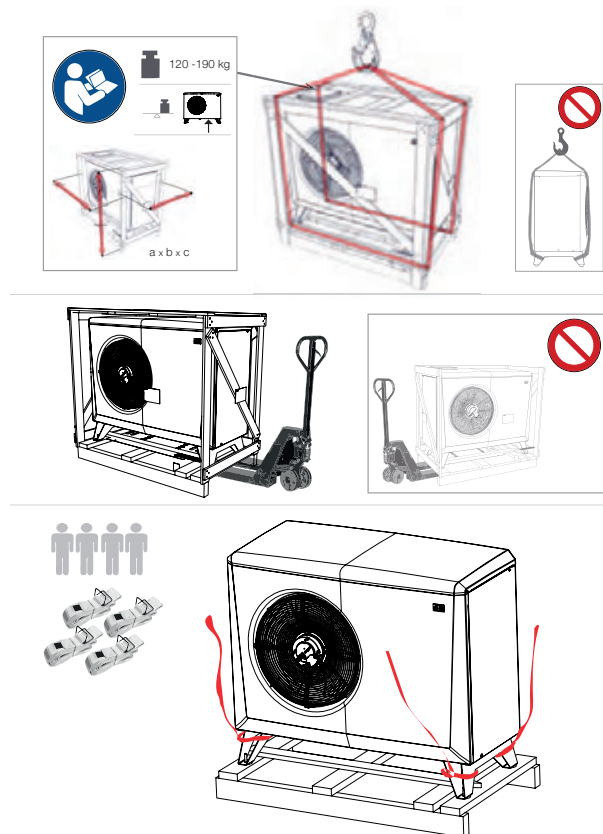

## 4.2 Location of the heat pump

- CTC EcoAir 600M is normally placed against an outside wall.
- The heat pump has a factory-fitted condensation water tray from which condensation water is conducted to a caisson, surface water drain, downpipe or other drainage equipment. You should therefore consider the position of the product.
- If the condensation water pipe is not used, the foundation must be such that condensing water and melted snow can drain into the ground. Make a 'stone curb' under the heat pump. Remove 70–100 cm and fill up with crushed stones to obtain the best possible drainage.
- The distance between wall and product is recommended to be at least 250 mm (EcoAir 610M / 614M) and 400 mm (EcoAir 622M) respectively, so that the outdoor air can flow through the evaporator without hindrance.
- Allow a space of at least 2 metres between the heat pump and any bushes etc.
- Place the heat pump so that noise from the compressor and fan does not disturb the surroundings.
- Do not place the heat pump right next to a bedroom window, patio or fence. Consider the distance to the nearest neighbour.
- The stand must stand stably on concrete blocks or similar.
- Use a spirit level to adjust the unit, so that it is completely level.
- Due to the design of the stand and the weight of the pump, it is not necessary to mount the unit to the ground or the wall.
- Installing the heat pump in a sheltered spot is inadvisable, and so is placing it in an outhouse or car port. because the air should flow as freely as possible through the heat pump and used air should not to be sucked into the inlet on the back. This can cause abnormal ice formation in the evaporator.
- If the product is located where it will be subjected to particularly harsh weather conditions, the product can be installed underneath a small awning.

**!** These guidelines must be followed in order for your CTC EcoAir 600M to give the optimal performance.

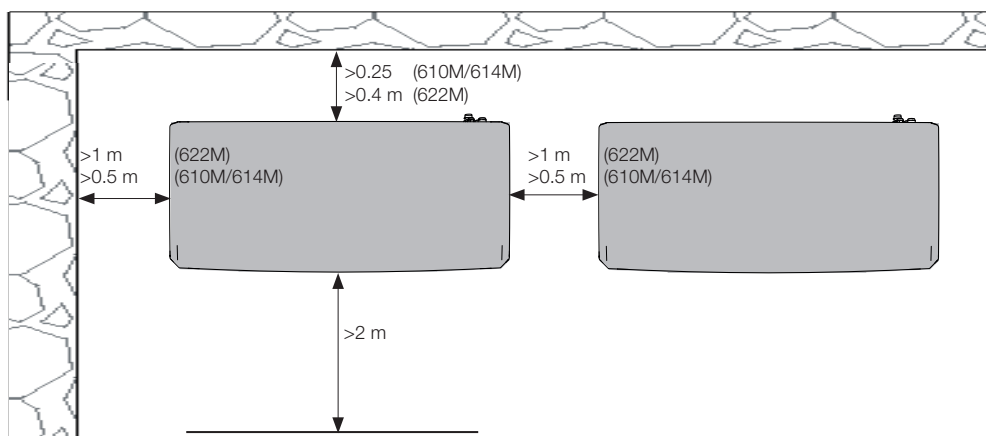

## 4.3 Preparation and drainage

The heat pump should be positioned so that the house cannot be damaged and the condensation water can easily drain into the ground. The base must be of concrete blocks or similar, resting on crushed stones or gravel.

- Make a 'stone curb' under the heat pump. Remember that there may be up to 70 litres of condensation water a day under some conditions.
- Dig a hole in the ground 70-100 cm deep.
- Place a moisture barrier in the hole on the side against the foundations of the building
- Half fill the hole with crushed stones and lay concrete blocks or similar.
- Mark the \*centre-to-centre (c.t.c) distances between the blocks for the heat pump stand.

"c/c-measurement	CTC EcoAir 610M / 614M	CTC EcoAir 622M
length (depth) mm	1155 (452)	1285 (552)

- Use a spirit level to ensure that the blocks are level.
- Place crushed stones around the blocks in order to achieve optimal drainage.

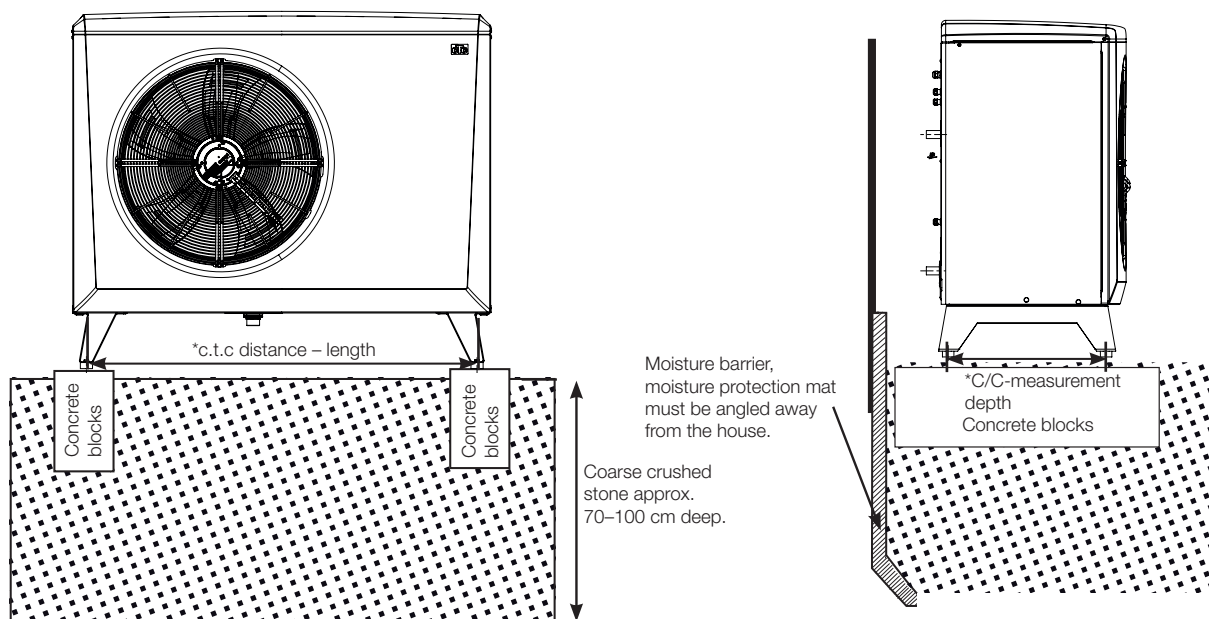

## 4.4 Condensation water

- The condensation tray is built into the heat pump and is used to divert most of the condensation water.  
The tray can be connected to an appropriate drain via the supplied condensate drain (G1¼"). Assemble the condensate drain by screwing together its top and bottom sections through the intended hole in the tray. The condensation trays in the EcoAir 610M and 614M models have a slot to facilitate mounting. Insert the condensate drain's top section between the condensation tray and evaporator (use the slot). Then turn the section so it is facing upwards and screw it to the bottom section of the condensation tray.

**The condensate drain must not be fitted if the drain is not used.**

- A heating cable (available as an accessory) should be placed in the pipe to prevent refreezing. The heating cable is connected to the electrical cabinet of the heat pump (must be carried out by a qualified electrician and in accordance with applicable regulations).
- If the house has a cellar, it is advisable to route the condensation water to a floor drain indoors (to be performed according to the applicable rules). The pipe should be installed with a slope towards the house and above the ground (so no other water can get into the cellar). Wall apertures should be sealed and insulated. A water trap must be connected to the inside to prevent air from circulating in the pipe.
- If there is a stone curb, the outlet from the condensation water pipe should be placed at a frost-free depth.
- The condensation water can also be conducted to the building's drainage, e.g. downpipe drains. Here a heating cable must be placed in pipes that are not frost protected.

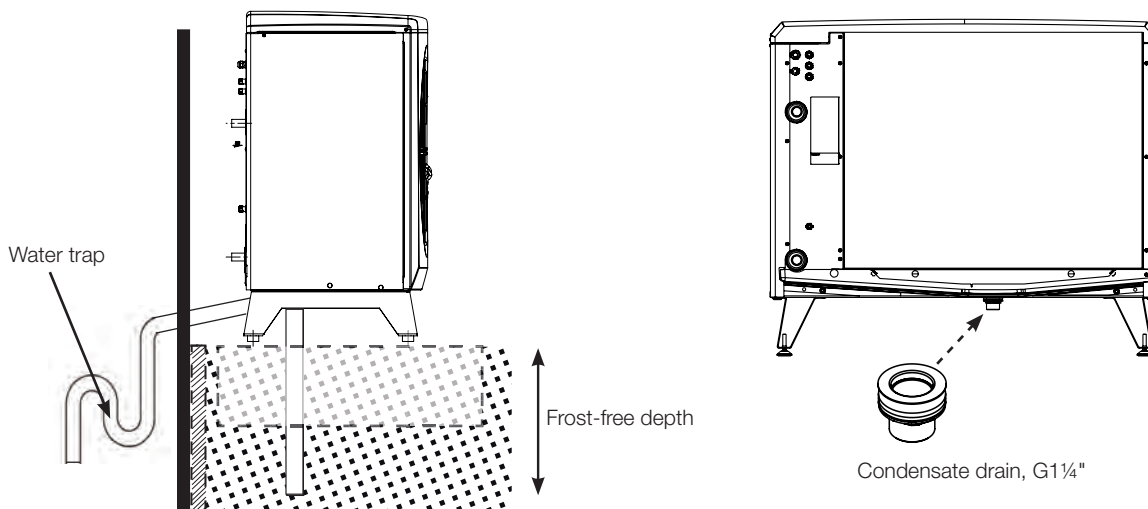

## 5. Pipe installation

The installation must be carried out in accordance with the applicable standards. The boiler must be connected to an expansion vessel in an open or closed system. Do not forget to flush the heating circuit clean before connection.

### 5.1 Pipe connection

- We recommend that the heat pump is connected with a pipeline of at least Ø28 mm copper pipe, but pressure differential calculations must be carried out to determine the pipe diameter.
- Route the pipes between the heat pump and the boiler without any highest points. If this cannot be done, provide this highest point with an automatic air separator or an in line aerator.
- Fit the packaged filter ball valve to the return line from the boiler. To clean the filter ball valve, refer to the chapter titled "Operation and Maintenance".
- The connection to the heat pump should be made with a wire-reinforced diffusion-tight hose for DHW, min 1" diameter (available as an accessory). A minimum of 1000 mm flexible hose is required to prevent noise transmission into the property and allow for movement of the heat pump.
- Pipes installed outside should be insulated with at least 13 mm thick pipe insulation which is not sensitive to water. Ensure that the insulation is sealed tightly everywhere and that joints are thoroughly taped or glued.
- Indoor pipes should be insulated all the way to the boiler with at least 9 mm thick insulation. This is to enable the heat pump to deliver the highest possible temperature to the boiler or tank without any losses.
- The product can be bled via the bleed valve inside the condenser. **Note Only bleed this valve. Other valves are for the cooling system! If these are opened, refrigerant may leak out!**

! If necessary, the radiator systems should be flushed clean before connecting.

! Minimum water volume in the heating circuit (>25 °C) for reliable defrosting functionality:

EcoAir 610M	80 l
EcoAir 614M	80 l
EcoAir 622M	120 l

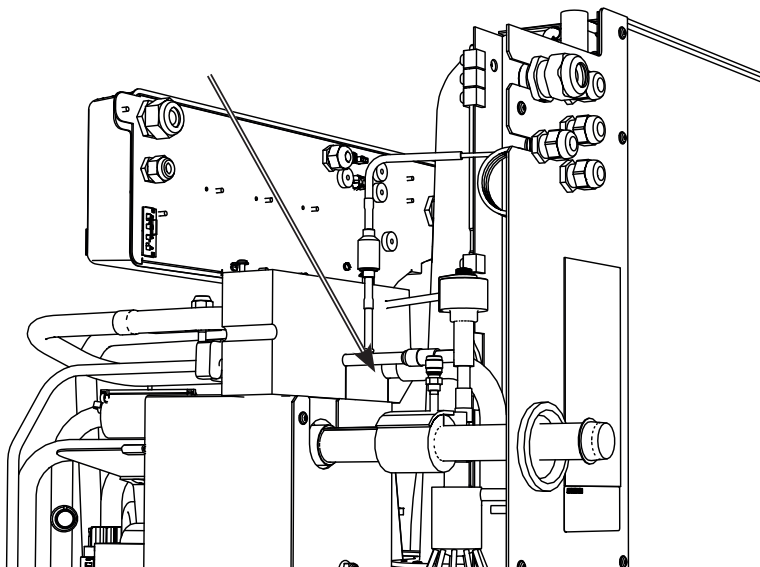

## 5.2 Example of connection to CTC EcoZenith i255 L

The CTC EcoZenith i255 L has pipes at the rear right edge for connection of the heat pump. The heat pump's lower connection is connected to the right connection when viewed from the front, so that water is pumped out to the heat pump. The heat pump's upper connection is thus connected to the left connection.

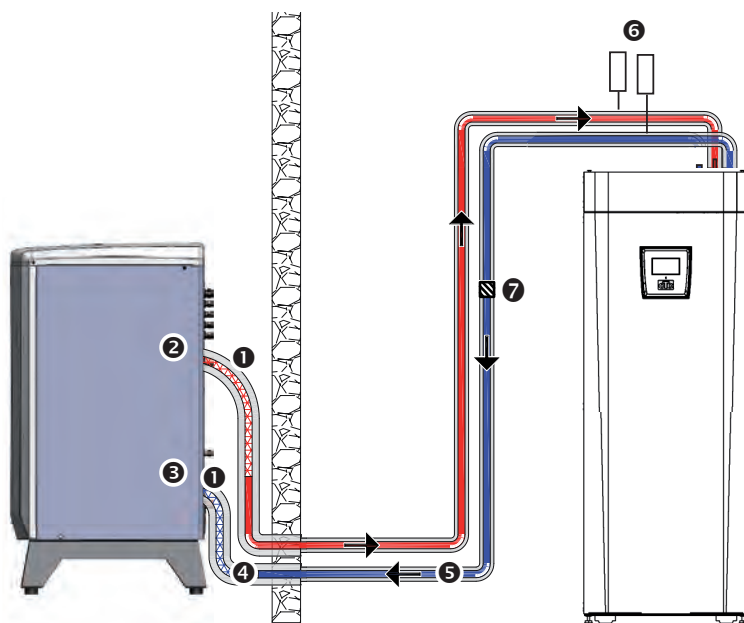

1. Flexible, wire-reinforced, impermeable hose for hot water, min. 1" (CTC accessory). Hose length 1,000 mm from the product.
2. Primary flow, outgoing (heated) water Ø28 mm connection on the condenser.
3. Return line, incoming (cold) water Ø28 mm connection on the condenser.
4. Ø28 mm copper pipe. insulated outdoors with 13 mm thick insulation.
5. Inside piping is insulated with 9 mm thick insulation.
6. Bleeder
7. Filter Ball Valve

### EcoAir/EcoZenith i255 H

On the CTC EcoZenith i255 H, the heat pump is connected directly to the charge pump located under the tank. The heat pump's lower connection must be connected to the charge pump so that water is pumped out to the heat pump. The heat pump's upper connection is connected to the right 3-way valve by the charge pump.

## 5.3 Circulating pump – heat carrier

The pump transports the heat from EcoAir to CTC EcoZenith. If the outdoor temperature is below +2°C the pump runs constantly to eliminate any risk of freezing.

If the product installed at a facility where power outages can occur, then it is advisable to supplement with an emergency power generator for the charge pump. It is also possible to install mechanical frost protection.

The product used for control monitors and ensures that the heat pump works within its operating range.

### Speed setting

The speed for the circulation pump is set in the "Installer/Settings/Heat pump" menu.

## Setting the temperature differential

For external control, a circulation pump is installed so that the right flow through the heat pump can be guaranteed.

Set the right temperature differential by adjusting the speed of the circulation pump. This is to ensure that the right differential for the current outdoor temperature is produced according to the table.

Outdoor temp. (°C)		-10	-5	0	+5	+7	+10
CTC EcoAir 610M / 614M	Primary flow 35 °C Flow = 0.21 l/s	4 °C	4.5 °C	5.5 °C	6.5 °C	7 °C	8 °C
CTC EcoAir 622M	Primary flow 35 °C Flow = 0.39 l/s	4 °C	5 °C	6 °C	6.5 °C	7 °C	8 °C

In some systems the entire radiator flow goes through the heat pump, which means the pump must be sized according to the flow of the entire system.

For safe operation, the following flows should be considered:

- 760 l/h (CTC EcoAir 610M / 614M)
- 1400 l/h (CTC EcoAir 622M)

This provides a temperature differential of approx. 7 °C for an outside temperature of +7 °C and a primary flow temperature of 35 °C.

## 5.4 Pressure differential diagram for CTC EcoAir 600M

Pressure differential (kPa)

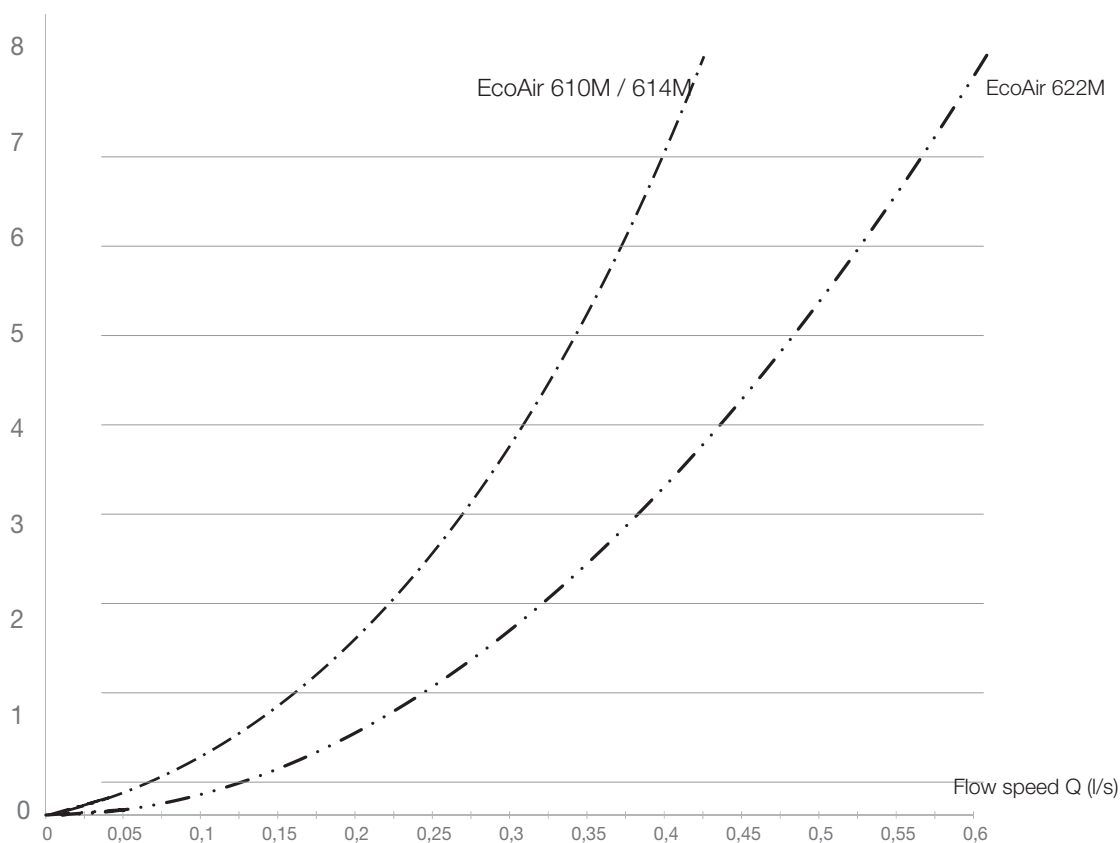

## 6. Electrical installation

### 6.1 General information, electrical connections



Installation and heat pump connection must be performed by an authorised electrician. All wiring must be installed according to applicable provisions. Before the front panel is opened or other live components are made accessible, the power supply to the heat pump must be fully disconnected.

#### Omnipolar safety switch

The installation should be preceded by an all-pole safety switch according to overvoltage category III, which ensures disconnection from all electric power sources.

Even if a residual current device is used, CTC EcoAir must still be fitted with its own residual current device with on/off delay.

### 6.2 Electric installation 400V 3N~

CTC EcoPart 600M must be connected to 400V 3N~ 50 Hz with protective earth.

The 2 m long power supply cable is pre-connected to the product.

### 6.3 Compressor heater

The compressor heater automatically heats up when the compressor is cold.

The compressor heater is pre-connected on delivery.

### 6.4 Heat pump connections

Ensure that the heat pump dip switch 2 is in the "ON" position (Factory setting).

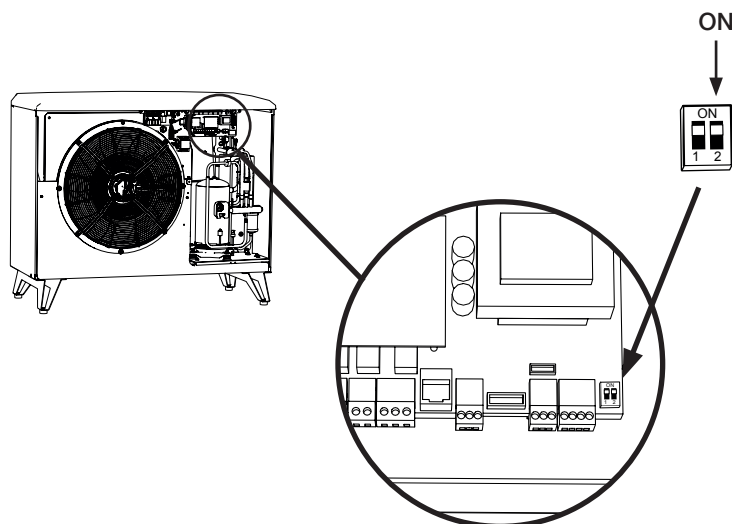

- CTC EcoAir 614M / 622M must not be supplied with power through the CTC EcoZenith i250/i255.
- The installation should be preceded by an omnipolar switch.
- Even if a residual current device is used, CTC EcoAir must still be fitted with its own residual current device with on/off delay.

## 6.5 Series connection of the CTC EcoAir 600M

### 6.5.1 Series connected heat pump connections

In a series connection, dip switch 2 must be set to the "OFF" position on all heat pumps except the last one, which should be set to "ON".

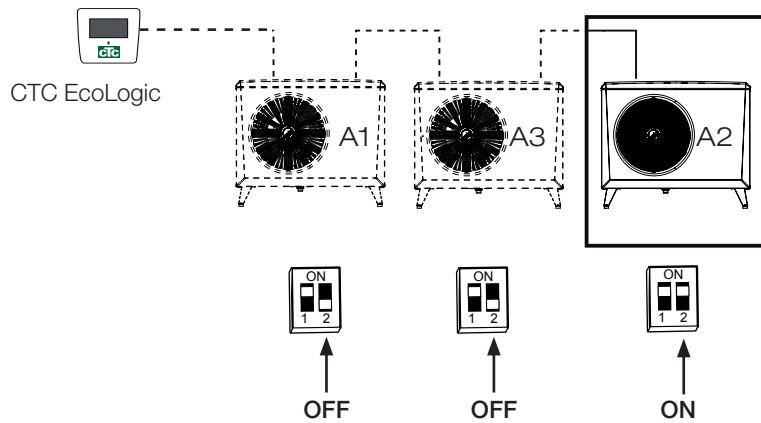

**!** The last heat pump connected in series must be set to the ON position.

## Heat pumps in series connection

## The last heat pump connected in series

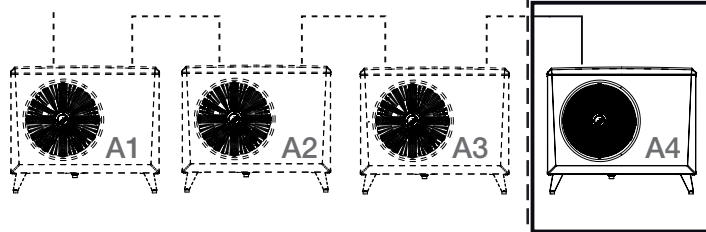

OFF



OFF



OFF



ON

**B A G Sc**  
Brown  
White  
Green  
Display

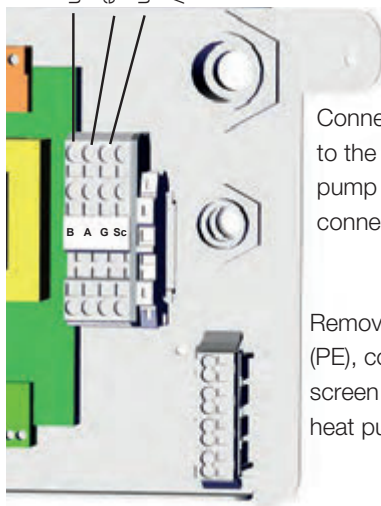

Connect each cable to the next heat pump in the series connection here.

Remove the jumper (PE), connect the screen to the next heat pump here.

**B A G Sc**  
Brown  
White  
Green  
Display

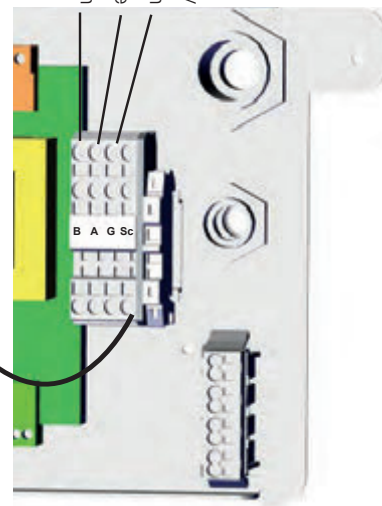

Make sure DIP switch 2 is in the ON position on the last heat pump in the series connection.

The jumper (PE) must be left in place.

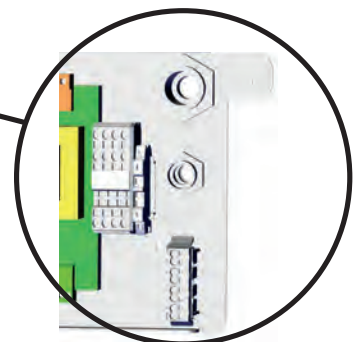
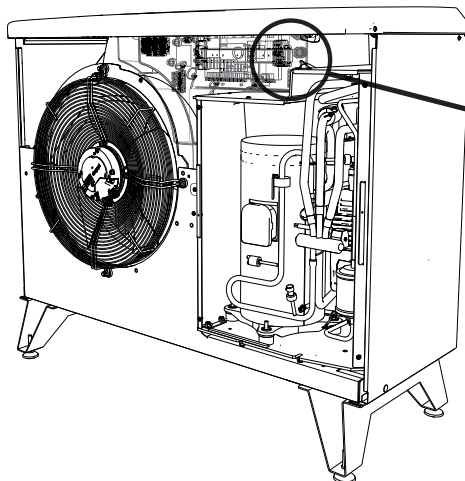

## 6.6 Communication connection

### 6.6.1 Connection options for one heat pump

When connecting CTC EcoAir 600M to CTC EcoZenith i255, CTC EcoZenith i360, CTC EcoZenith i555 Pro\*, CTC EcoVent i360F and CTC EcoLogic, the communication cable (LiYCY (TP)) must be connected directly to the respective products.

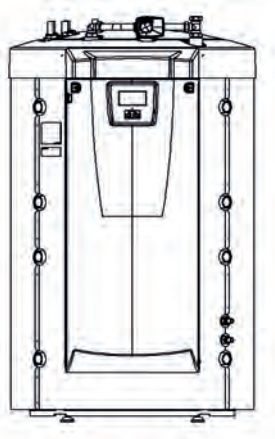

CTC EcoZenith i550/i555 Pro  
(CTC EcoAir 614M / 622M)



CTC EcoLogic

**!** \*CTC EcoZenith i555 Pro does not control CTC EcoAir 610M.

All heat pumps are supplied as VP1

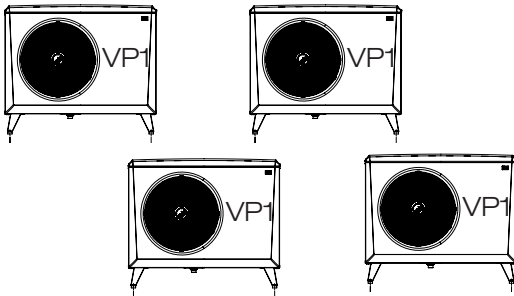

## 6.7 Alarm output

The CTC EcoPart 600M is fitted with a potential-free alarm output which is activated if any alarm is active in the heat pump. This output may be connected to a maximum load of 1 A 250 V AC. A cable approved for 230 V AC must be used for connecting this output, irrespective of the load that is connected. For connection information, see the wiring diagram.

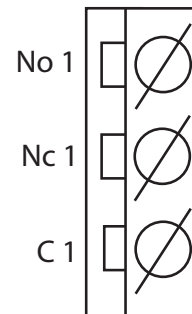

Close-up from wiring diagram.

## 6.8 Connecting the control system

### 6.8.1 Define number of heat pumps

Define the heat pumps in the controlling product's display under: "Advanced/Define system/Heat pump".

Set the heat pumps contained in the system to position "On".

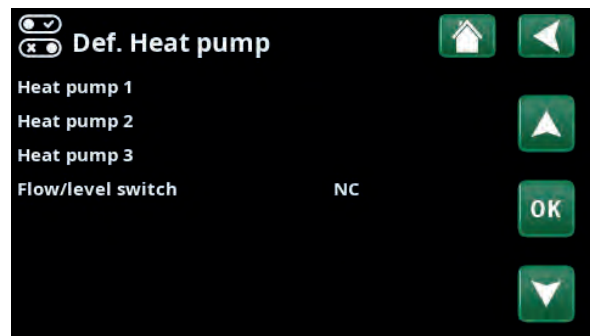

Example of a system with 3 heat pumps.

### 6.8.2 Numbering CTC EcoPart 600M to VP2

Applies to control launched in October 2020 with three connectors on the back of the display. 2 RJ-45 and 1 RJ-12.



1. System disconnected from power.

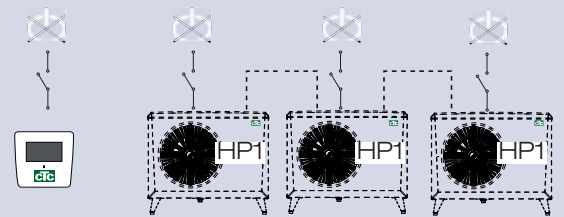

2. Energise the control (EcoLogic or EcoZenith i555 Pro) as well as the CTC EcoPart 600M which will be numbered as Heat Pump 2 (VP2).

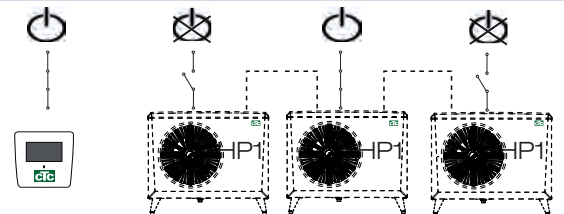

3. Wait for about 2 minutes.

4. Go to "Installer/Service/Set Address".

Select "Current address", press OK and press the down arrow until the current heat pump appears (VP1) Press OK.

Select "New address", press OK and use the arrow to scroll up and down until the address of the current heat pump address is shown (VP2). Press OK.

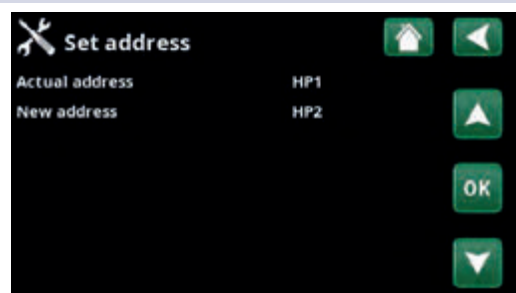

**!** \*CTC EcoZenith i550 Pro does not control CTC EcoAir 610M.

5. The heat pump is now numbered (VP2).

When you press OK, (VP1 and VP2)\* disappears and the row "Current address/New address" will go dark.

*\*In this example, we have assumed that the heat pump is called VP1, which is the factory default. If the heat pump has already been renumbered, then select this number instead.*

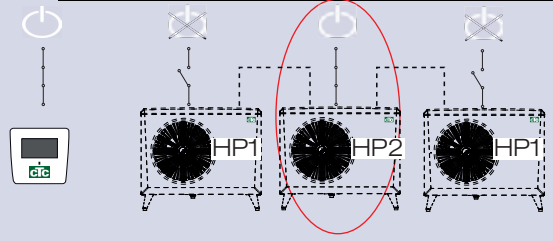
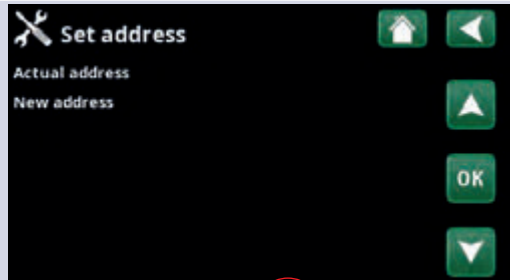

6. Number the other heat pumps:

Energise the next heat pump, which will be numbered heat pump 3 (VP3).

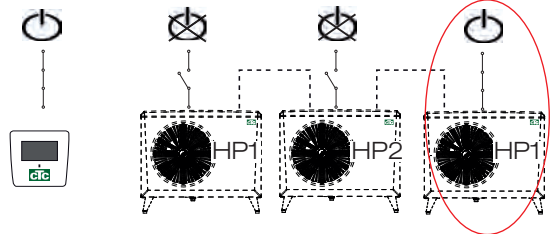

7. Wait 2 minutes.

8. Go to "Service/Set Address".

Select "Current address", press OK and press the down arrow until the current heat pump appears (VP1) Press OK.

Select "New address", press OK and press the up arrow until the current heat pump address appears (VP3). Press OK.

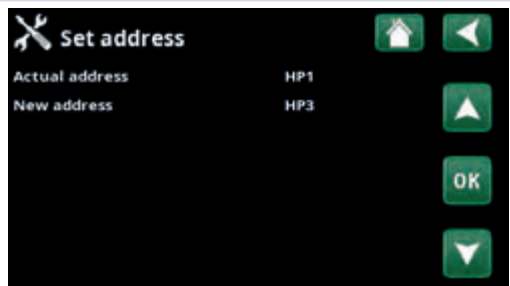

9. The heat pump is now numbered (VP3).

When you press OK, (VP1 and VP3)\* disappears and the row "Current address/New address" will go dark.

*\*In this example, we have assumed that the heat pump is called VP1, which is the factory default. If the heat pump has already been renumbered, then select this number instead.*

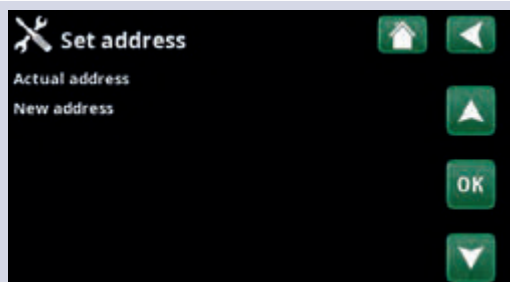

10. Redo the procedure according to the number of heat pumps to be numbered.

When all heat pumps are numbered and energised, they should be displayed when you press the heat pump symbol in the menu "Operation data". If any heat pump does not appear in the menu (communication with the heat pump fails) It may be because it has not been numbered as described above.

If you do not know the name of the heat pump, you can reset the numbering by using the "Select/Rename Heat Pump" menu (refer to points 9 and 10 above) to indicate all possible names of the heat pump, i.e. you select and confirm VP1 and then VP2 up to VP10 to ensure that the correct name is given.

Finally test in the menu "Installer/Service/Function test/Heat pump" that the respective heat pump starts.

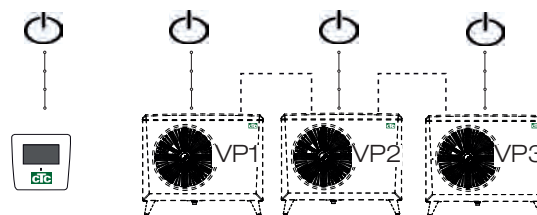

### 6.8.3 Worth knowing when addressing

#### Error set Address

The heat pump could not be found and numbered.

The heat pump was not what it was supposed to be called.

No communication with the heat pump.

Check that the heat pump is energised.

If the setting of the address fails, the latest heat pump addresses remain. In this example VP1 and VP2.

Make sure the heat pump is energised.

Try again with a new current address.

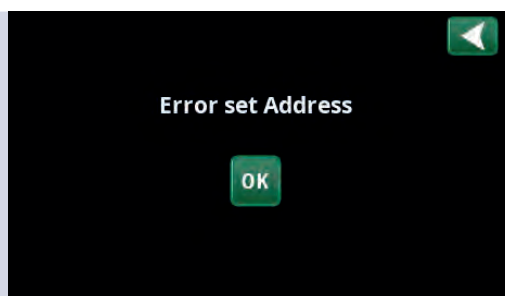

## 6.8.4 Numbering CTC EcoPart 600M as A2

Applies to older controls with 2 connectors on the back of the display.

1 RJ-45 and 1 RJ-12 for the CTC EcoZenith i550 Pro and CTC EcoLogic Pro/Family.

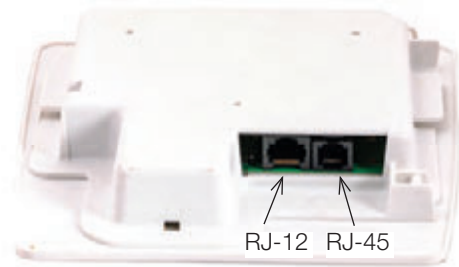

1. System disconnected from power.

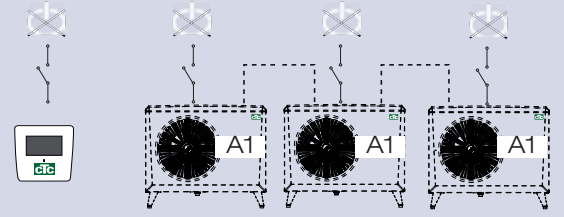

2. Energise the control (EcoLogic Pro or EcoZenith i550 Pro) as well as the CTC EcoPart 600M which will be numbered as Heat Pump 2 (VP2).

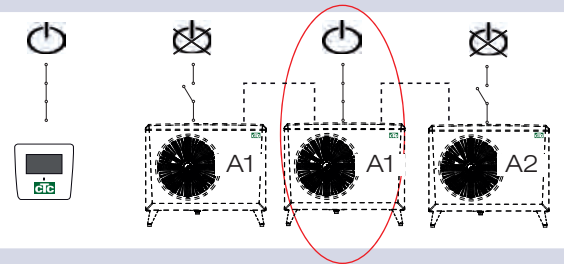

3. Wait approx 2 minutes until the heat pump is visible in the "Operation data" menu.



4. Go to Installer/Settings/Heat pump 2 and the row "Select/Rename Heat pump". Press OK.

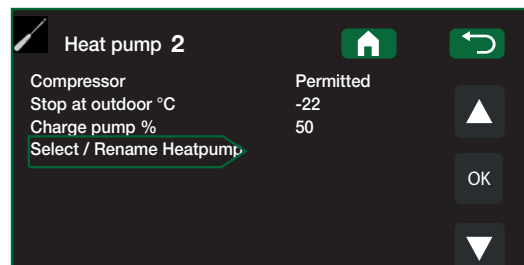

5. Press the arrow up until (A1)\* is displayed. Press OK.

After pressing OK, (A1)\* disappears and the "Select/Rename Heat Pump" row darkens.

*\*In this example, we have assumed that the heat pump is called A1, which is the factory default. If the heat pump has already been renumbered, then select this number instead.*

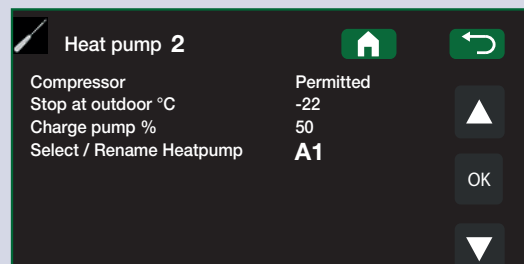

**!** \*CTC EcoZenith i550 Pro does not control CTC EcoAir 610M.

6. The heat pump is now numbered (A2).

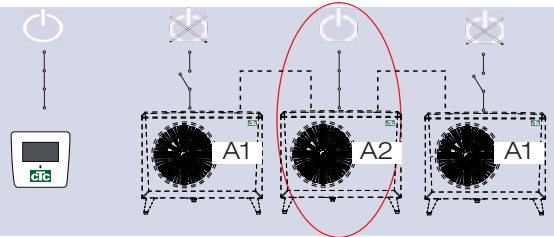

7. To number the other heat pumps:

Energise the control and the next heat pump to be numbered to heat pump 3 (A3).

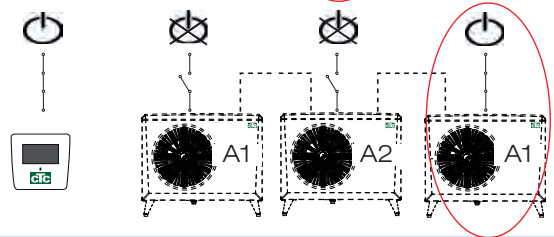

8. Wait approx 2 minutes until the heat pump is visible in the operational information.

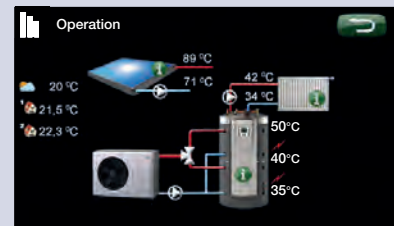

9. Go to Installer/Settings/Heat pump 3 and the row "Select/Rename Heat pump". Press OK.

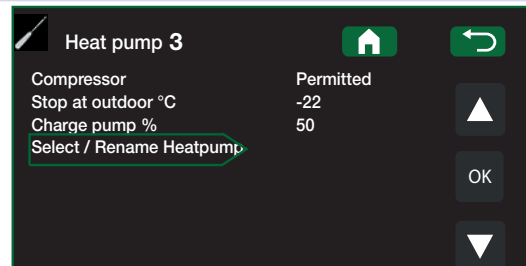

10. Press the arrow up until (A1)\* is displayed. Press OK.

After pressing OK, (A1)\* disappears and the "Select/Rename Heat Pump" row darkens. The heat pump is now numbered (A3).

*\*In this example, we have assumed that the heat pump is called A1, which is the factory default. If the heat pump has already been renumbered, then select this number instead.*

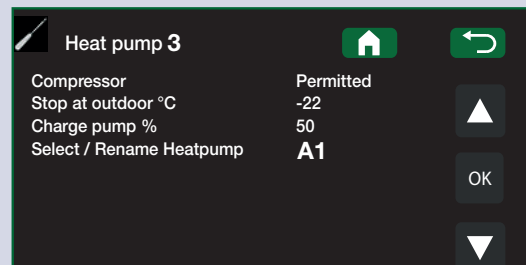

11. Redo the procedure according to the number of heat pumps to be numbered.

When all heat pumps are numbered and energised, they should be displayed when you press the heat pump symbol in the menu "Operation data". If any heat pump does not appear in the menu (communication with the heat pump fails) It may be because it has not been numbered as described above.

If you do not know the name of the heat pump, you can reset the numbering by using the "Select/Rename Heat Pump" menu (refer to points 9 and 10 above) to indicate all possible names of the heat pump, i.e. you select and confirm A1 and then A2 up to A10 to ensure that the correct name is given.

Finally test in the menu "Advanced/Service/Function test/Heat pump" that the respective heat pump starts.

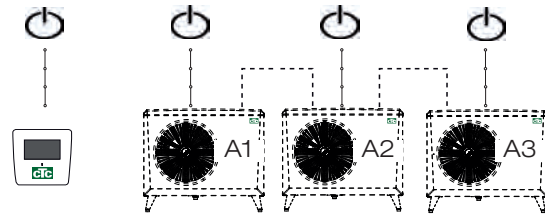

## 6.9 Wiring diagram 400V 3N~ (A3)

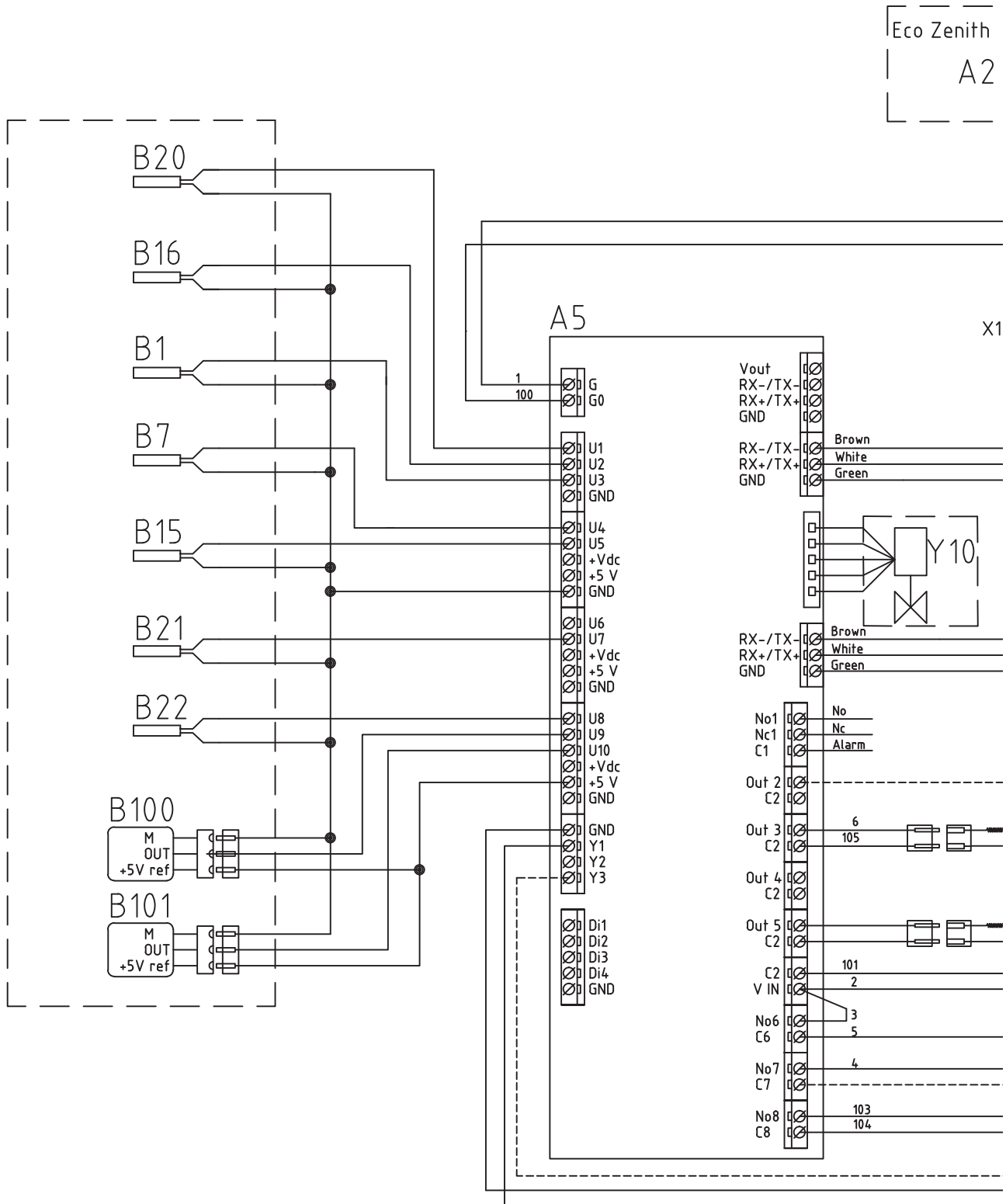

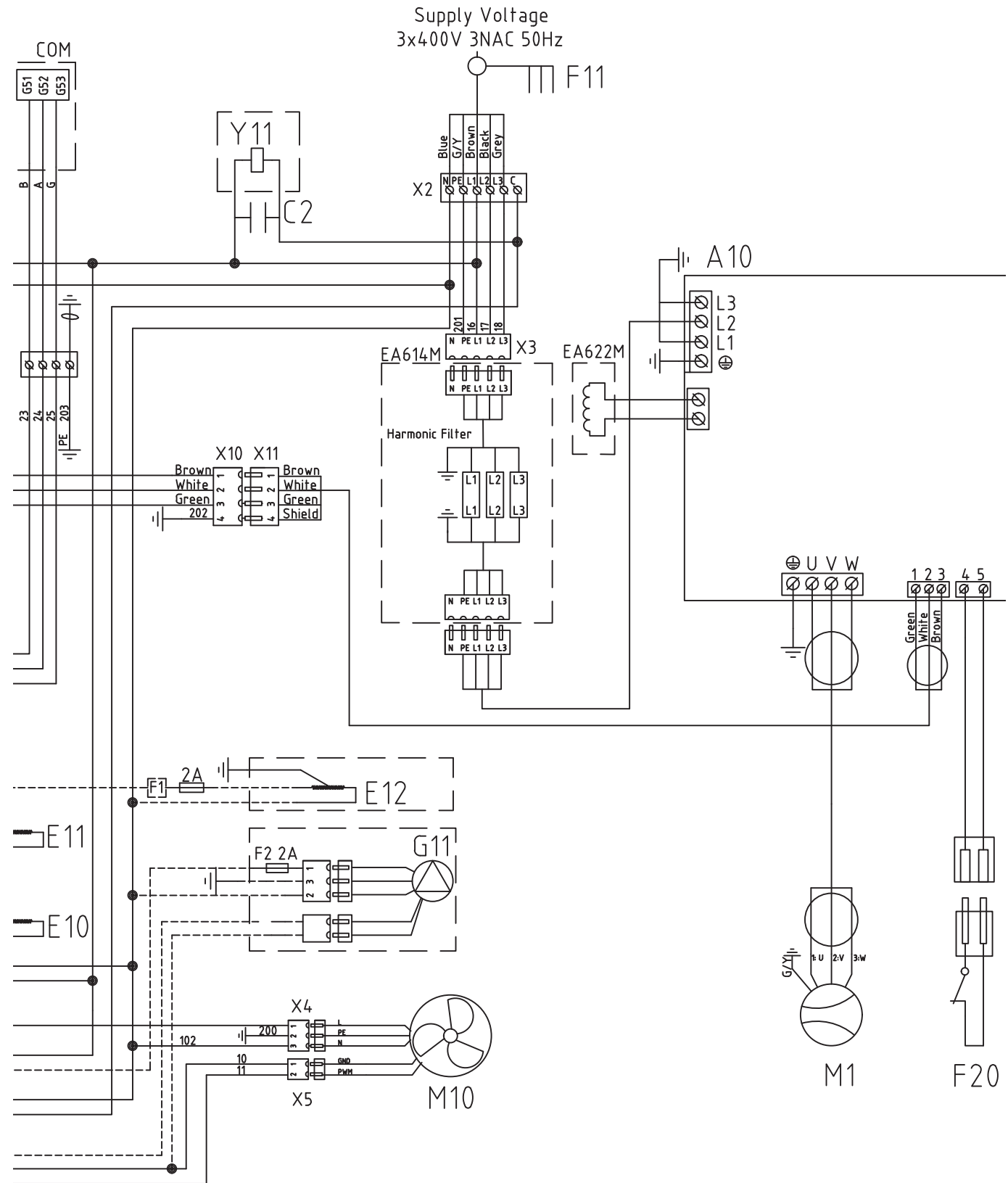

## 6.10 Wiring diagram 400V 3N~ (A4)

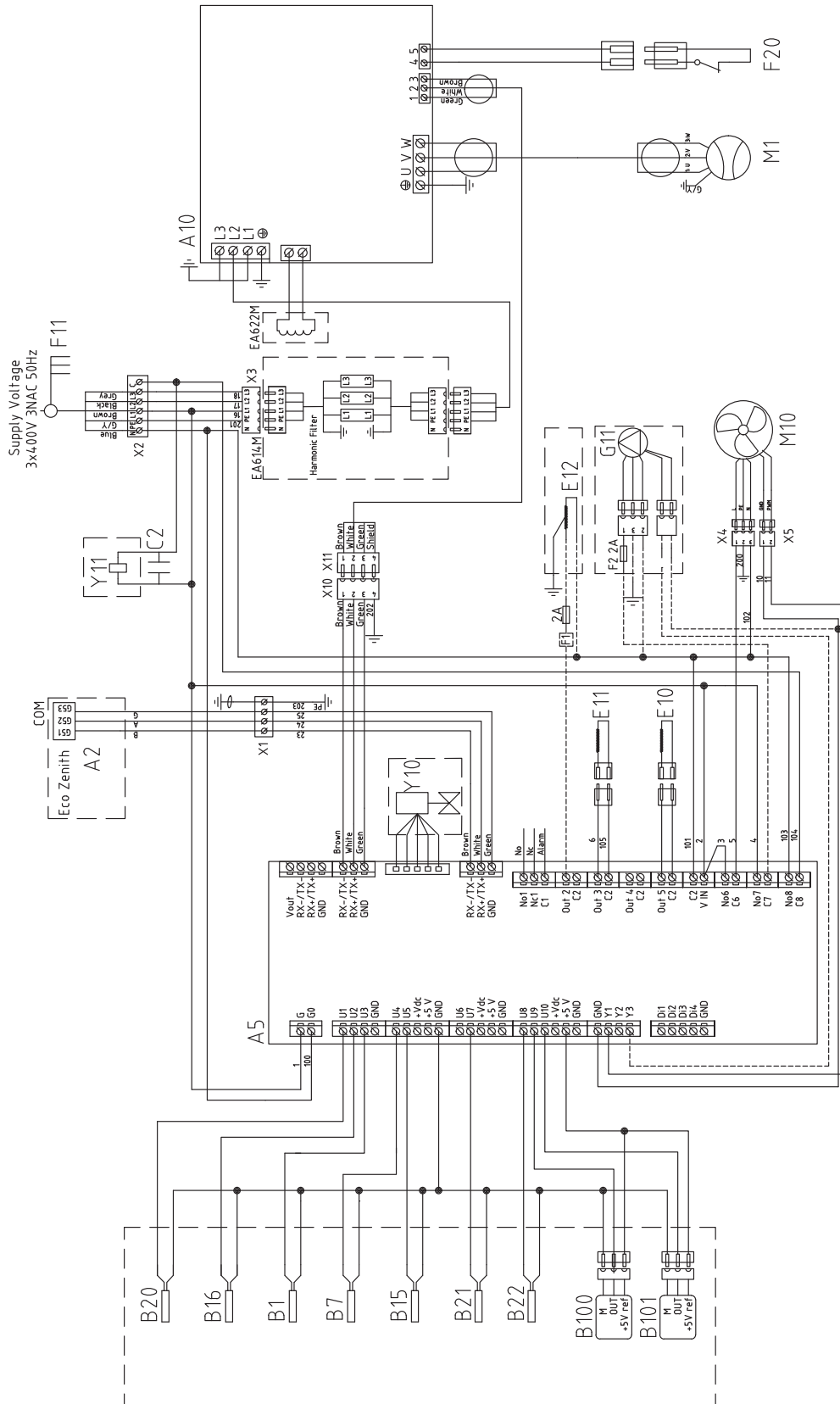

## 6.11 Parts list

A1	Display (CTC EcoZenith i255/i360)	
A2	Relay/main card (CTC EcoZenith i255/i360/CTC EcoVent i360F)	
A5	HP control card	
A10	Frequency converter	
B1	Primary flow sensor	Type 2 NTC
B7	Return sensor	Type 2 NTC
B15	Outdoor sensor	Type 1 NTC
B16	Defrosting sensor	Type 1 NTC
B21	Discharge sensor	Type 3 NTC
B22	Suction gas sensor	Type 1 NTC
B100	High pressure sensor	
B101	Low pressure sensor	
C1	Condenser compressor (1-phase)	
C2	Condenser	
E10	Compressor heater	
E11	Condenser tray heater	
E12	Heating cable (option)	
F1	Fuse (option)	
F11	Omnipolar switch	
F20	High pressure switch	
L1	Spool	
M1	Compressor	
M10	Fan	
X1	Terminal block	
XM1	Connector supply Male	
XM2	Connector supply Female	
XC1	Connector compressor Male	
XC2	Connector compressor Female	
Y10	Expansion valve	
Y11	Solenoid valve	
Z1	EMC filter	

## 6.12 Sensor Data

Temperature °C	Sensor Type 1 NTC Resistance kΩ	Temperature °C	Sensor Type 2 NTC Resistance kΩ	Temperature °C	Sensor Type 3 NTC Resistance kΩ
100	0.22	100	0.67	130	5.37
95	0.25	95	0.78	125	6.18
90	0.28	90	0.908	120	7.13
85	0.32	85	1.06	115	8.26
80	0.37	80	1.25	110	9.59
75	0.42	75	1.47	105	11.17
70	0.49	70	1.74	100	13.06
65	0.57	65	2.07	95	15.33
60	0.7	60	2.5	90	18.1
55	0.8	55	3.0	85	21.4
50	0.9	50	3.6	80	25.4
45	1.1	45	4.4	75	30.3
40	1.3	40	5.3	70	36.3
35	1.5	35	6.5	65	43.6
30	1.8	30	8.1	60	52.8
25	2.2	25	10	55	64.1
20	2.6	20	12.5	50	78.3
15	3.2	15	15.8	45	96.1
10	4	10	20	40	119
5	5	5	26	35	147
0	6	0	33	30	184
-5	7	-5	43	25	232
-10	9	-10	56	20	293
-15	12	-15	74	15	373
-20	15	-20	99	10	479
-25	19	-25	134	5	619
-30	25	-30	183		

## 7. First start

1. Check that the boiler and system are full of water and have been bled.
2. Check that all connections are tight.
3. Check that sensors and the charge pump are connected to the power source.
4. Energise the heat pump by switching on the operating switch (the main switch).

Once the system has heated up, check that all connections are tight, the various systems have been bled, heat is coming out into the system and warm water is coming out at the tap locations.

## 8. Operation and Maintenance

When the installer has installed your new products, you should check along with the installer that the system is in perfect operating condition. Let the installer show you where the power switches, controls and fuses are so that you know how the system works and how it should be maintained. Bleed the radiators (depending on type of system) after around three days of operation and top up with water if required.

### Defrost

The CTC EcoAir 600M is fitted with hot gas defrosting. The heat pump checks constantly whether defrosting is needed and, if so, defrosting starts, the fan stops, the 4-way valve changes direction and the discharge goes to the evaporator instead. A hissing sound is heard as the water drains from the evaporator. There may be large amounts of water. When the product has defrosted, the fan starts and the discharge goes into the condenser instead, and the heat pump returns to normal operation.

### Modulating compressor

The power in the heat pump is adapted using modulating operation according to the actual energy requirement. The compressor runs constantly with the correct power and thereby minimises the number of start and stop periods. The modulating power regulation provides optimal efficiency.

### The fan

The fan starts 15 seconds before the condenser and runs until the compressor stops. During defrosting the fan stops and restarts when defrosting is finished. The fan is speed-controlled and follows the need for power.

### Maintenance

A large amount of air passes through the evaporator. Leaves and other debris can get stuck and restrict the air flow. At least once year the evaporator coil should be checked and cleared of particles that block the air flow. The evaporator and outer covering should be cleaned with a damp cloth or soft brush. No other periodic maintenance or inspection is necessary.

## Periodic maintenance

After three weeks of operation and every three months of the first year, thereafter once a year:

- Check that the installation is free of leaks.
- Check that the product and system are free of air; bleed if needed.
- Check that the evaporator is clean.
- The products do not require annual inspection for refrigerant leakage.
- Clean the filter ball valve located on the heat pump's return flow. Refer to the chapter titled "Cleaning the Filter Ball Valve".

## Cleaning the Filter Ball Valve

1. Turn off the heat pump with the omnipolar switch.
2. Close the valve (switch to the OFF position) and unscrew the cover underneath.
3. Use lock ring pliers to remove the lock ring securing the filter.
4. Remove the filter and rinse clean.
5. Refit the filter and lock ring.
6. Reattach the cover carefully and make sure to not pinch the O-ring gasket.

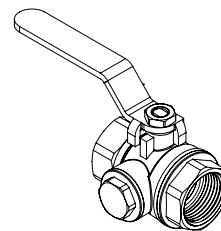

Switch the filter ball valve to the "ON" position.

## Operation stop

The heat pump is shut down using the operating switch. If there is a risk of the water freezing, ensure that there is circulation, or drain out all the water from the heat pump.

## Condensation water tray

The condensation water tray collects water formed on the EcoAir's evaporator during operation and defrosting. The condensation water tray is equipped with an electric heating coil which keeps the tray free of ice when it is freezing outside. The condensation water tray is located at the bottom on the back of EcoAir. By lifting the handle on the cover plate and pulling it out, you can clean and inspect the condensation tray.

As an accessory you can buy a heating cable to connect to EcoAir. The cable is fitted in the drain from the condensation tray to the frost-free drain.



Condensate tray and drain.

## 9. Troubleshooting/Appropriate measures

The CTC EcoAir 600M is designed to provide reliable operation and high levels of comfort, and to have a long service life. Various tips are given below which may be helpful and guide you in the event of an operational malfunction.

If a fault occurs, you should always contact the installer who installed your unit. If the installer believes the malfunction is due to a materials or design fault, then they will contact us to check and rectify the issue. Always provide the product's serial number.

### Air problems

If you hear a rasping sound from the heat pump, check that it is properly bled. Top up with water where required, so that the correct pressure is achieved. If this noise recurs, call a technician to check the cause.

### Alarm

Any alarms and information texts from the CTC EcoAir 600M are displayed in the product which is used to control it; you should therefore consult the manual for that product.

### Circulation and defrosting

If the circulation between the indoor and the outdoor unit is reduced or stops, the high pressure switch is triggered.

Possible reasons for this:

- defective circulation pump/circulation pump too small.
- air in the pipes.
- condenser clogged.
- other intermediate obstructions to the water flow.

During defrosting the fan stops but the compressor operates and the melted snow and ice flows into the condensation tray under the heat pump. When defrosting stops, the fan starts again and initially a vapour cloud, consisting of damp air which condenses in the cold outdoor air, is created. This is perfectly normal and stops after a few seconds. If the pump heats poorly, check that no unusual ice formation has occurred.

Possible reasons for this:

- defective defrosting automation.
- Lack of refrigerant (leakage).
- Extreme weather conditions.









