



Providing sustainable energy solutions worldwide

Installation and Maintenance Manual

CTC EcoAir

Model 406 | 408 | 410 | 415 | 420

Air source heat pump

400V 3N~/ 230V 1N~

IMPORTANT

READ CAREFULLY BEFORE USE
KEEP FOR FUTURE REFERENCE



Installation and Maintenance Manual

162 205 51-2 2018-08-31

CTC EcoAir

Model 406 | 408 | 410 | 415 | 420

Air source heat pump



Table of Contents

Checklist	7	10. Connecting the control system	27
1. Technical data	8	10.1 General	27
1.1 Table 400V 3N~	8	10.2 Connection alternative 1, one heatpump	27
1.2 Table 230 V 1N~	9	10.3 Connection alternative 2, heatpumps in series.	27
1.3 Dimensional drawing	10	10.4 Connection alternative 3	28
1.4 Refrigerant system	11	10.5 Connection alternative 4	29
1.5 Component location	12	10.6 Connection alternative 5	30
2. Connection alternative CTC EcoAir 400	14	10.7 Parts list	31
2.1 General	14	10.8 Wiring diagram 400 V 3N~	32
3. Important to remember!	15	10.9 Wiring diagram 230V 1N~	34
3.2 Transportation	15	11. First start	36
3.3 Positioning	15	12. Noise data	36
3.4 Recycling	15	12.1 Sensor data	37
3.5 After commissioning	15	13. Operation and Maintenance	39
4. Installation	16	13.1 Defrosting	39
5. Placement of the heat pump	17	13.2 The fan	39
6. Preparation and drainage	18	13.3 Maintenance	39
6.1 Condensation water	19	13.4 Periodic maintenance	39
7. Pipe installation	20	13.5 Shut-down	39
7.1 Pipe connection	20	13.6 Condensation water tray	39
7.2 Example pipe connection	21	14. Troubleshooting/measures	40
8. Circulation pump	22	14.1 Air problems	40
8.1 Control/supply	23	14.2 Alarms	40
8.2 Operating range	23	14.3 Circulation and Defrosting	40
9. Electrical installation	24		
9.1 Electrical installation 400V 3N~	24		
9.2 Electrical installation 230V 1N~	24		
9.3 Safety switch	24		
9.4 Alarm output	24		
9.4.1 Termination one heat pump	24		
9.4.2 Termination for connection of heat pumps in series	25		
9.4.3 Heatpump in series - address	25		
9.4.4 Connection CTC Basic Display	25		

Safety instructions



Turn off the power with an omnipolar switch before doing any work on the product.



The product must be connected to protective earth.



The product is classified as IP X4.



When handling the product with a hoist ring or similar device, make sure that the lifting equipment, eyebolts and other parts are not damaged. Never stand under the hoisted product.



Never jeopardise safety by removing bolted covers, hoods or similar.



Never jeopardise safety by deactivating safety equipment.



Any work on the product's cooling system should be carried out by authorised personnel only.



The product's electrical systems should only be installed and serviced by a qualified electrician.

-If the supply cord is damaged, it must be replaced by the manufacturer, its service agent or similarly qualified persons in order to avoid a hazard.



This device can be used by children from the age of eight years and above and by people with reduced physical, sensory or mental ability or lack of experience or knowledge if they have been taught, either with supervision or with the instructions provided, how to use the device safely and understand the risks involved. Children should not play with the device. Cleaning and maintenance should not be carried out by children without supervision.



If these instructions are not followed when installing, operating and maintaining the system, Enertech's commitment under the applicable warranty terms is not binding.



Information in this type of box [!] is particularly important for correctly installing and using the product.

Congratulations on buying your new product



The complete outdoor air source heat pump

The CTC EcoAir 400 is an outdoor air source heat pump which moves heat from the outside air and delivers it to the heating system of the building. The CTC EcoAir 400 works with outside air temperatures down to -22°C .

The heat pump can be connected to the CTC EcoZenith or to the existing boiler via the CTC EcoLogic PRO control system

The CTC EcoAir 400 has been designed to operate with high efficiency and low noise levels. The heat pump has integrated hot gas defrosting which keeps the evaporator coil free from ice to maintain high efficiency.

Keep this manual containing the installation and maintenance instructions. If the heat pump is properly maintained, you will be able to enjoy the use of your CTC EcoAir 400 for many years. This manual will provide all the information you will need.

Checklist

The check list must be completed by the installer.

- If service is needed, you may be required to provide this document.
- Installation must always be in accordance with the installation and maintenance instructions.
- Installation must always be carried out by an MCS accredited installer.

Following installation, the unit must be inspected and functional checks performed as indicated below:

Pipe installation

- Heat pump filled, positioned and adjusted in the correct manner according to the instructions.
- Heat pump positioned so that it can be serviced.
- Capacity of the charge/radiator pump (depending on type of system) for the flow required.
- Open radiator valves (depending on type of system) and other relevant valves.
- Tightness test
- Bleed the system
- Check proper operation of the requisite safety valves
- Action taken to deal with condensation water

Electrical installation

- Power switch
- Correct tight wiring
- Requisite sensors fitted.
- Accessories

Information for the customer (adapted to current installation)

- Start-up with customer/installer
- Menus/controls for selected system
- Installation and maintenance manual supplied to the customer
- Checks and filling, heating system
- Information on fine adjustments
- Alarm information
- Functional test of safety valves fitted
- Guarantee and insurance
- Information on procedures for fault registration

Date / Customer

Date / Installer

1. Technical data

1.1 Table 400V 3N~

CTC EcoAir 400		406	408
Electrical data		400V 3N~ 50 Hz	
Output power ¹⁾	kW	6.2/4.8/3.8	7.8/6.0/4.7
Input power ¹⁾	kW	1.3/1.3/1.2	1.6/1.6/1.6
COP ¹⁾		4.78/3.69/3.10	4.83/3.76/3.02
Rated current ²⁾	A	4.0	4.9
Max starting current	A	16.4	17.4
Water volume	liter	1.9	2.4
Refrigerant quantity (R407C, fluorinated greenhouse gases GWP 1774)	kg	2.2	2.2
CO ₂ equivalent	ton	3.902	3.902
Break value pressure switches HT	bar	31	
Max. operating pressure water (PS)	bar	2.5	
Dimensions (Depth x Width x Height)	mm	545 x 1245 x 1080	
Compressor / Oil type		Scroll / PVE FV50S	
Air volume	m ³ /h	2500	2800
Fan speed	rpm	463	527
Fan input power	W	25	37
Weight	kg	120	126
Heat pump Keymark Cert. No.		012-056	012-057

¹⁾ at 35°C water temp. and +7/+2/-7 air temp.

²⁾ Incl. charge pump Stratos Tec 25/7 or Grundfos UPM GEO 25-85

CTC EcoAir 400		410	415	420
Electrical data		400V 3N~ 50 Hz		
Output power ¹⁾	kW	11.5/8.8/7.3	15.9/12.0/10.0	17.6/13.9/11.5
Input power ¹⁾	kW	2.4/2.3/2.3	3.5/3.4/3.3	4.1/3.9/3.9
COP ¹⁾		4.86/3.83/3.19	4.76/3.57/3.03	4.62/3.54/3.02
Rated current ²⁾	A	7.5	10.0	11.8
Max starting current	A	21.6	29.6	33.5
Water volume	liter	2.8	3.9	4.5
Refrigerant quantity (R407C, fluorinated greenhouse gases GWP 1774)	kg	2.7	3.4	3.5
CO ₂ equivalent	ton	4.789	6.031 ³⁾	6.209 ³⁾
Break value pressure switches HT	bar	31		
Max. operating pressure water (PS)	bar	2.5		
Dimensions (Depth x Width x Height)	mm	610 x 1375 x 1180		
Compressor type / Oil type		Scroll / PVE FV50S		
Air volume (low speed/high speed)	m ³ /h	4100	4000/5400	5400/6200
Fan speed (low speed/high speed)	rpm	489	480/650	650/715
Fan input power	W	60	140	170
Weight	kg	180	187	190
Heat pump Keymark Cert. No.		012-058	012-059	012-060

¹⁾ at 35°C water temp. and +7/+2/-7 air temp.

²⁾ Incl. charge pump Stratos Tec 25/7 or Grundfos UPM GEO 25-85

³⁾ hermetically sealed equipment¹⁾

No annual leakage control of the refrigerant is required

1.2 Table 230 V 1N~

CTC EcoAir 400		406	408	410
Electrical data		230V 1N~ 50 Hz		
Output power ¹⁾	kW	6.2/4.7/3.7	7.7/6.0/4.8	11.6/8.9/7.1
Input power ¹⁾	kW	1.3/1.3/1.3	1.7/1.6/1.6	2.5/2.4/2.3
COP ¹⁾		4.59/3.53/2.87	4.64/3.62/2,97	4.86/3.65/3.03
Rated current ²⁾	A	10.3	12.4	18.8
Max starting current	A	22.8	23.2	23.5
Max. system impedance	Ohm	0.418	0.413	0.408
Water volume	liter	1.9	2.4	2.8
Refrigerant quantity (R407C, fluorinated greenhouse gases GWP 1774)	kg	2.2	2.2	2.7
CO ² equivalent	ton	3,902	3,902	4,789
Break value pressure switches HT	bar	31		
Max. operating pressure water (PS)	bar	2.5		
Dimensions (Depth x Width x Height)	mm	545x1245x1080		610x1375x1180
Compressor / Oil type		Scroll / PVE FV50S		
Air volume	m ³ /h	2500	2800	4100
Fan speed	rpm	463	527	493
Fan input power	W	25	37	60
Weight	kg	120	126	201/180
Heat pump Keymark Cert. No.		012-056	012-057	012-058

¹⁾ at 35°C water temp. and +7/+2/-7 air temp.

²⁾ incl. charge pump Stratos Tec 25/7 or Grundfos UPM GEO 25-85
No annual leakage control of the refrigerant is required

! Note: In case of deviations, the product's data plate applies. When servicing always check the product's data plate for correct refrigerant quantity.

1.3 Dimensional drawing

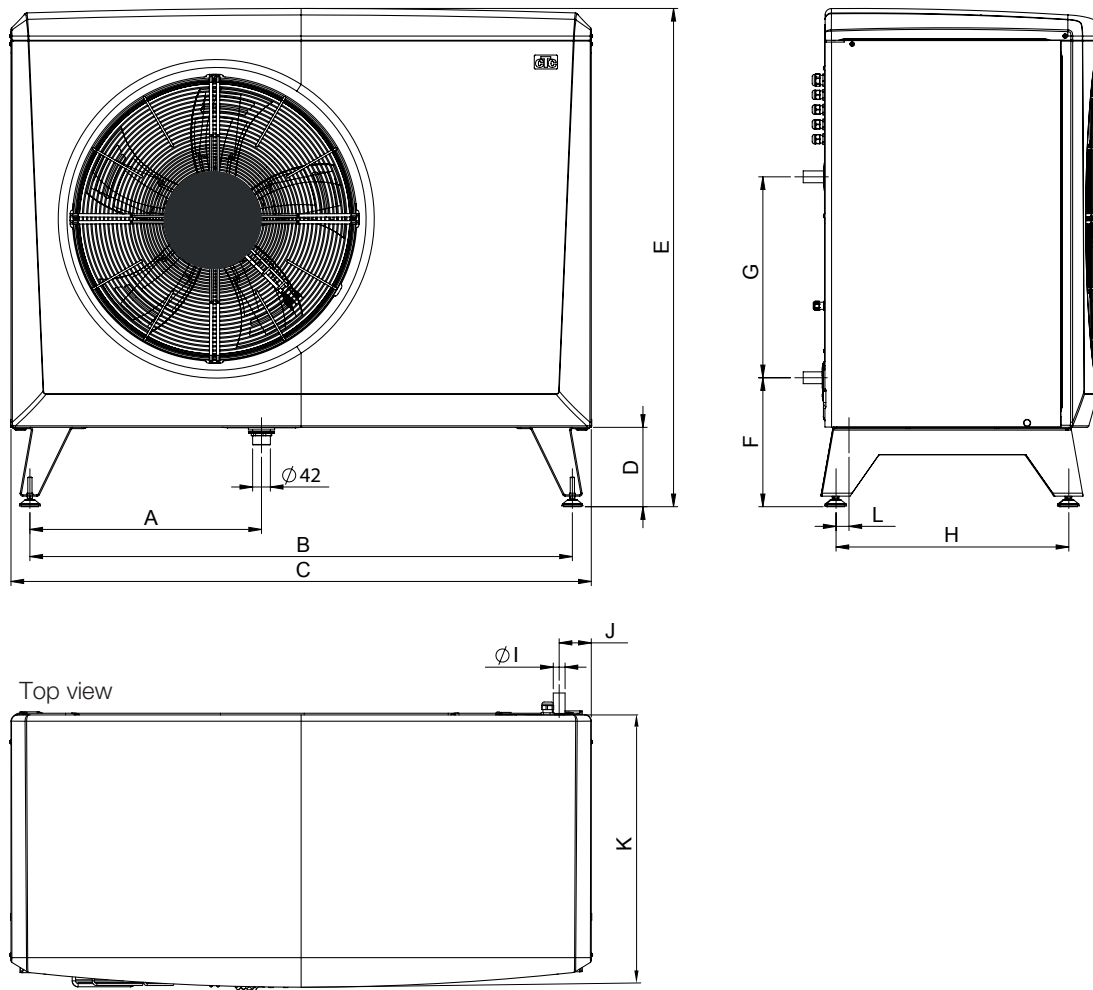

	CTC EcoAir 406, 408	CTC EcoAir 410-420
A	486	550
B	1155	1285
C	1245	1375
D	188	188
E	1080	1180
F	308	308
G	476	476
H	451	551
I	$\varnothing 28$	$\varnothing 28$
J	85	83
K	545	645
L	10	33

1.4 Refrigerant system

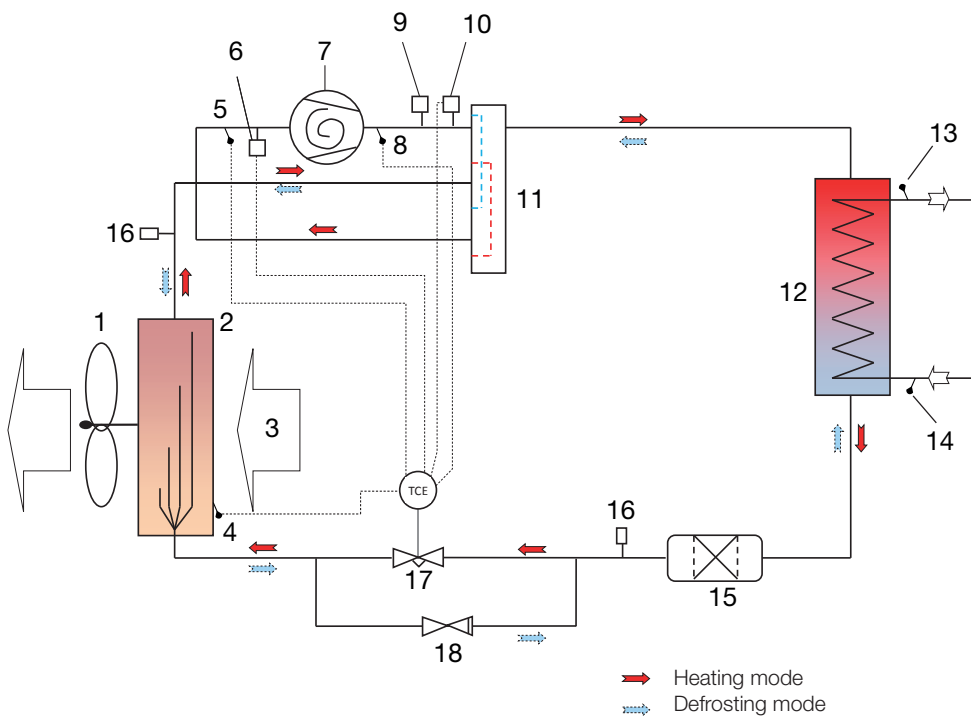

1. Fan
2. Evaporator
3. Air
4. Defrosting sensor (B16)
5. Suctiongassensor (B22)
6. Low pressure sensor (B101)
7. Compressor
8. Hot gas sensor (B21)
9. High pressure switch
10. High pressure sensor (B100)
11. 4-way valve
12. Condenser
13. Primary flow sensor (B1)
14. Return sensor (B7)
15. Drying filter
16. Schrader
17. Expansion valve
18. Non-return valve

Heating mode
 Defrosting mode

1.5 Component location

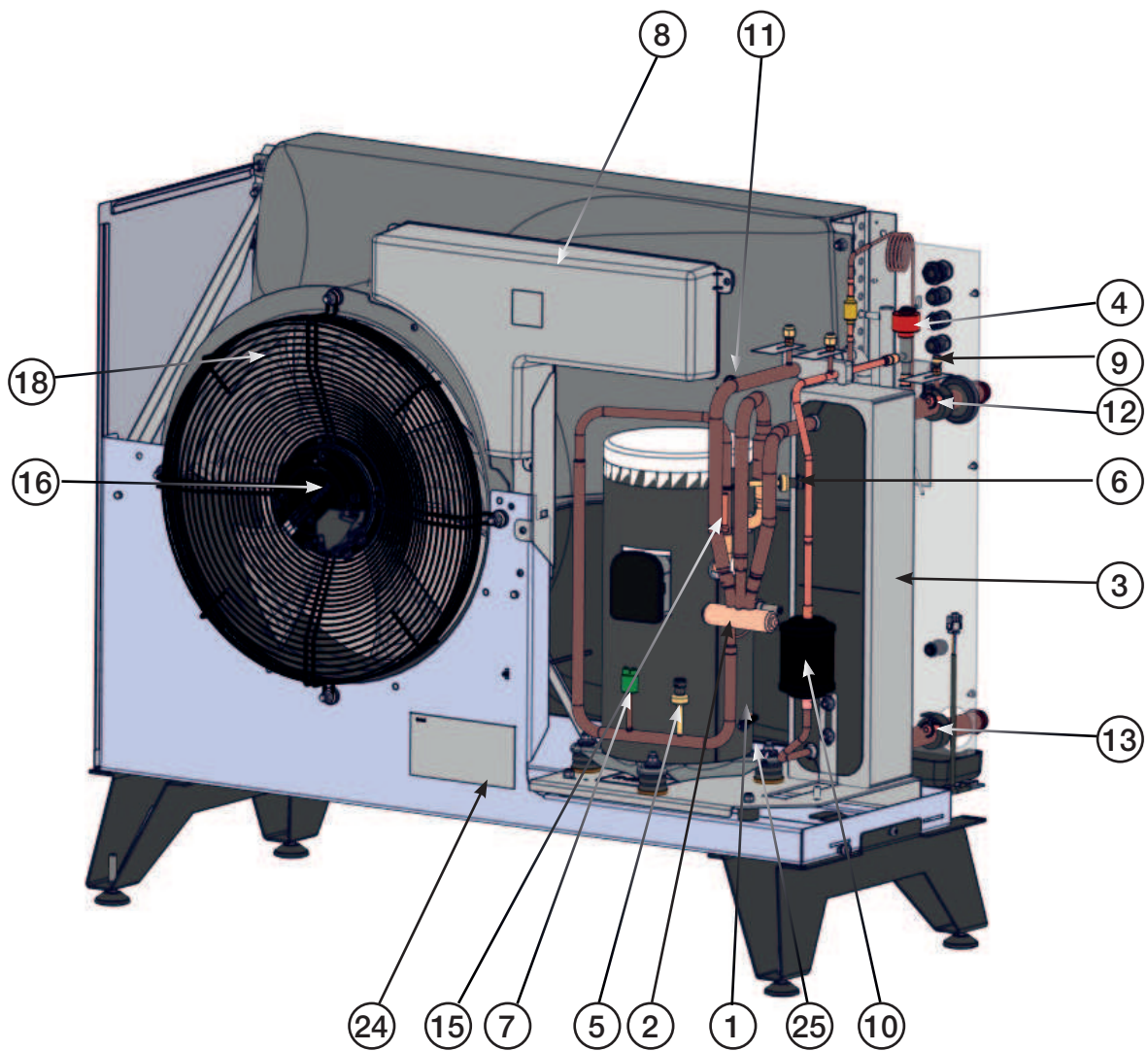

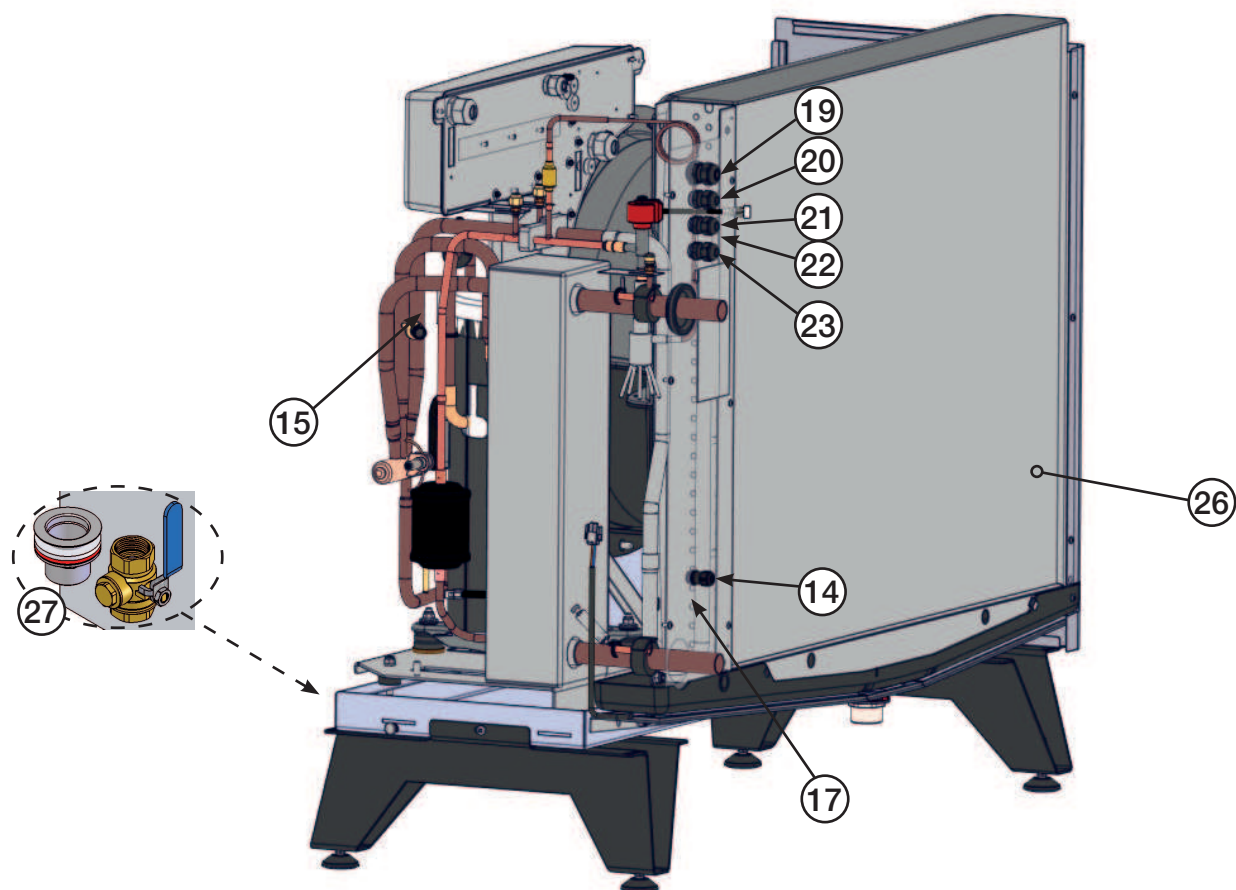

- | | |
|--------------------------|--|
| 1. Compressor | 16. Fan |
| 2. 4-way valve | 17. Defrosting sensor in evaporator |
| 3. Condenser | 18. Fan sensor |
| 4. Expansion valve | 19. Power supply |
| 5. High pressure sensor | 20. Communication product |
| 6. Low pressure sensor | 21. Communication, series connection |
| 7. High pressure switch | 22. Power supply, circulation pump |
| 8. Connection box | 23. Communication, circulation pump |
| 9. Bleeding nipple/water | 24. Type plate with serial number etc. |
| 10. Drying filter | 25. Compressor heater |
| 11. Suction gas sensor | 26. Evaporator |
| 12. Primary flow sensor | 27. Packaged components (filter ball valve and condensate drain) in cardboard box under product on pallet. |
| 13. Return sensor | |
| 14. Outdoor sensor | |
| 15. Hot gas sensor | |

2. Connection alternative CTC EcoAir 400

2.1 General

The illustration below shows the different connection alternatives available for the CTC EcoAir 400. In some cases, a CTC Converter or CTC Basic display may be needed. See the chapter on Connecting the control system.

Alternative A

The CTC EcoAir 400 can be connected to the products below.

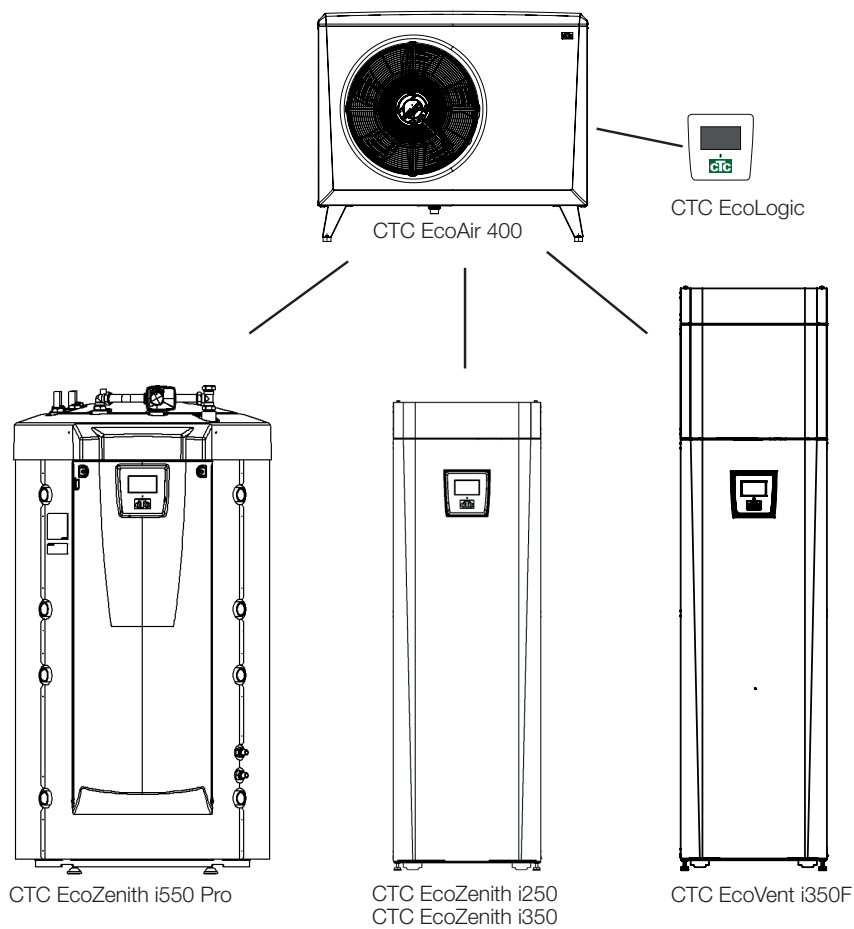

! CTC EcoZenith i250 can be connected to products with an output up to 11 kW.

! Older products (version 3) must use the CTC Converter as an interpreter to control the CTC EcoAir 400.

3. Important to remember!

Check the following points in particular at the time of delivery and installation:

2.2 Transportation

- The product must be transported and stored in an upright position. Transport the unit to the installation site before removing the packaging.
- Remove the packaging and check before installation that the product has not been damaged in transit. Report any transport damage to the carrier.
- Handle the product with a forklift if possible, or lifting straps around the pallet, NOTE! Can only be used with the packaging on.

2.3 Positioning

- Place the product on a solid foundation. See chapter 'Placement of the heat pump'.
- Flexible hoses should be installed closest to the heat pump. Outdoor pipes should be thoroughly insulated with weather-proof insulation.
- Ensure that pipes used between the heat pump and the heating system are of adequate dimensions.
- Ensure that the circulation pump has sufficient capacity to pump the water to the heat pump.

2.4 Recycling

- The packaging must be deposited at a recycling station or with the installation engineer for correct waste management.
- At the end of the product's life cycle, it must be recycled in a correct way and be transported to a waste station or reseller offering a service of that type. Disposing of the product as household waste is not permitted.
- It is of great importance that the product's refrigerant, compressor oil and electrical/electronic equipment are properly disposed of.

2.5 After commissioning

- The installation engineer advises the property owner on the construction and servicing of the system.
- The installation engineer fills in a checklist and contact information – the customer and installation engineer sign the list, which the customer keeps.

4. Installation

This chapter is aimed at anyone responsible for one or more of the installations required to ensure that the product works the way the property owner wants.

Take your time going through functions and settings with the property owner and answer any questions. Both you and the heat pump benefit from a user who has completely understood how the system operates and should be maintained.

The installation must be carried out in accordance with current MCS standards. Refer to MIS 3005 and associated building regs Part L,F & G. The product must be connected to an expansion vessel in an open or closed system. **Do not forget to flush the radiator system clean before connection.**

! The product must be transported and stored in an upright position.

The heat pump operates with a primary flow/return temperature across the condenser of up to 65/58 °C.

Transportation

Transport the unit to the installation site before removing the packaging. Handle the product in the following manner:

- Forklift
- Lifting band around the pallet. **NB:** Can only be used with the packaging on.

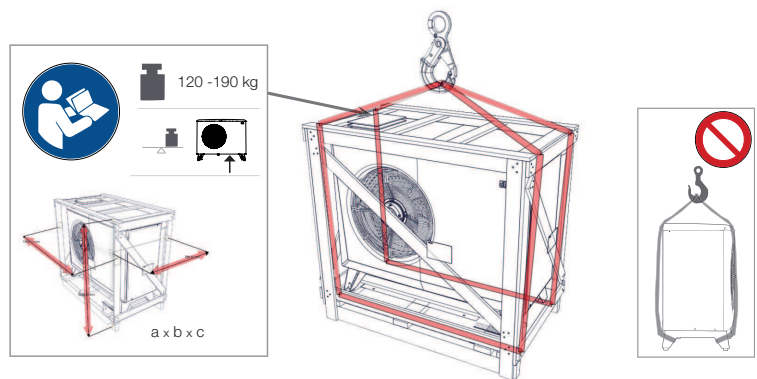

Unpacking

Unpack the heat pump when it is placed next to its installation site. Check that the product has not been damaged in transit. Report any transport damage to the carrier. Also check that the delivery is complete according to the list below.

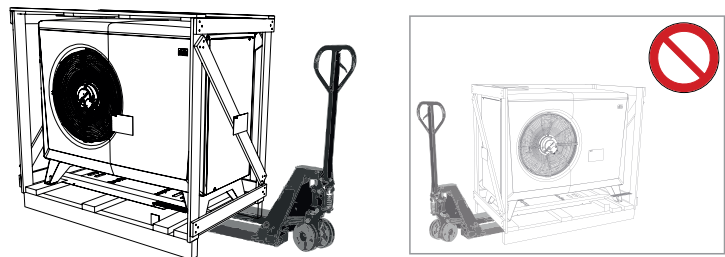

Delivery includes

- 1 x CTC EcoAir 400 heat pump
- Packaged components (see chapter titled 'Component Location')
 - filter ball valve: G1" (EcoAir 406-410), G1½" (EcoAir 415-420)
 - condensate drain: G1¼"
- 15 m LIYCY (TP 2x2x0,75 mm²) cable with connector for communication, fitted.
- 2 m power cable, fitted:

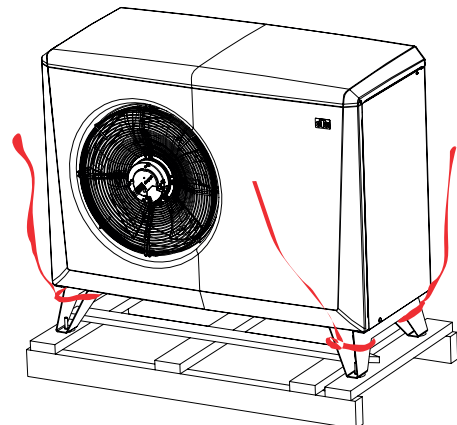

EcoAir 406-410	3x400V	5G x 1,5 mm²
EcoAir 415-420	3x400V	5G x 2,5 mm²
EcoAir 406-410	1x230V	3G x 4 mm²

5. Placement of the heat pump

Place the heat pump so that noise from the compressor and fan does not disturb the surroundings. Do not place the heat pump right next to a bedroom window, patio or fence.

- CTC EcoAir 400 is normally placed on an outside wall.
- There should be a space of at least 250 mm (EcoAir 406-410) or 400 mm (EcoAir 415-420) between the product and the wall so that outdoor air can pass freely in through the evaporator.
- If the heat pump is placed in a corner, there should be a space of at least 250 mm between the side of the heat pump and the wall.
- Allow a space of at least 2 metres between the heat pump and any bushes etc.
- Take the distance to the nearest neighbour into account by checking the noise data in the “noise data” chapter.
- The recommended distance between units is 400 mm.
- The legs of the CTC EcoAir must stand stably on concrete blocks or similar.
- Use a spirit level to adjust the unit, so that it is completely level.
- Due to the design of the stand and the weight of the pump, it is not necessary to secure the unit to the ground or the wall.

Installing the heat pump in a sheltered spot is inadvisable, and so is placing it in an outhouse or car port, because the air should flow as freely as possible through the heat pump and used air should not to be sucked into the inlet on the back. This can cause abnormal ice formation in the evaporator. If the product is in an exposed location, with extra harsh weather conditions, then a suitable covering or sheltered location is justified.



These guidelines must be followed in order for your CTC EcoAir 400 to give the best performance.

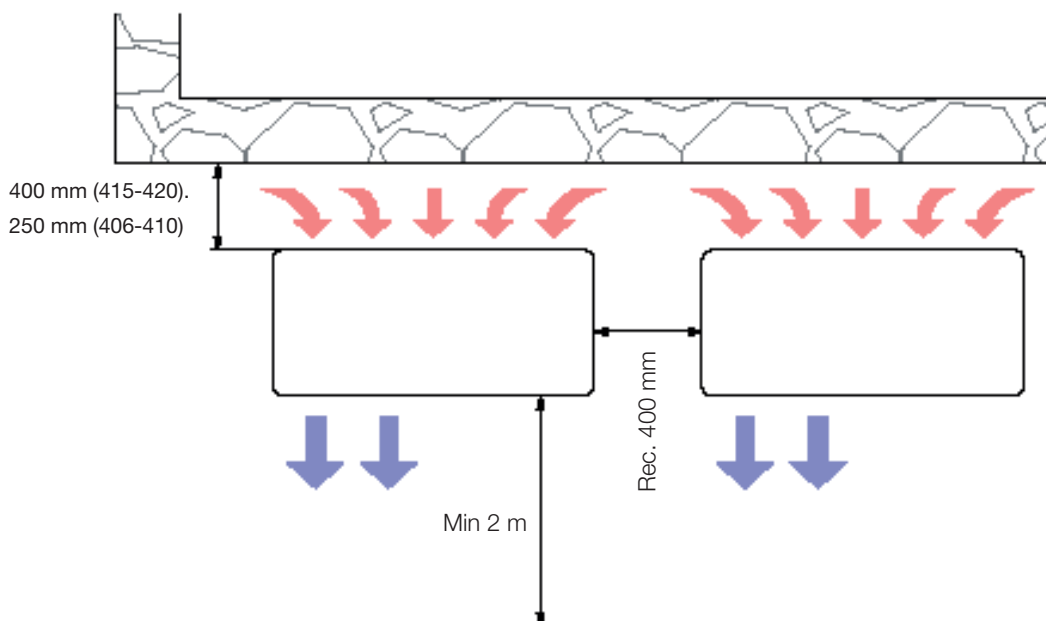

6. Preparation and drainage

The heat pump should be positioned so that the house cannot be damaged and the condensation water can easily drain into the ground. The foundation should be of concrete blocks or similar, resting on crushed stones or gravel.

- Make a 'stone curb' under the heat pump. Remember that there may be up to 70 litres of condensation water a day under some conditions, from the largest model.
- Make a 70 – 100 cm deep hole.
- Place a moisture barrier in the hole on the side against the foundations of the building
- Half fill the hole with crushed stones and lay concrete blocks or similar.
- Mark up the c/c dimension (1155/1285 mm) between the blocks to match the span of the heat pump stand.

*c/c distance	CTC EcoAir 406-408	CTC EcoAir 410-420
length (depth) mm	1155 (451)	1285 (551)

- Use a spirit level to ensure that the blocks are level.
- Place crushed stones around the blocks to achieve optimal drainage.

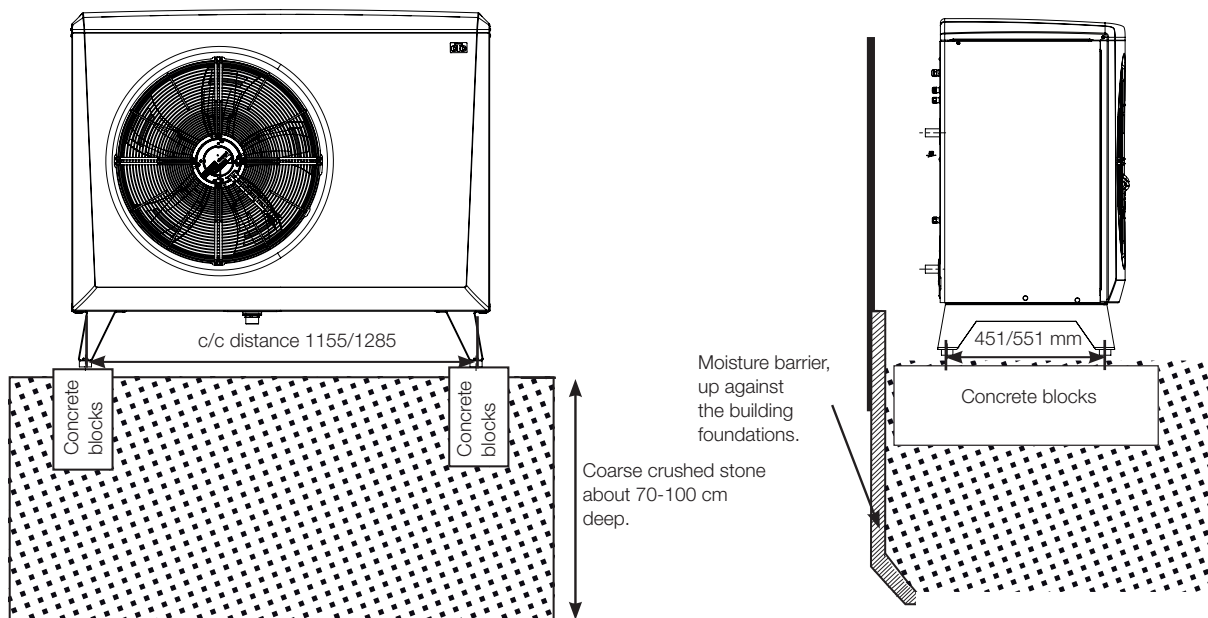

6.1 Condensation water

- The condensation tray is built into the heat pump and is used to divert most of the condensation water. The tray can be connected to a suitable drain. Connection diameter: 42 mm.
- A heating cable (available as an accessory) should be placed in the pipe to prevent refreezing. The heating cable is connected to the electrical cabinet in the CTC EcoAir 400 (to be performed by an authorised electrician and according to applicable provisions.)
- If the house has a cellar, it is advisable to route the condensation water to a floor drain indoors (to be performed according to the applicable rules). The pipe should be installed with a slope towards the house and above the ground (so no other water can get into the cellar). Wall apertures should be sealed and insulated. A water trap must be connected to the inside to prevent air from circulating in the pipe.
- If there is a stone curb, the outlet from the condensation water pipe should be placed at a frost-free depth.
- The condensation water may also be routed into the house drains, e.g. from the downpipes. Here a heating cable must be placed in the pipes that are not frost-free.

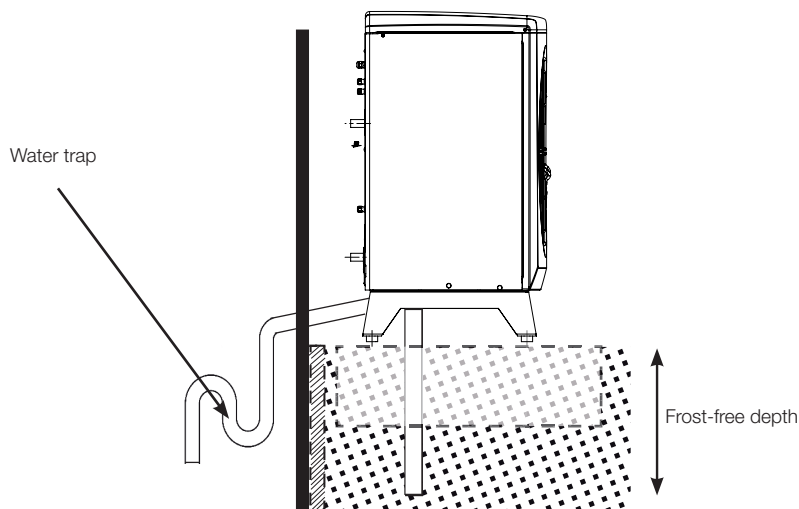

7. Pipe installation

The installation must be carried out in accordance with current MCS standards. Refer to MIS 3005 and associated building regs Part L,F & G. The boiler must be connected to an expansion vessel in an open or closed system. Do not forget to flush the radiator system clean before connection.

7.1 Pipe connection

- Return lines of at least 22 mm (for 406-410) and 28 mm (for 415-420) copper pipe are connected to the heat pump. For longer pipes, the installer should calculate the pump and pipe dimensions needed to handle the minimum recommended flow for the CTC EcoAir 400 concerned.
- Route the pipes between the heat pump and the boiler without any highest points. If this cannot be done, provide this highest point with an automatic air separator or and in line aerator.
- The connection to the heat pump should be made with a wire-reinforced diffusion-tight hose for hot water, min. 1" diameter. Recommended hose length 1000 mm, to prevent noise from the heat pump spreading into the house and to take up any movement of the heat pump
- Pipes installed outside should be insulated with at least 13 mm thick insulation which is not sensitive to water. Ensure that the insulation is sealed tightly everywhere and that joints are thoroughly taped or glued.
- Indoor pipes should be insulated as far as the boiler with at least 9 mm thick insulation. This is to enable the heap pump to deliver the highest possible temperature to the boiler or tank without any losses.
- The product can be bled via the bleed valve inside the condenser.

! Do not forget to flush the radiator system clean before connection.

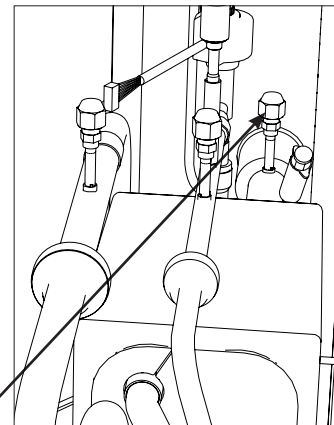

! NOTE! Bleed only on this valve. The others are for the cooling system, If these are opened, refrigerant can leak!

Pressure differential diagram for CTC EcoAir 400

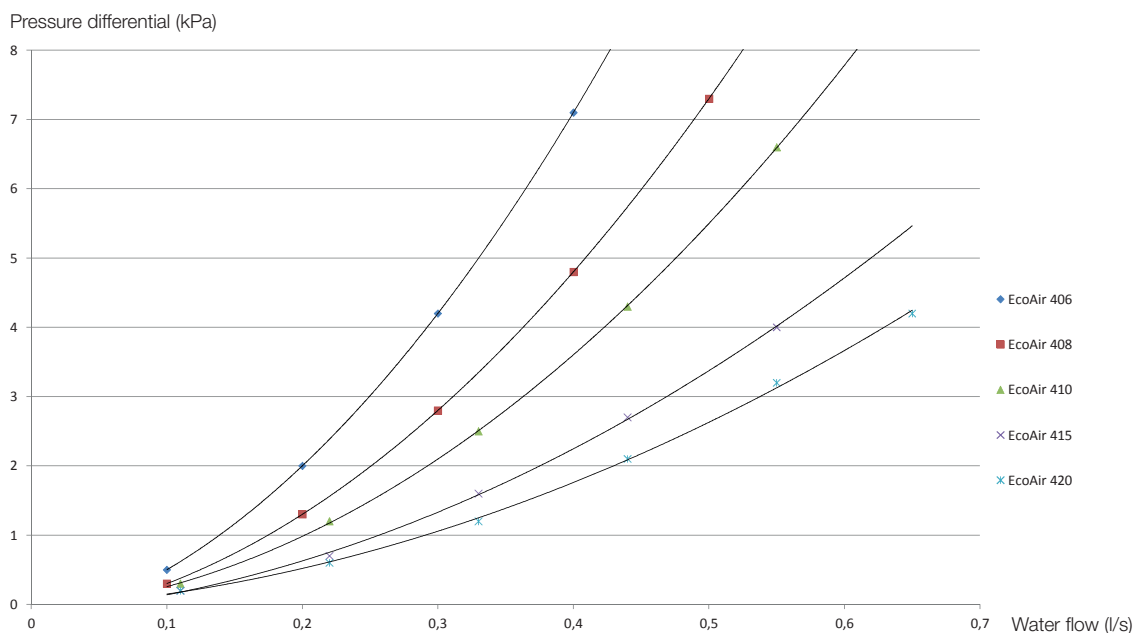

7.2 Example pipe connection

EcoAir/EcoZenith i350 L

The CTC EcoZenith i350 L has pipes at the rear right edge for connection of the heat pump. The heat pump's lower connection is connected to the right connection when viewed from the front, so that water is pumped out to the heat pump. The heat pump's upper connection is thus connected to the left connection.

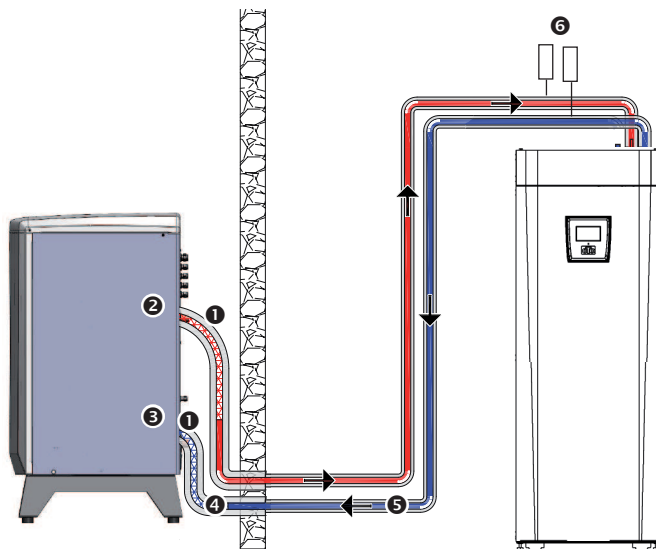

1. Wire-reinforced diffusion-tight hose for hot water, min. 1". Hose length 1000 mm from the unit.
2. Outgoing (heated) water Ø28 mm connection on the condenser.
3. Incoming (cold) water Ø28 mm connection on the condenser.
4. Minimum Ø22 copper pipe. Insulated outside with 13 mm thick insulation.
5. Inside piping is insulated with 9 mm thick insulation.
6. Bleeder

EcoAir/EcoZenith i350 H

On the CTC EcoZenith i350 H, the heat pump is connected directly to the charge pump located under the tank. The heat pump's lower connection must be connected to the charge pump so that water is pumped out to the heat pump. The heat pump's upper connection is connected to the right diverting valve by the charge pump.



For optimum performance insulate outdoor and indoor piping as recommended in the instructions.

8. Circulation pump

The choice of circulation pump depends on the type of system. Ensure that the circulation pump is large enough, so that there is sufficient flow through the heat pump. The circulation pump may be connected either internally within the CTC EcoAir 400 or externally in the controlling unit.

The charge pump supplies the CTC EcoAir 400 with water. If the outdoor temperature is below + 2 °C the charge pump runs constantly to eliminate any risk of freezing.

Internal connection.

With internal connection, the flow through the circulation pump is controlled by the controller in the CTC EcoAir 400. The control system for the CTC EcoAir 400 monitors and ensures that the unit is working within its operating range. For optimum performance, choose one of the A-class circulation pumps below.

CTC EcoAir 406-408	Yonos Para PWM 7,0	Item no 586396 303
CTC EcoAir 410	Yonos Para PWM 7,5	Item no 586396 302
CTC EcoAir 415-420	UPM GEO 25-85	Item no 586396 301

External connection

With external connection, a circulation pump is installed so that the right flow through the heat pump can be guaranteed.

Set the right temperature differential by adjusting the speed of the circulation pump.

This is to ensure that the right differential for the current outdoor temperature is produced according to the table.

Outdoor temp. (°C)		-10	-5	0	+5	+7	+10
CTC EcoAir 406	Primary flow 35 °C Flow = 0.21 l/s	4°C	4,5°C	5,5 °C	6,5 °C	7 °C	8°C
CTC EcoAir 408	Primary flow 35 °C Flow = 0,27 l/s	4°C	4,5°C	5,5 °C	6,5°C	7 °C	7,5°C
CTC EcoAir 410	Primary flow 35 °C Flow = 0.39 l/s	4°C	5°C	6°C	6.5°C	7 °C	8°C
CTC EcoAir 415	Primary flow 35 °C Flow = 0.55 l/s	4°C	4.5°C	5.5°C	6.5°C	7 °C	7.5°C
CTC EcoAir 420	Primary flow 35 °C Flow = 0.64 l/s	4°C	4.5°C	5.5°C	6.5°C	7 °C	7.5°C

In some systems with EcoLogic, the entire radiator flow must go through the heat pump, so the pump must be sized according to the flow of the whole system. For safe operation, the following flow must be maintained:

CTC EcoAir 406: 760 l/tim

CTC EcoAir 408: 960 l/tim

CTC EcoAir 410: 1400 l/hr

CTC EcoAir 415: 2000 l/hr

CTC EcoAir 420: 2300 l/hr

This provides about: 7 °C temperature differential with an outside temperature of +7 °C and a primary flow temperature of 35 °C

8.1 Control/supply

CTC EcoZenith i550 Pro

The circulation pump is controlled and powered from the CTC EcoZenith i550Pro. For more information, see the relevant product manual.

CTC EcoZenith i250, CTC EcoZenith i350, CTC EcoVent i350F

The circulation pump is factory-installed in the CTC EcoZenith i250. Control and supply take place from the product. For more information, see the relevant product manual.

CTC EcoLogic PRO

Up to 10 heat pumps can be connected to a CTC EcoLogic PRO. The circulation pumps in heat pumps 1 and 2 can then be connected to the CTC EcoLogic PRO. The circulation pumps for heat pumps 3-10 should be connected to the CTC EcoAir 400.

CTC EcoLogic v3

The circulation pump (not speed-controlled) is controlled and powered from the CTC EcoAir 400.

CTC EcoZenith v3

The circulation pump (not speed-controlled) is controlled and powered from the CTC EcoAir 400.

CTC EcoEI v3

The circulation pump (not speed-controlled) is controlled and powered from the CTC EcoAir 400.

8.2 Operating range

The control system for the CTC EcoAir 400 monitors and ensures that the unit is working within its operating range.

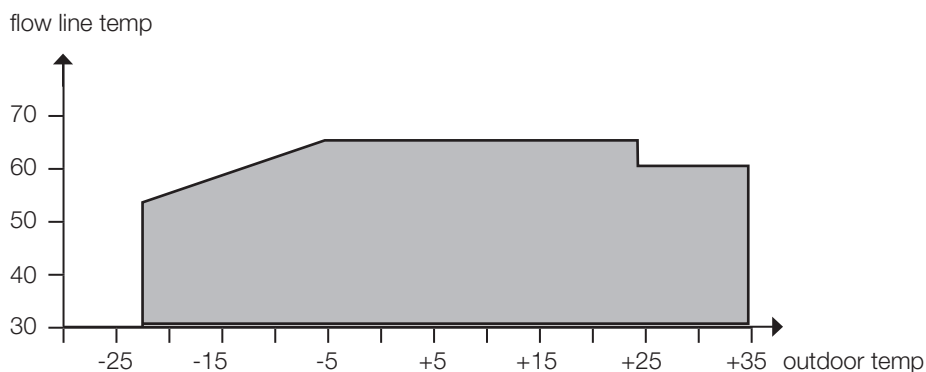

9. Electrical installation

The installation and heat pump connection must be done by an authorised electrician. All wiring must be installed according to valid requirements.

9.1 Electrical installation 400V 3N~

Supply, black connector

The CTC EcoAir 400 must be connected to 400V 3N~ 50 Hz and protective earth. The minimum group fuse size is specified in 'Technical data'.

The 2 m long power supply cable is pre-connected to the product.

9.2 Electrical installation 230V 1N~

Supply, black connector

The CTC EcoAir 400 must be connected to 230V 1N~ 50 Hz and protective earth. The minimum group fuse size is specified in 'Technical data'.

The 2 m long power supply cable is pre-connected to the product.

9.3 Safety switch

The installation should be preceded by a dual pole isolating safety switch which ensures disconnection from all electric power sources.

9.4 Alarm output

The CTC EcoAir 400 is fitted with a potential-free alarm output which is activated if any alarm is active in the heat pump. This output may be connected to a maximum load of 1 A 250 V AC. An external fuse should also be used. Cable approved for 230 V AC must be used for connecting this output, irrespective of the load that is connected. For connection information, see the wiring diagram.

9.4.1 Termination one heat pump

When installing 1 heat pump, dip-switch 2 should be set to the ON position.

Detailed view from wiring diagram.

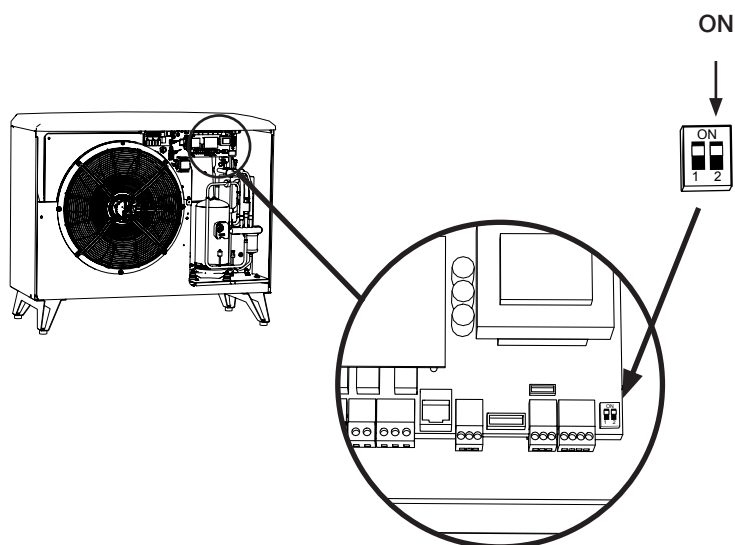

9.4.2 Termination for connection of heat pumps in series

In a series connection dip switch 2 must be turned OFF on all heat pumps except the last one, which should be set to the ON position..

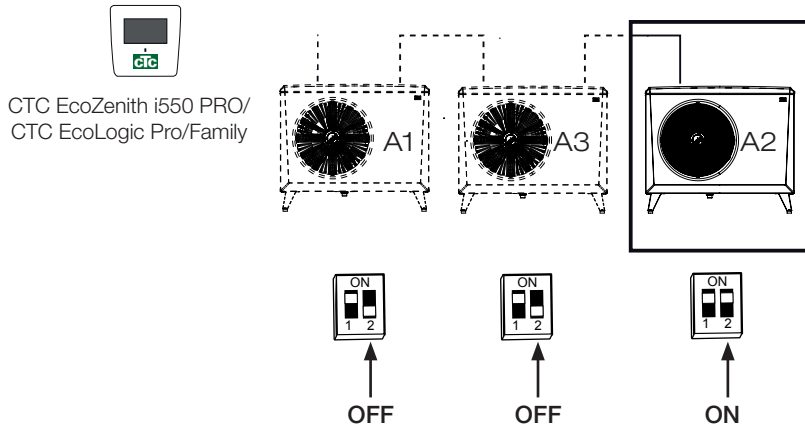

! When connected in series, the last heat pump must be set to the terminated position. Read more under the chapter Electrical installation/ Terminated position

9.4.3 Heatpump in series - address

When connecting more than one heat pump to a CTC EcoLogic Pro or CTC EcoZenith 550 Pro, the CTC Basic Display accessory must be used to address the various heat pumps A1, A2, A3, etc. All CTC EcoAir 400 units are factory-set addressed to A1. For connection, see the manual for the CTC Basic Display. Recommended cable between products LIYCY (TP).



CTC Basic Display (accessory)

9.4.4 Connection CTC Basic Display

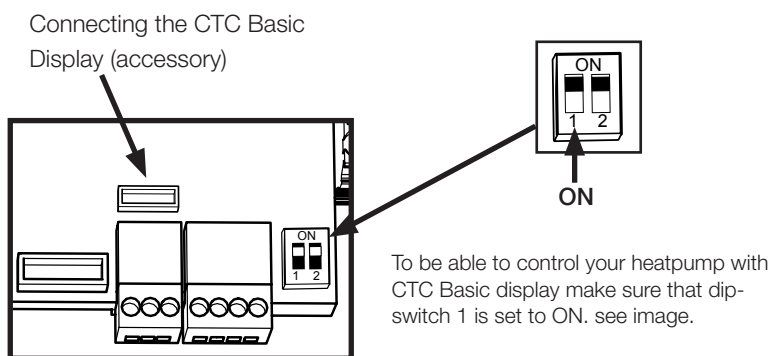

Heat pumps connected in series

CTC Basic Display

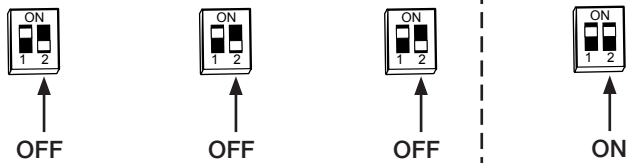
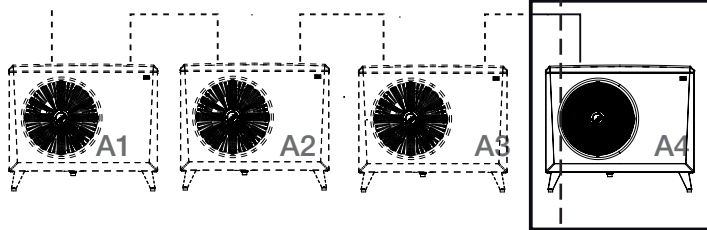

B A G Sc

Shielding
Green
White
Brown

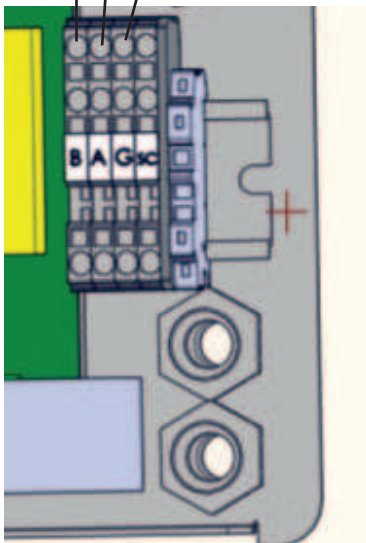

Connect each cable to the next heat pump in the series connection here.

Remove the loop(PE); connect the shielding to the next heat pump here.

B A G Sc

Shielding
Green
White
Brown

PE

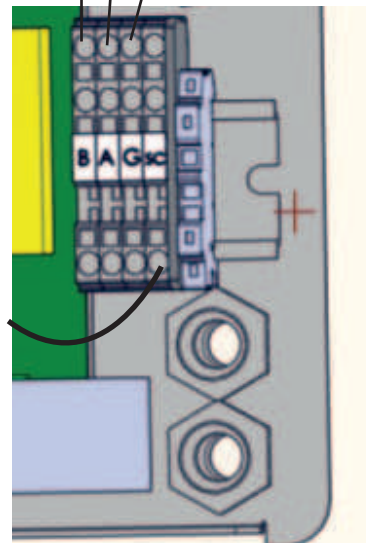

Make sure DIP switch 2 is in the ON position on the last heat pump in the series connection.

The loop(PE) should be left in place.

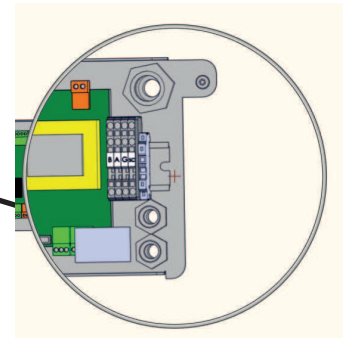
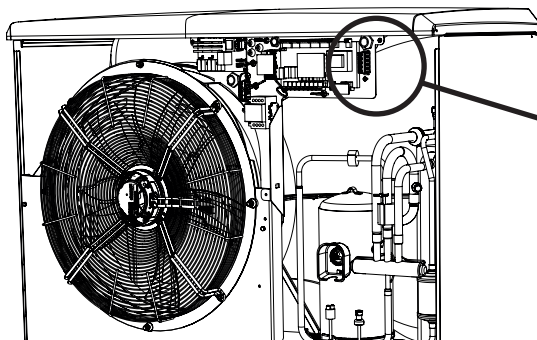

10. Connecting the control system

10.1 General

When connecting the CTC EcoAir 400 to products with different control systems, accessories are sometimes needed to control the products. The various alternatives available are described in this section.

10.2 Connection alternative 1, one heatpump

CTC EcoZenith i250, CTC EcoZenith i550 Pro, CTC EcoZenith i350, CTC EcoVent i350F

When connecting a CTC EcoAir 400 to a CTC EcoZenith i250, CTC EcoZenith i550 Pro, CTC EcoZenith i350, CTC EcoVent i350F and CTC EcoLogic Pro the communication cable (LiYCY (TP)) is connected directly to each product.

! When connected in series, the last heat pump must be set to the terminated position. Read more under the chapter Electrical installation/ Terminated position

10.3 Connection alternative 2, heatpumps in series.

CTC EcoLogic Pro/Family eller CTC EcoZenith i550 Pro

When connecting more than one heat pump to a CTC EcoLogic Family/Pro or CTC EcoZenith i550 Pro the CTC Basic Display accessory must be used to address the various heat pumps A1, A2, A3, etc. All CTC EcoAir 400 units are factory-set addressed to A1. For connection, see the manual for the CTC Basic Display. Recommended cable between products LiYCY (TP).

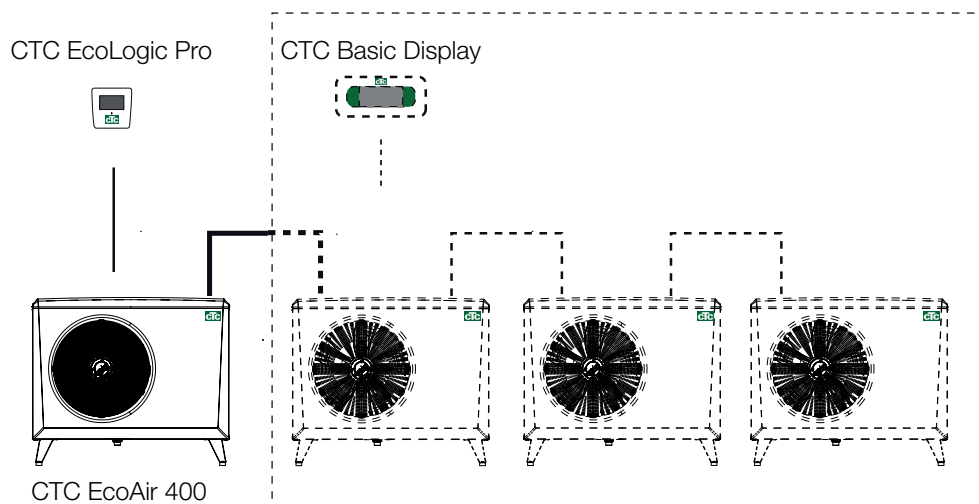

10.4 Connection alternative 3

CTC EcoEI v3

Because these products have an older control system of v3 type, the CTC Converter accessory must be used as an interpreter to control the CTC EcoAir 400. See the manual for the CTC Converter for connecting this.

! Version 3 (V3) relates to models manufactured from 2006 onwards.

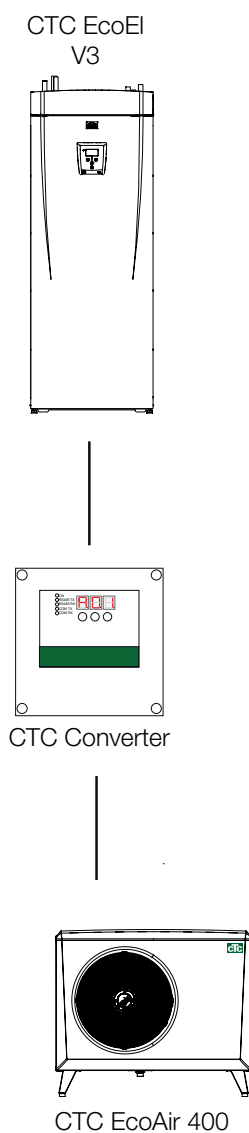

10.5 Connection alternative 4

CTC EcoZenith v3 or CTC EcoLogic v3

Because these products have an older control system of v3 type, the CTC Converter accessory must be used as an interpreter to control the CTC EcoAir 400. See the manual for the CTC Converter for connecting this.

The CTC EcoZenith version 3 is available in two different variants. An earlier variant with only one communication port, and a later one with three such ports. The earlier one will have a serial number starting from:

Prod. no.	Item no.	Model
7250-1222-0138	583700001	CTC EcoZenith I 550 3x400V
7250-1222-0168	584892001	CTC EcoZenith I 550 3x230V
7250-1222-0171	584890001	CTC EcoZenith I 550 BBR
7250-1222-0171	584893001	CTC EcoZenith I 550 1x230V

The earlier version needs a Converter to control the heat pump.

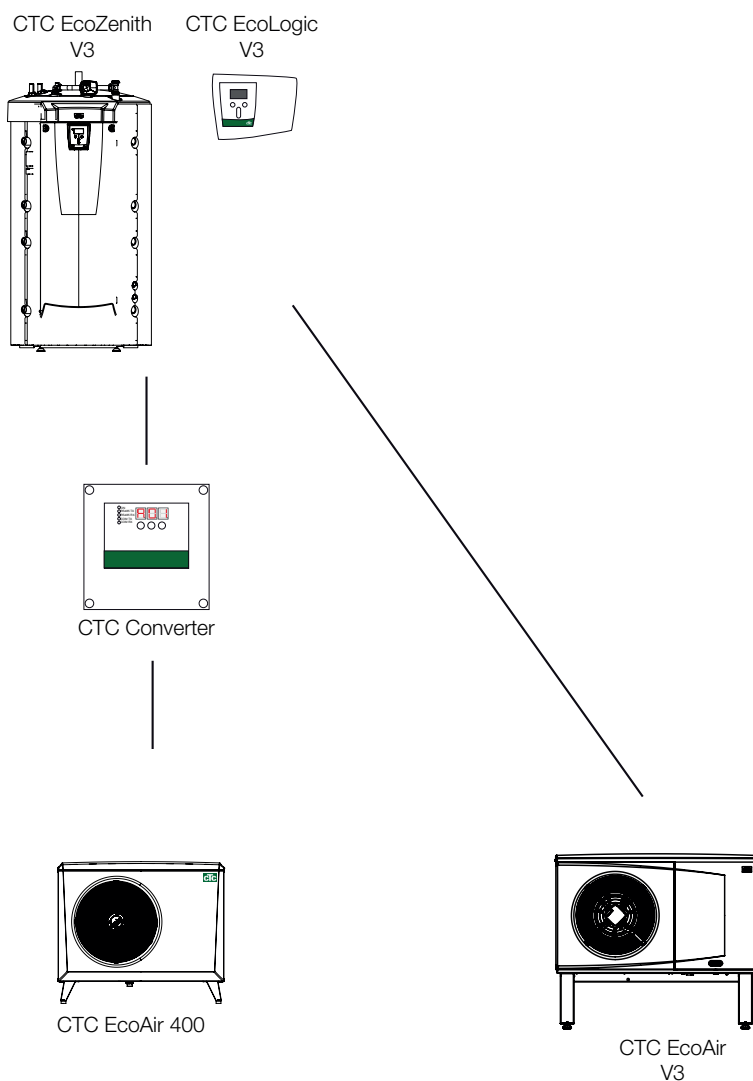

! Version 3 (V3) relates to models manufactured from 2006 onwards.

! If new (version 4) and old (version 3) heat pumps are combined in an installation, the new one must be addressed A1.

! When connected in series, the last CTC EcoAir 400 must be set to the terminated position.

10.6 Connection alternative 5

CTC EcoZenith I 550

The CTC EcoZenith version 3 is available in two different variants. An earlier variant with only one communication port, and a later one with three such ports. The later one will have a serial number starting from:

Prod. no.	Item no.	Model
7250-1222-0139	583700001	CTC EcoZenith I 550 3x400V
7250-1222-0169	584892001	CTC EcoZenith I 550 3x230V
7250-1222-0172	584890001	CTC EcoZenith I 550 BBR
7250-1222-0172	584893001	CTC EcoZenith I 550 1x230V

For the later variant a CTC Converter is needed for each version 4 heat pump.

See the manual for the CTC Converter for connection.

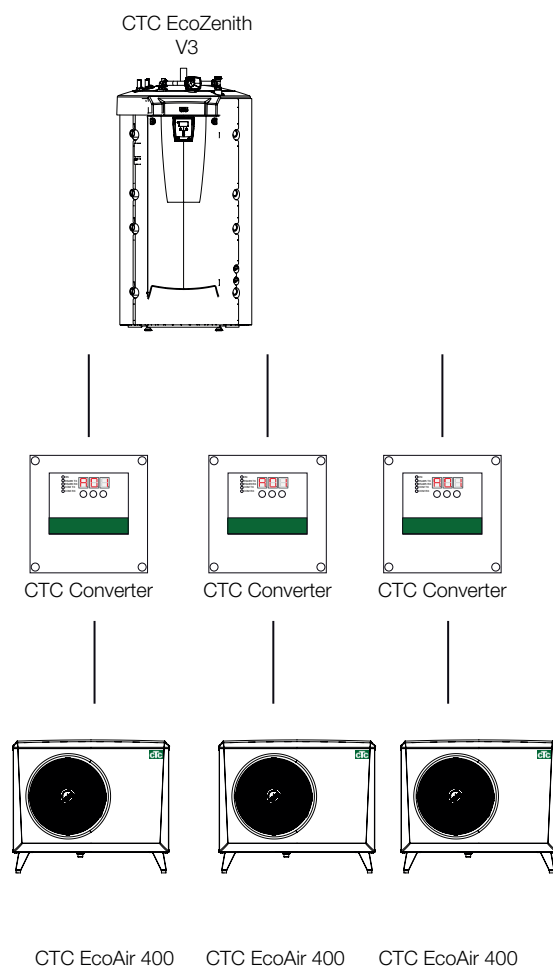

10.7 Parts list

A2	Relay/main PCB	
A4	PCB white softstarter, motorprotection and contactorfunction	
B1	Primary flow sensor	Type 2 NTC/NTC 22
B7	Return sensor	Type 2 NTC/NTC 22
B15	Outdoor sensor	Type 1 NTC/NTC 22
B16	Defrost sensor	Type 1 NTC/NTC 22
B20	Fan sensor	Type 1 NTC/NTC 22
B21	Hotgas sensor	Type 3 NTC/NTC 50
B22	Suctiongas sensor	Type 1 NTC/NTC 015
B100	Highpressure sensor	
B101	Lowpressure sensor	
C1	Capacitor compressor (1-phase)	
C2	Capacitor	
E10	Compressor heater	
E11	Vaporizer heater	
E12	Heating cable (option)	
F1	Fuse (option)	
F20	Highpressure switch	
G11	Loadpump (option)	
K1	Contactora (EA415-420)	
M1	Compressor	
M10	Fan	
X1	Terminal	
XM1	Connector supply Male	
XM2	Connector supply Female	
XC1	Connector communication Male	
XC2	Connector communication Female	
Y10	Expansion valve	
Y11	Solenoid valve	

10.8 Wiring diagram 400 V 3N~

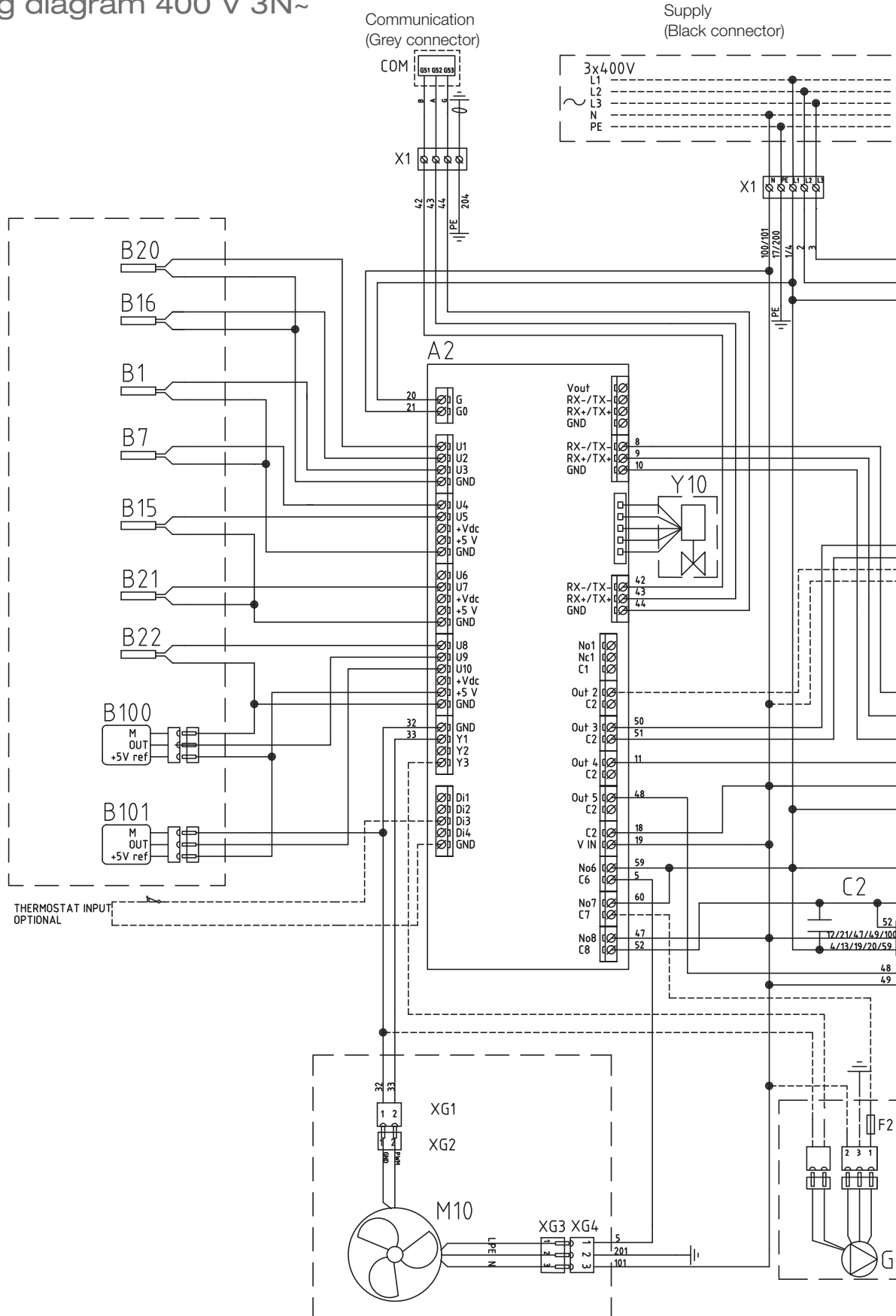

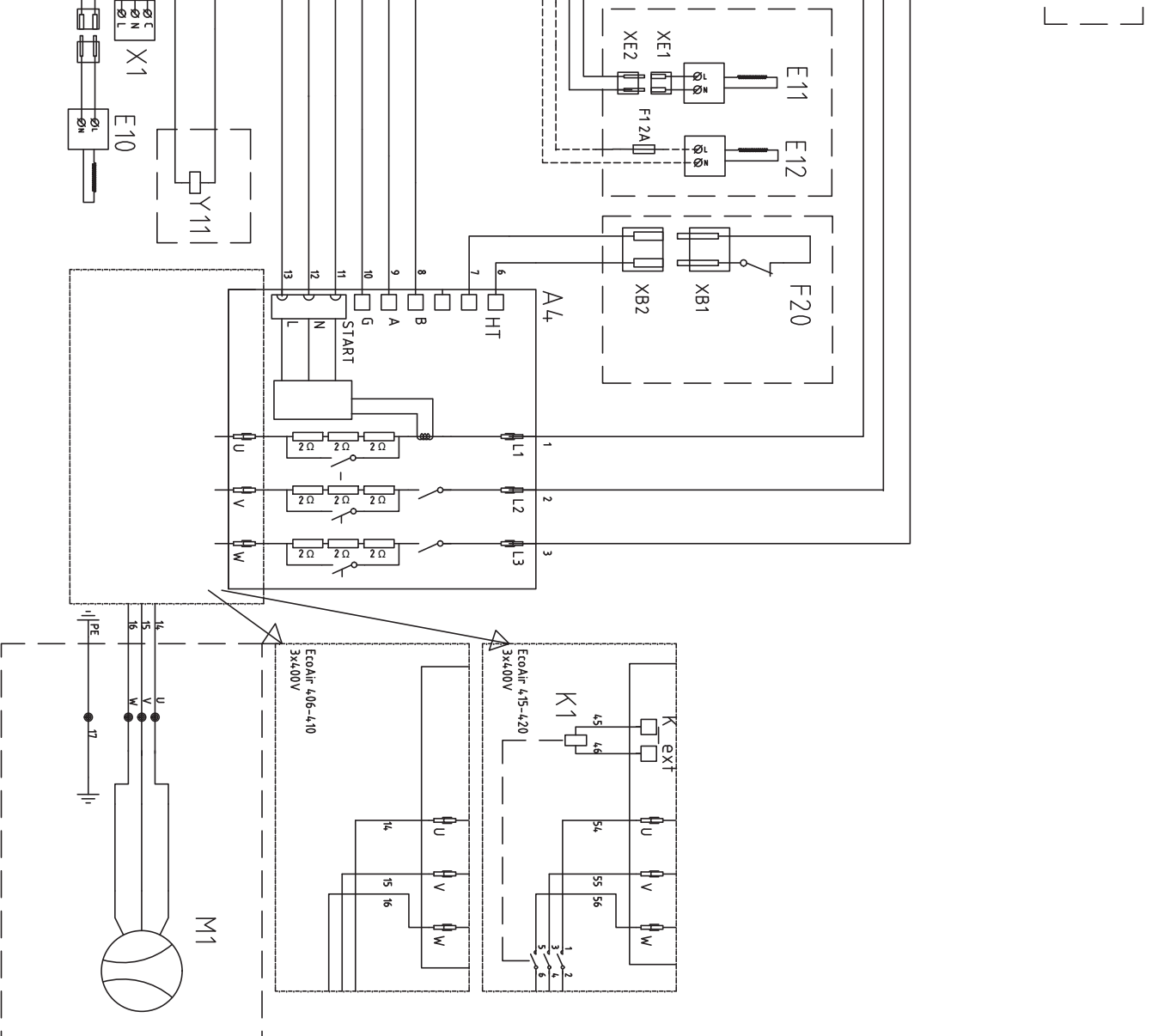

2A)

11)

10.9 Wiring diagram 230V 1N~

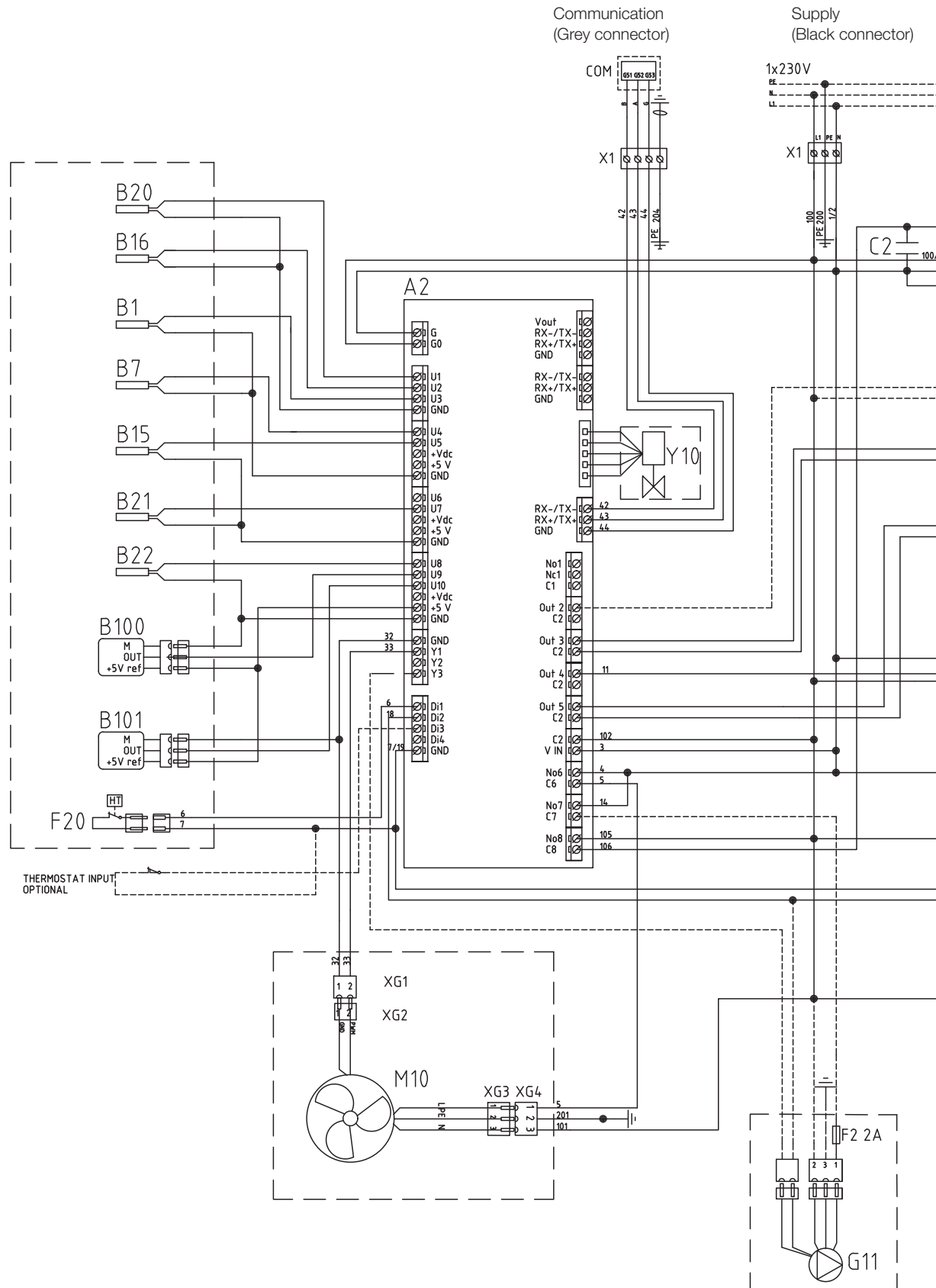

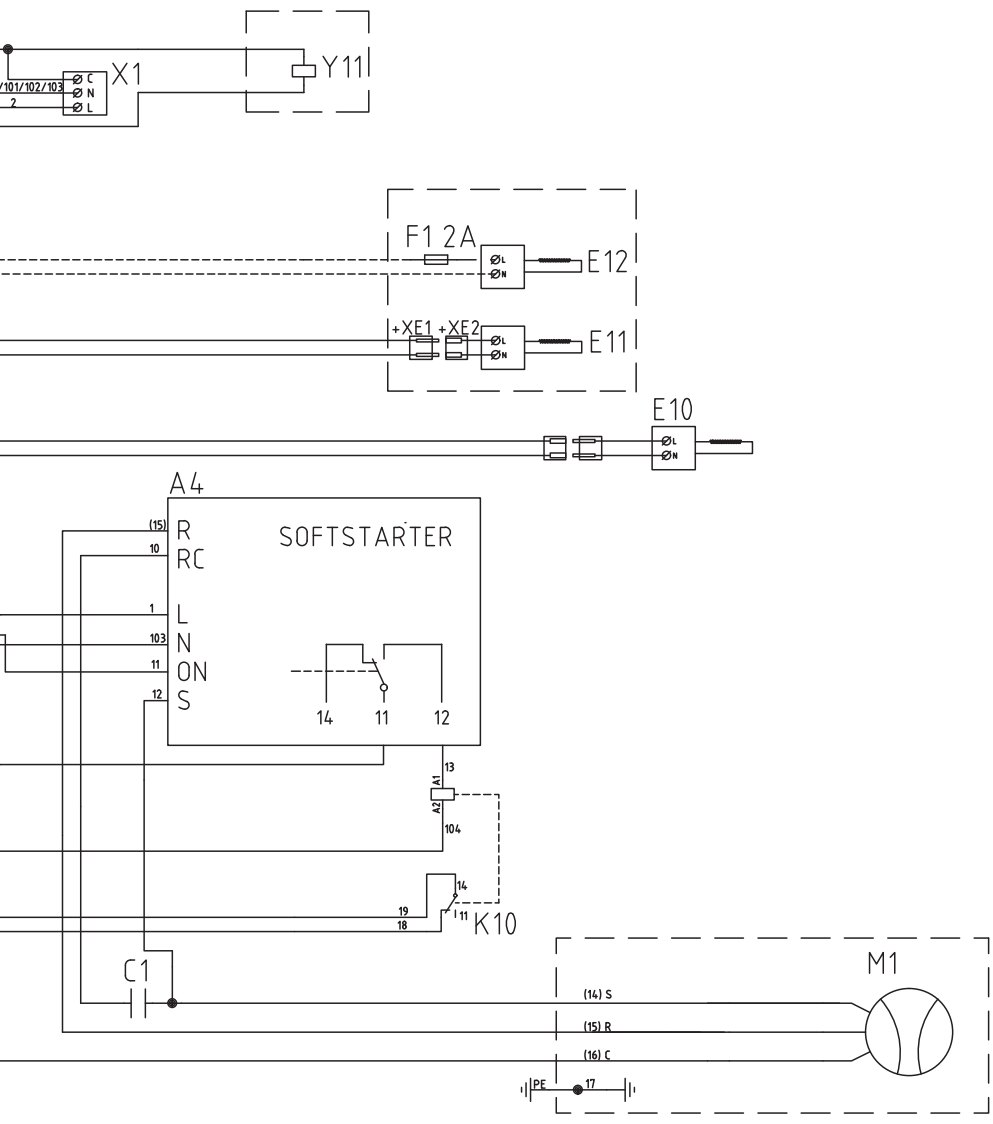

11. First start

1. Check that the boiler and system are full of water and have been bled.
2. Check that all connections are tight.
3. Check that sensors and the charge pump are connected to the power source.
4. Energise the heat pump by switching on the safety switch (the main switch).

Once the system has heated up, check that all connections are tight, the various systems have been bled, heat is coming out into the system and warm water is coming out at the tap locations.

12. Noise data

Standard			
Model	Noise level	Noise pressure 5 m*	Noise pressure 10 m*
EcoAir 406	56 dB(A)	34-37 dB(A)	28-31 dB(A)
EcoAir 408	58 dB(A)	36-39 dB(A)	30-33 dB(A)
EcoAir 410	58 dB(A)	36-39 dB(A)	30-33 dB(A)
EcoAir 415	64 dB(A)	42-45 dB(A)	36-39 dB(A)
EcoAir 420	66 dB(A)	44-47 dB(A)	39-42 dB(A)

Silent mode			
Model	Noise level	Noise pressure 5 m*	Noise pressure 10 m*
EcoAir 415	61 dB(A)	39-42 dB(A)	33-36 dB(A)
EcoAir 420	64 dB(A)	42-45 dB(A)	36-39 dB(A)

* The given noise pressure should be taken as an indication as the level is affected by the surroundings.

The upper value corresponds to 100% reflecting ground and walls (smooth concrete). Values according to EN12102.

Silent mode

The CTC EcoAir 415 and 420 can be set to 'silent mode' by their respective control systems. In this position, the fan runs at a lower speed which means that the product makes less noise.

The stated output will then be reduced by a few percent, depending on the operating situation.

12.1 Sensor data

Temperature °C	Sensor Type 1 NTC kΩ
100	0.22
95	0.25
90	0.28
85	0.32
80	0.37
75	0.42
70	0.49
65	0.57
60	0.7
55	0.8
50	0.9
45	1.1
40	1.3
35	1.5
30	1.8
25	2.2
20	2.6
15	3.2
10	4
5	5
0	6
-5	7
-10	9
-15	12
-20	15
-25	19
-30	25

Temperature °C	Sensor Type 2 NTC kΩ
100	0.67
95	0.78
90	0.908
85	1.06
80	1.25
75	1.47
70	1.74
65	2.07
60	2.5
55	3.0
50	3.6
45	4.4
40	5.3
35	6.5
30	8.1
25	10
20	12.5
15	15.8
10	20
5	26
0	33
-5	43
-10	56
-15	74
-20	99
-25	134
-30	183

Temperature°C	Sensor Type 3 NTC kΩ
130	5.37
125	6.18
120	7.13
115	8.26
110	9.59
105	11.17
100	13.06
95	15.33
90	18.1
85	21.4
80	25.4
75	30.3
70	36.3
65	43.6
60	52.8
55	64.1
50	78.3
45	96.1
40	119
35	147
30	184
25	232
20	293
15	373
10	479
5	619

Temperature °C	NTC 50 kΩ
150	0.89
145	1.00
140	1.14
135	1.29
130	1.47
125	1.67
120	1.91
115	2.19
110	2.5
105	2.9
100	3.4
95	3.9
90	4.6
85	5.4
80	6.3
75	7.4
70	8.8
65	10.4
60	12.5
55	15
50	18
45	22
40	27
35	33
30	40
25	50
20	62
15	78
10	99
5	126

13. Operation and Maintenance

When the installer has installed your new heat pump, you should check together that the system is in perfect operating condition. Let the installer show you where the power switches, controls and fuses are so that you know how the system works and how it should be maintained. Bleed the radiators (depending on type of system) after around three days of operation and top up with water if required.

13.1 Defrosting

The CTC EcoAir 400 is fitted with hot gas defrosting. The heat pump checks constantly whether defrosting is needed and, if so, defrosting starts, the fan stops, the four-way valve changes direction and the hot gas goes to the evaporator instead. A hissing sound is heard as the water drains from the evaporator. When the product has defrosted, the fan starts and the hot gas goes into the condenser instead, and the heat pump returns to normal operation.

13.2 The fan

The fan starts 15 seconds before the condenser and runs until the compressor stops. During defrosting the fan stops and restarts when defrosting is finished.

13.3 Maintenance

A large amount of water passes through the evaporator in the CTC EcoAir 400. Leaves and other debris can get stuck and restrict the air flow. At least once a year the evaporator coil should be checked and cleared of particles that block the air flow. The evaporator and outer covering should be cleaned with a damp cloth or soft brush. No other periodic maintenance or inspection is necessary.

13.4 Periodic maintenance

After three weeks' operation and then every three months during the first year. Then once a year:

- Check that the installation is free of leaks.
- Check that the product and system are free of air; bleed if needed.
- Check that the evaporator is clean.
- No annual leakage control of the refrigerant is required

13.5 Shut-down

The heat pump is shut down using the operating switch. If there is a risk of the water freezing, ensure that there is circulation through the heat pump or drain out all the water from the CTC EcoAir 400.

13.6 Condensation water tray

The condensation tray collects water formed on the CTC EcoAir evaporator during operation and defrosting. The condensation tray is equipped with an electric heating coil which keeps the tray free of ice when it is freezing outside. The condensation tray is located at the bottom on the back of CTC EcoAir 400. By lifting the handle and pulling it out, you can clean and inspect the condensation tray. You can buy a heating cable as an accessory and connect it to the EcoAir 400. The cable is installed in the drain pipe from the condensation tray to a frost-free drain.

14. Troubleshooting/measures

The CTC EcoAir 400 is designed to provide reliable operation and high levels of comfort, and to have a long service life. Various tips are given below which may be helpful and guide you in the event of an operational malfunction.

If a fault occurs, you should always contact the installer who installed your unit. If the installer believes the malfunction is due to a material or design fault, then they will contact CTC-UK to check and rectify the issue. Always provide the product's serial number.

14.1 Air problems

If you hear a rasping sound from the heat pump, check that it is properly bled. Top up with water where required, so that the correct pressure is achieved. If this noise recurs, call a technician to check the cause.

14.2 Alarms

Any alarms and information texts from the CTC EcoAir 400 are displayed in the product which is used to control it; you should therefore consult the manual for that product.

14.3 Circulation and Defrosting

If the circulation between the indoor and the outdoor unit is reduced or stops, the high pressure switch is triggered. Possible reasons for this:

- Defective circulating pump/Circulating pump too small
- Air in the pipes
- Condenser clogged
- Other intermediate obstructions to the water flow

During defrosting the fan stops but the compressor operates and the melted snow and ice flows into the condensation tray under the heat pump. When defrosting stops, the fan starts again and initially a vapour cloud, consisting of damp air which condenses in the cold outdoor air, is created. This is perfectly normal and stops after a few seconds. If the pump heats poorly, check that no unusual ice formation has occurred. Possible reasons for this:

- Defective defrosting automation
- Lack of refrigerant (leakage)
- Extreme weather conditions.

Remember that CTC EcoAir 400 is an air source heat pump which gives less heat power when outdoor temperatures fall, while the heating needs of the house increase. When temperatures fall quickly, this means that you may experience a lack of heating power.

